

Vivado Design Suite Tutorial

Model-Based DSP Design Using System Generator

UG948 (v2015.3) October 26, 2015



Revision History

The following table shows the revision history for this document.

Date	Version	Changes
10/26/2015	2015.3	Recaptured screen displays throughout manual to reflect changes to GUI or changes in results displayed. In Lab 8: Step 3: Create a Design in IPI , modified procedure and directory names to describe how Lab 8 works within the 2015.3 Vivado release.
08/14/2015	2015.2	No technical updates. Re-release only.
08/14/2015	2015.1	Tutorial has been completely rewritten for 2015.1 release.

Table of Contents

Revision History	2
System Generator for DSP Overview.....	5
Introduction.....	5
Software Requirements.....	7
Configuring MATLAB to the Vivado® Design Suite	7
Locating and Preparing the Tutorial Design Files	8
Lab 1: Introduction to System Generator.....	9
Introduction.....	9
Step 1: Creating a Design in an FPGA	10
Step 2: Creating an Optimized Design in an FPGA	25
Step 3: Creating a Design Using Discrete Resources	28
Summary.....	38
Lab 2: Working with Data Types.....	40
Introduction.....	40
Step 1: Designing with Floating-Point Data Types.....	41
Step 2: Designing with Fixed-Point Data Types	45
Summary.....	53
Lab 3: Working with Multi-Rate Systems	54
Introduction.....	54
Step 1: Creating Clock Domain Hierarchies.....	54
Step 2: Creating Asynchronous Channels.....	58
Step 3: Specifying Clock Domains.....	63
Summary.....	68
Lab 4: Working with Workspace Variables.....	69
Introduction.....	69
Step 1: Using Workspace Variables	70
Summary.....	75

Lab 5: Modeling Control with M-Code	76
Introduction.....	76
Step 1: Designing Padding Logic.....	76
Summary.....	80
Lab 6: Modeling Blocks with HDL	81
Lab 6 Introduction	81
Step 1: Import RTL as a Black Box.....	81
Summary.....	87
Lab 7: Modeling Blocks with C Code.....	88
Lab 7 Introduction	88
Step 1: Creating a System Generator Package from Vivado HLS	89
Step 2: Including a Vivado HLS Package in a System Generator Design.....	92
Summary.....	96
Lab 8: Using AXI Interfaces and IP Integrator.....	97
Introduction.....	97
Step 1: Review the AXI Interfaces	98
Step 2: Create a Vivado Project using System Generator IP	99
Step 3: Create a Design in IPI.....	101
Step 4: Implement the Design	108
Summary.....	109
Lab 9: Using a System Generator Design with a Zynq-7000 AP SoC	110
Introduction.....	110
Step 1: Review the AXI4-Lite Interface Drivers.....	111
Step 2: Developing Software and Running it on the ZYNQ-7000 System	114
Summary.....	120
Legal Notices.....	121
Please Read: Important Legal Notices.....	121

System Generator for DSP Overview

Introduction

System Generator for DSP is a design tool in the Vivado® Design Suite that enables you to use the MathWorks® model-based Simulink® design environment for FPGA design. Previous experience with Xilinx® FPGA devices or RTL design methodologies is not required when using System Generator. Designs are captured in the Simulink™ modeling environment using a Xilinx-specific block set. Downstream FPGA steps including RTL synthesis and implementation (where the gate level design is placed and routed in the FPGA) are automatically performed to produce an FPGA programming bitstream.

Over 80 building blocks are included in the Xilinx-specific DSP block set for Simulink. These blocks include common building blocks such as adders, multipliers and registers. Also included are complex DSP building blocks such as forward-error-correction blocks, FFTs, filters, and memories. These complex blocks leverage Xilinx LogiCORE™ IP to produce optimized results for the selected target device.



VIDEO: The [Vivado Design Suite Quick Take Video Tutorial: System Generator Multiple Clock Domains](#) describes how to use Multiple Clock Domains within System Generator, making it possible to implement complex DSP systems.



VIDEO: The [Vivado Design Suite QuickTake Video Tutorial: Generating Vivado HLS block for use in System Generator for DSP](#) describes how to generate a Vivado HLS IP block for use in System Generator, and ends with a summary of how the Vivado HLS block can be used in your System Generator design.



VIDEO: The [Vivado Design Suite Quick Take Video: Using Vivado HLS C/C++/System C block in System Generator](#) describes how to incorporate your Vivado HLS design as an IP block into System Generator for DSP.



VIDEO: The [Vivado Design Suite Quick Take Video: Specifying AXI4-Lite Interfaces for your Vivado System Generator Design](#) describes how System Generator provides AXI4-Lite abstraction making it possible to incorporate a DSP design into an embedded system. Full support includes integration into the IP Catalog, interface connectivity automation, and software APIs.



VIDEO: The [Vivado Design Suite QuickTake Video Tutorial: Using Hardware Co-Simulation with Vivado System Generator for DSP](#) describes how to use Point-to-Point Ethernet Hardware Co-Simulation with Vivado System Generator for DSP. Hardware co-simulation makes it possible to incorporate a design running in an FPGA directly into a Simulink simulation.

In this tutorial, you will do the following:

- Lab 1: Understand how to create and validate a model using System Generator, synthesize the model into FPGA hardware, and then create a more optimal hardware version of the design.
- Lab 2: Learn how fixed-point data types can be used to trade off accuracy against hardware area and performance.
- Lab 3: Learn how to create an efficient design using multiple clock domains.
- Lab 4: Make use of workspace variables to easily parameterize your models.
- Lab 5: Model a control system using M-code.
- Lab 6: Learn how to incorporate existing RTL designs, written in Verilog or VHDL, into your design.
- Lab 7: Import C/C++ source files into a System Generator model by leveraging the tool integration with Vivado High-Level Synthesis (HLS).
- Lab 8: Use AXI interfaces and Vivado IP integrator to easily include your model into a larger design.
- Lab 9: Integrate your design into a larger system and operate the design under CPU control.

Software Requirements

The lab exercises in this tutorial require the installation of MATLAB **R2015b**, R2015a, R2014b, or R2014.a.

See the *Vivado Design Suite User Guide: Release Notes, Installation, and Licensing* ([UG973](#)) for a complete list and description of the system and software requirements.

Configuring MATLAB to the Vivado® Design Suite

Before you begin, you should verify that MATLAB is configured to the Vivado Design Suite. Do the following:

1. Configure MATLAB.
 - On Windows systems:
 - a. Select **Start > All Programs > Xilinx Design Tools > Vivado 2015.3 > System Generator > System Generator 2015.3 MATLAB Configurator**.



IMPORTANT: On Windows systems you may need to launch the MATLAB configurator as Administrator. When **MATLAB Configurator** is selected in the menu, use the mouse right-click to select **Run as Administrator**.

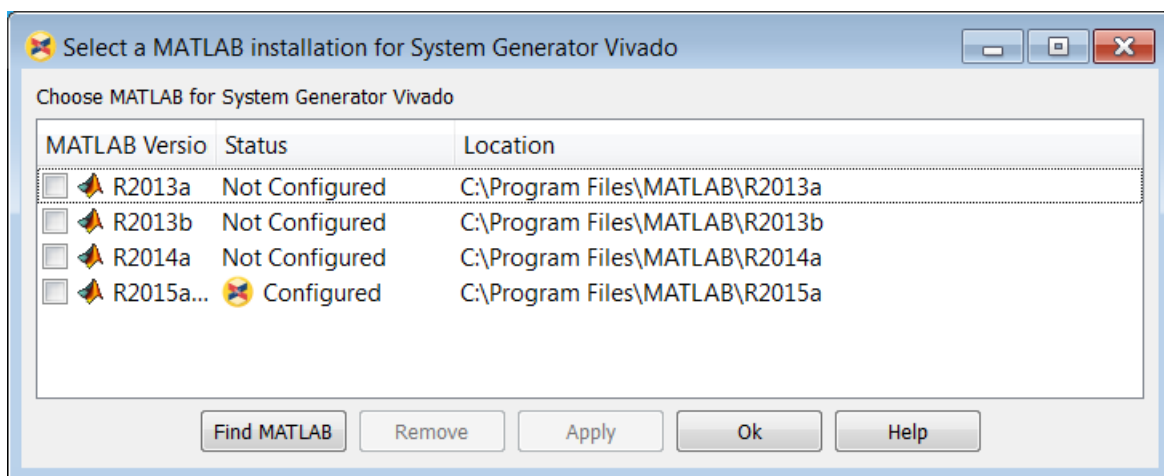

Figure 1: Select MATLAB Installation

- b. Click the check box of the version of MATLAB you want to configure and then click **OK**.
- On Linux systems:

Launching System Generator under Linux is handled via a shell script called `sysgen` located in the `<Vivado install dir>/bin` directory. Before launching this script, you must make sure the

MATLAB executable can be found in your Linux system's \$PATH environment variable. When you execute the `sysgen` script, it will launch the first MATLAB executable found in \$PATH and attach System Generator to that session of MATLAB. Also, the `sysgen` shell script supports all the options that MATLAB supports and can be passed as command line arguments to the `sysgen` script.

When the System Generator opens, you can confirm the version of MATLAB to which System Generator is attached by entering the `version` command in the MATLAB Command Window.

```
>> version

ans =

8.5.0.197613 (R2015a)
```

Locating and Preparing the Tutorial Design Files

There are separate project files and sources for each of the labs in this tutorial. You can find the design files for this tutorial under [Vivado Design Suite - 2015.3 Tutorials](http://www.xilinx.com/Vivado_Design_Suite_-_2015.3_Tutorials) on the www.xilinx.com website.

1. **Download** the [Reference Design Files](#) (`ug948-design-files.zip`) from the Xilinx website.
2. **Extract** the zip file contents into any write-accessible location on your hard drive or network location.



RECOMMENDED: *You will modify the tutorial design data while working through this tutorial. You should use a new copy of the `SysGen_Tutorial` directory extracted from `ug948-design-files.zip` each time you start this tutorial.*



TIP: *This document assumes the tutorial files are stored at `C:\SysGen_Tutorial`. All pathnames and figures in this document refer to this pathname. If you choose to store the tutorial in another location, adjust the pathnames accordingly.*

Lab 1: Introduction to System Generator

Introduction

In this lab exercise, you will learn how use System Generator to specify a design in Simulink and synthesize the design into an FPGA. This tutorial uses a standard FIR filter and demonstrates how System Generator provides you the design options that allow you to control the fidelity of the final FPGA hardware.

Objectives

After completing this lab, you will be able to:

- Capture your design using the System Generator Blocksets.
- Capture your designs in either complex or discrete Blocksets.
- Synthesize your designs in an FPGA using the Vivado Design Environment.

Procedure

This lab has three primary parts:

- In Step 1, you will review an existing Simulink design using the Xilinx FIR Compiler block, and review the final gate level results in Vivado.
- In Step 2, over-sampling is used to create a more efficient design.
- In Step 3, the same filter is designed using standard discrete blockset parts.

Step 1: Creating a Design in an FPGA

In this step you learn the basic operation of System Generator and how to synthesize a Simulink design into an FPGA.

1. Invoke System Generator.
 - On Windows systems select **Start > All Programs > Xilinx Design Tools > Vivado 2015.3 > System Generator > System Generator 2015.3.**
 - On Linux Systems, type `sysgen` at the command prompt.
2. Navigate to the Lab1 folder: `cd C:\SysGen_Tutorial\Lab1.`

You can view the directory contents in the MATLAB Current Folder window, or type `ls` at the command line prompt.

3. At the Matlab command prompt, type `open Lab1_1.slx`

The Lab1_1 design opens, showing two sine wave sources being added together and passed separately through two low-pass filters. This design highlights that a low-pass filter may be implemented using the Simulink **FDATool** or **Lowpass Filter** blocks.

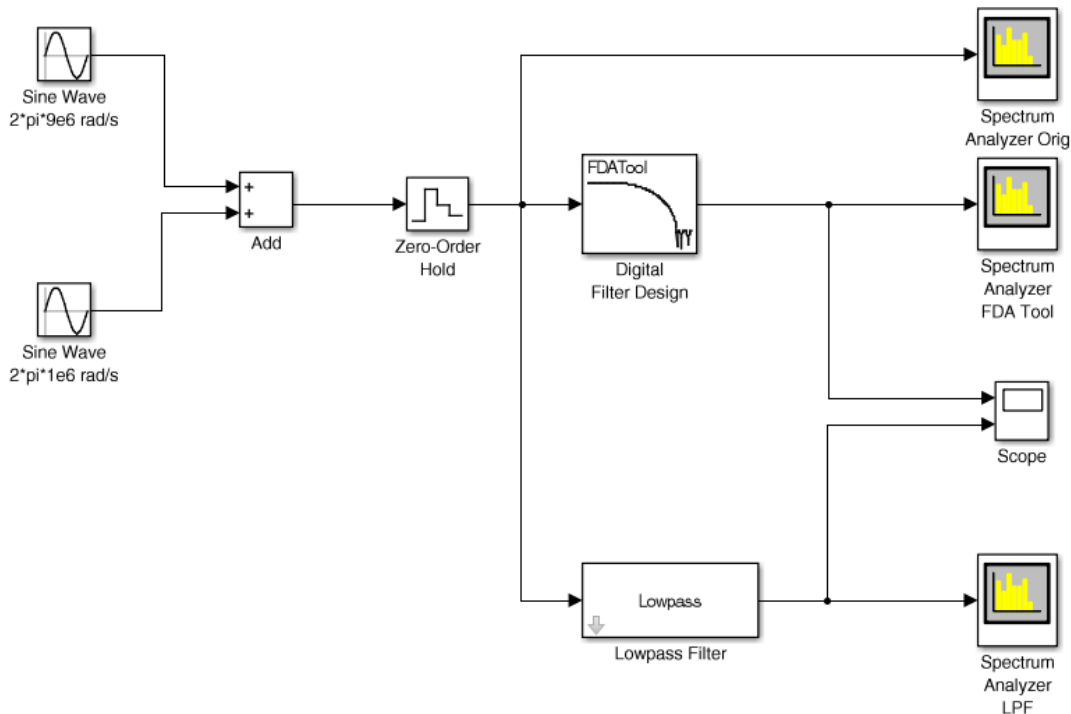

Figure 2: Introduction Step 1 Design

- From your Simulink project worksheet, select **Simulation > Run** or click the **Run** simulation button.

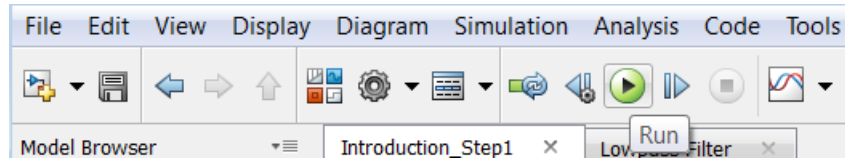

Figure 3: Run Simulation Button

When simulation completes you can see the spectrum for the initial summed waveforms, showing a 1 MHz and 9 MHz component, and the results of both filters showing the attenuation of the 9 MHz signals.

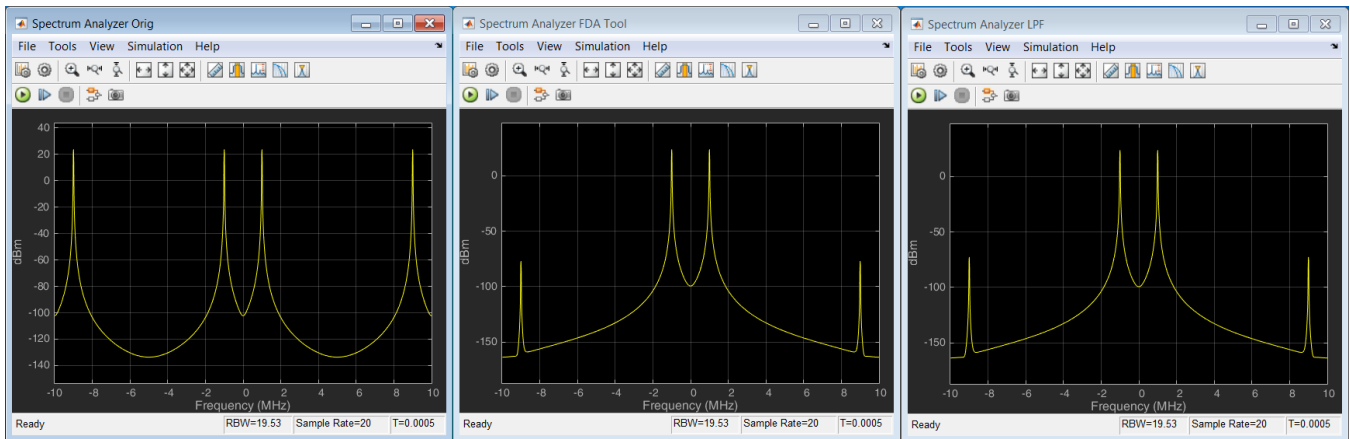

Figure 4: Initial Results

You will now create a version of this same filter using System Generator blocks for implementation in an FPGA.

- Type `simulink` at the MATLAB command prompt, or click the **Library Browser** button in the Simulink toolbar to open the Simulink Library Browser.

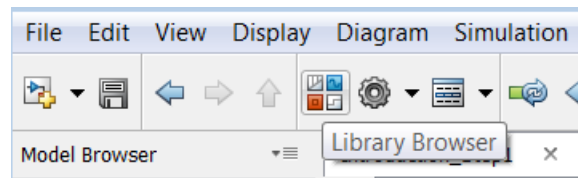

Figure 5: Simulink Library Browser

When using System Generator, the Simulink library includes specific blocks for implementing designs in an FPGA. You can find a complete description of the blocks provided by System Generator in the *Vivado Design Suite Reference Guide: Model-Based DSP Design Using System Generator (UG958)*.

6. Expand the **Xilinx Blockset** menu, select **DSP**, then select **FIR Compiler 7.2**.
7. Right-click the **FIR Compiler 7.2** block and select **Add block to model Lab1_1**.

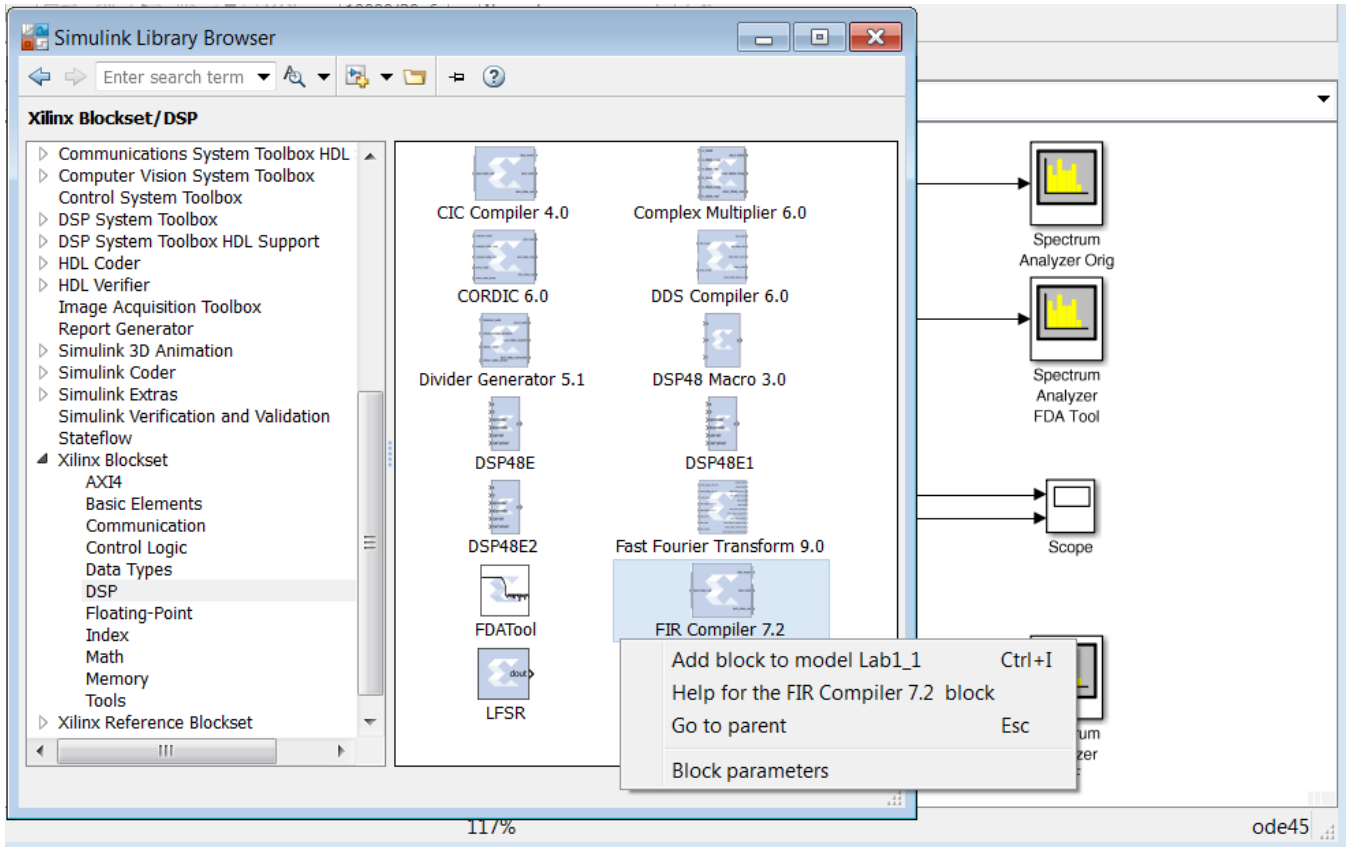

Figure 6: Add FIR Compiler Block

You can define the filter coefficients for the FIR Compiler block by accessing the block attributes – double-click the **FIR Compiler 7.2** block to view these – or, as in this case, they may be defined using the **FDATool**.

8. In the same DSP blockset as the previous step, select **FDATool** and add it to the Lab1_1 design.
- An FPGA design requires three important aspects to be defined:
- The input ports
 - The output ports
 - The FPGA technology

The next three steps show how each of these attributes is added to your Simulink design.



IMPORTANT: *If you fail to correctly add these components to your design, it cannot be implemented in an FPGA. Subsequent labs will review in detail how these blocks are configured; however, they must be present in all System Generator designs.*

- In the Basic Elements menu, select **Gateway In** and add it to the design.

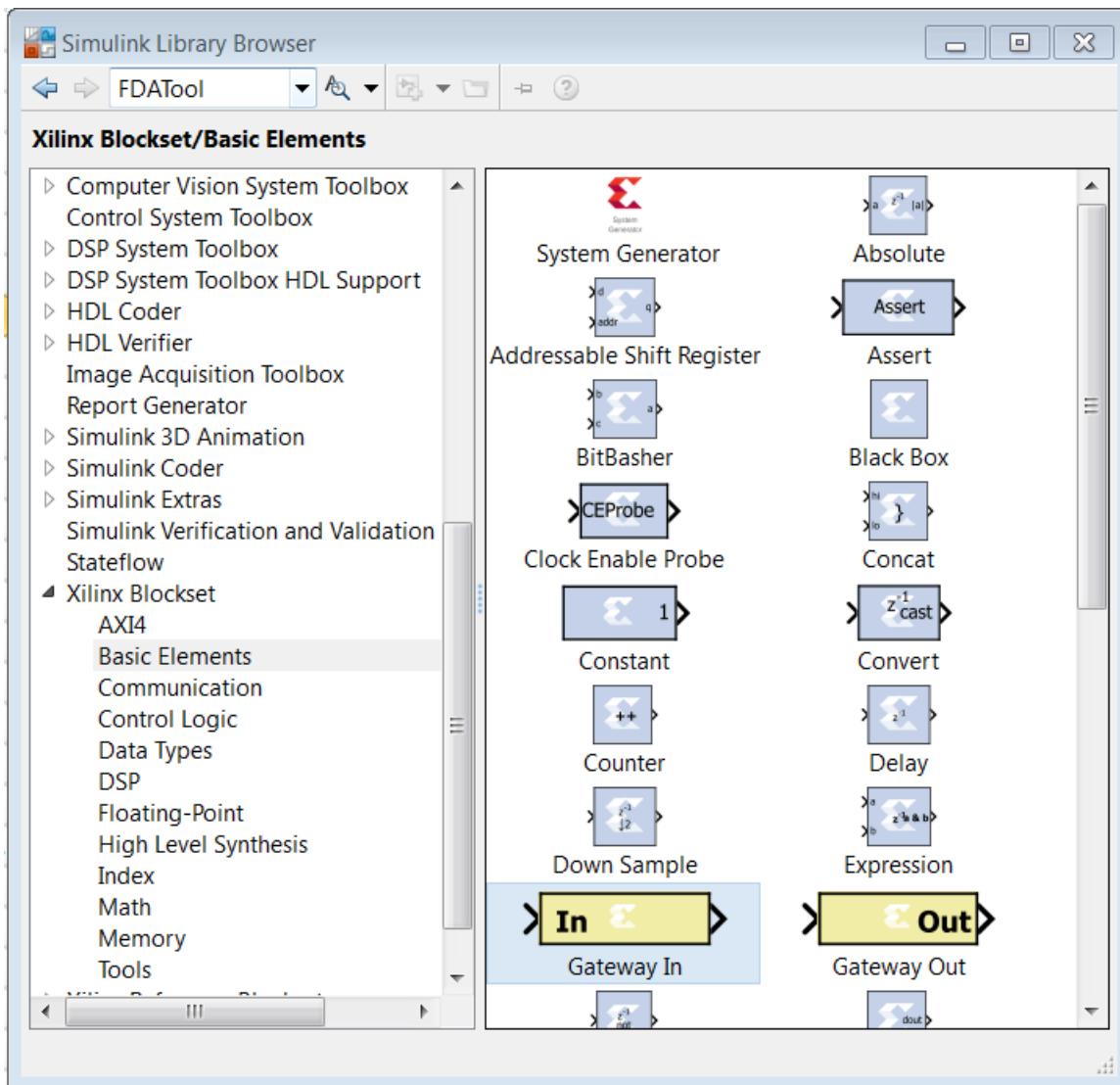

Figure 7: Adding a Gateway In

- Similarly, from the same menu add a **Gateway Out** block to the design.
- Similarly, from the same menu add the **System Generator** token used to define the FPGA technology.

- Finally, make a copy of one of the existing Spectrum Analyzer blocks and rename the instance to Spectrum Analyzer SysGen by clicking the instance name label and editing the text.
- Connect the blocks as shown in the following figure. Use the left-mouse key to make connections between ports and nets.

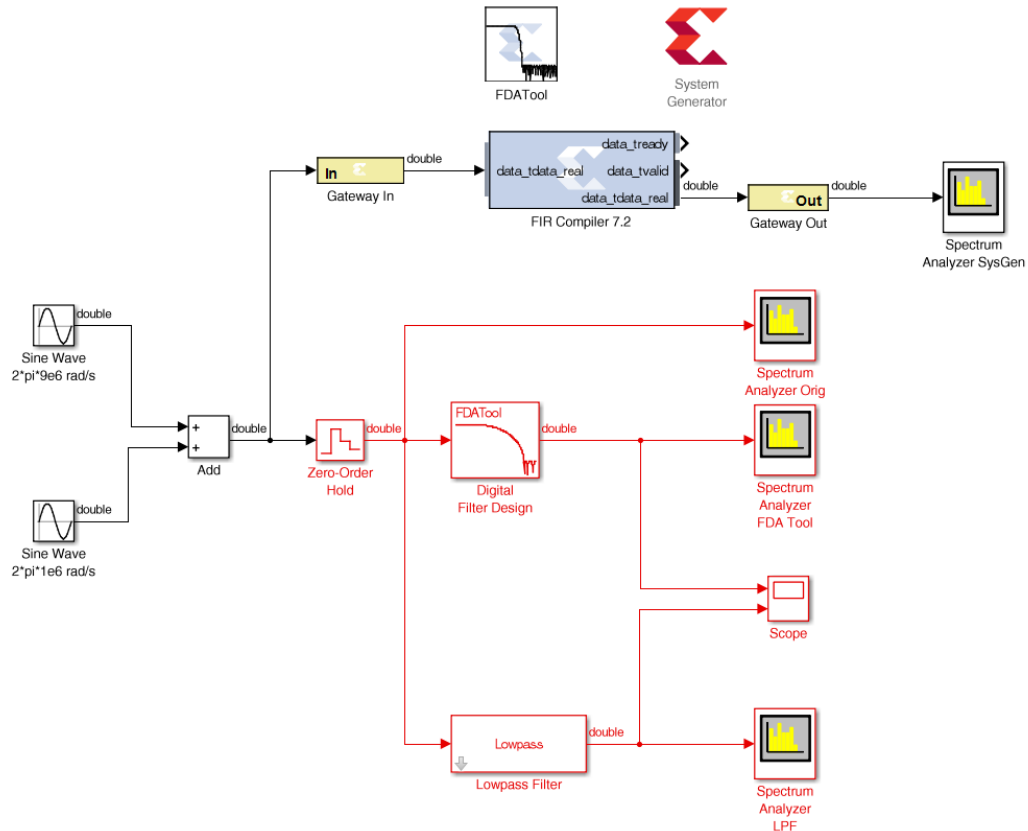

Figure 8: Initial System Generator Design

The next part of the design process is to configure the System Generator blocks.

Configure the System Generator Blocks

The first task is to define the coefficients of the new filter. For this task you will use the Xilinx block version of FDATool. If you open the existing FDATool block, you can review the existing Frequency and Magnitude specifications.

- Double-click the **Digital Filter Design** instance to open the Properties Editor.
This allows you to review the properties of the existing filter.

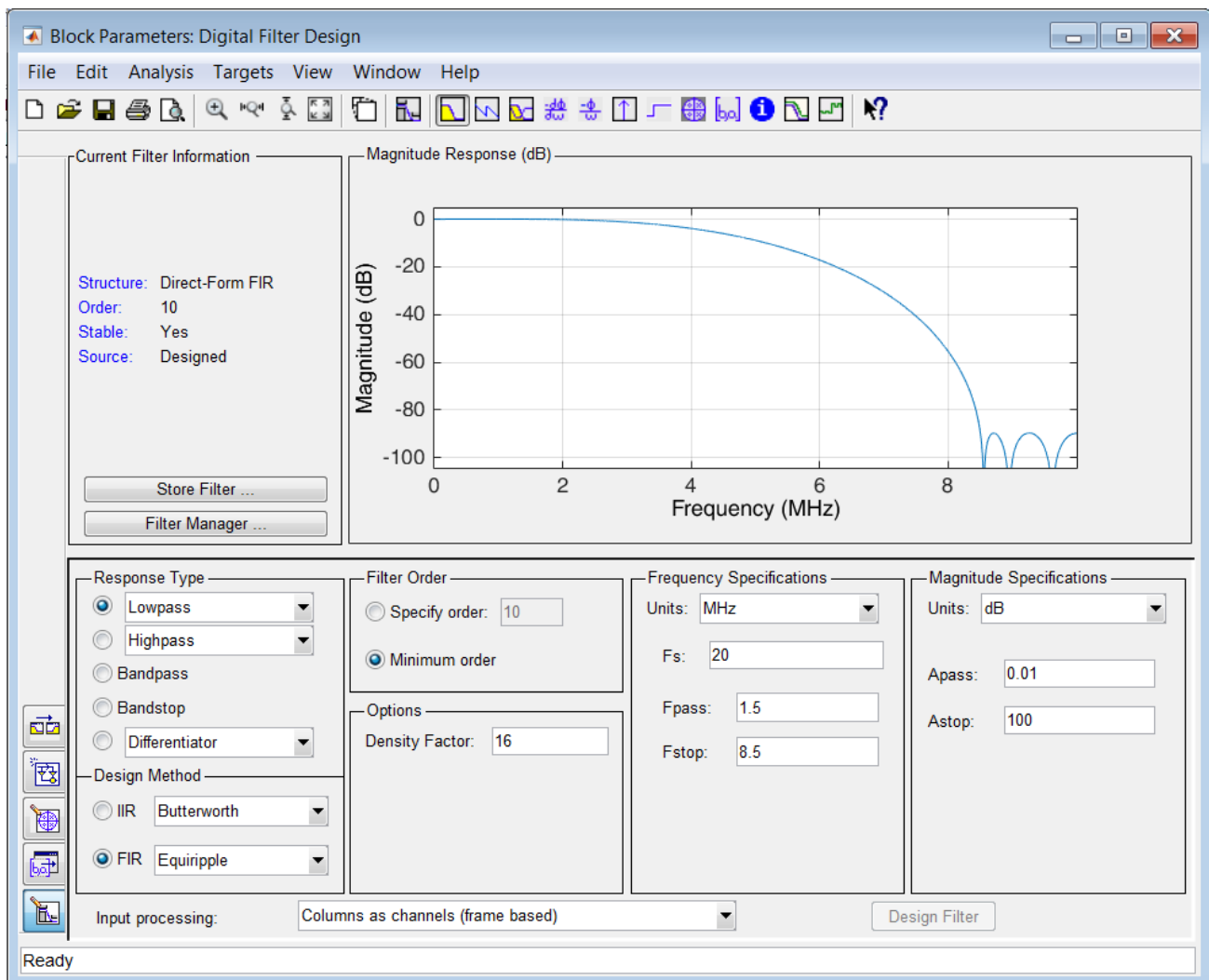

Figure 9: Filter Specifications

2. Close the Properties Editor for the **Digital Filter Design** instance.
3. Double-click the **FDATool** instance to open the Properties Editor.
4. Adjust the filter specifications to the following values (shown in the figure above):
 - **Frequency Specifications**
 - **Units** = MHz
 - **Fs** = 20
 - **Fpass** = 1.5
 - **Fstop** = 8.5

- **Magnitude Specifications**

- **Units** = dB
- **Apass** = 0.01
- **Astop** = 100

5. Click the **Design Filter** button.

6. Close the Properties Editor.

Now, associate the filter parameters of the **FDATool** instance with the **FIR Compiler 7.2** instance.

7. Double-click the **FIR Compiler 7.2** instance to open the Properties Editor.

8. In the **Filter Specification** tab, replace the existing coefficients (**Coefficient Vector**) with `xlfda_numerator('FDATool')` to use the coefficients defined by the **FDATool** instance.

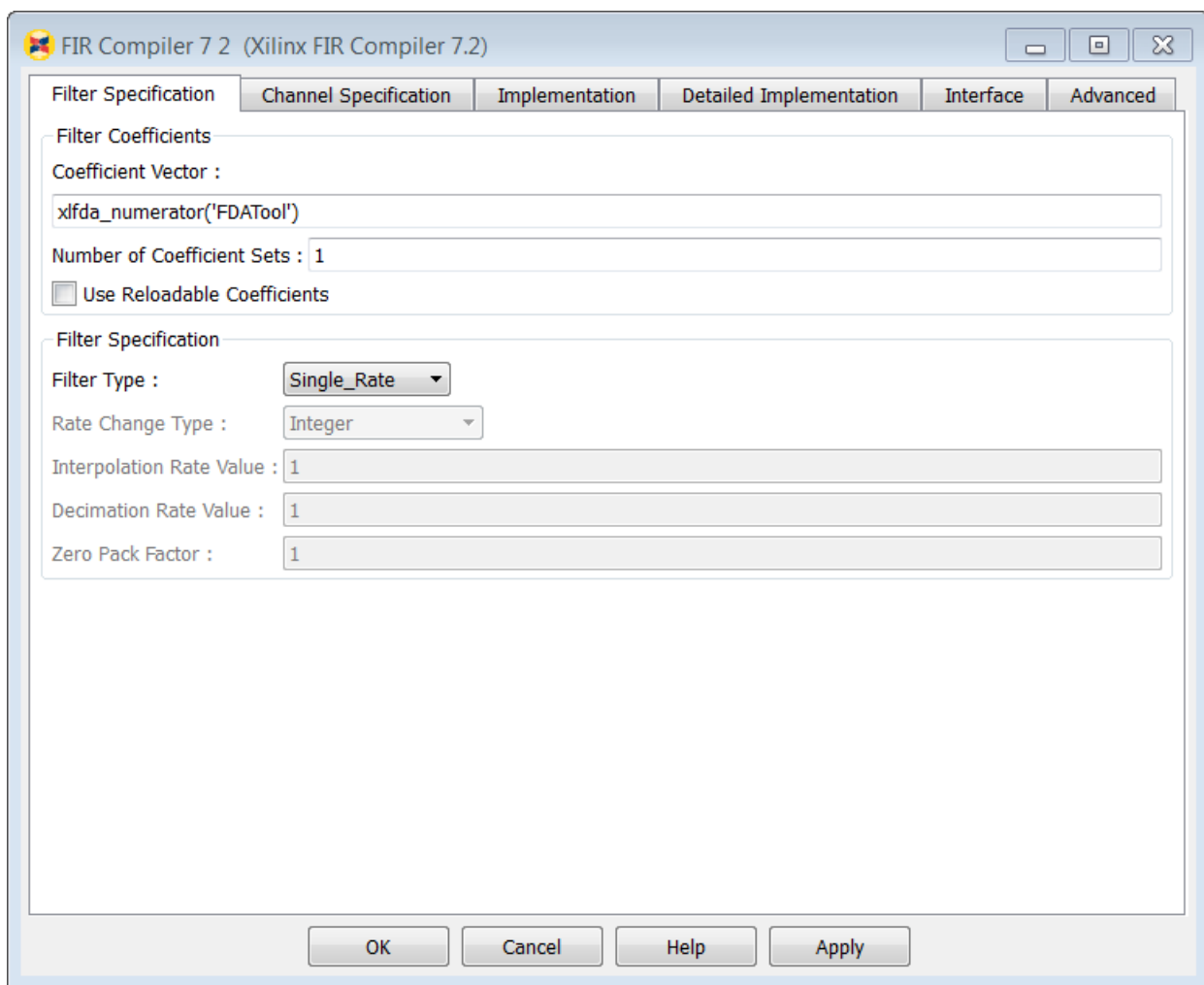

Figure 10: FIR Compiler 7.2 Specifications

9. In the **Implementation** tab of the Properties Editor, use the **Quantization** drop-down menu to select **Maximize_Dynamic_Range**.
10. Click **OK** to exit the FIR Compiler Properties Editor.

In an FPGA, the design operates at a specific clock rate and using a specific number of bits to represent the data values.

The transition between the continuous time used in the standard Simulink environment and the discrete time of the FPGA hardware environment is determined by defining the sample rate of the **Gateway In** blocks. This determines how often the continuous input waveform is sampled. This sample rate is automatically propagated to other blocks in the design by System Generator. In a similar manner, the number of bits used to represent the data is defined in the **Gateway In** block and also propagated through the system.

Although not used in this tutorial, some Xilinx blocks enable rate changes and bit-width changes, up or down, as part of this automatic propagation. More details on these blocks are found in the *Vivado Design Suite Reference Guide: Model-Based DSP Design Using System Generator* ([UG958](#)).

Both of these attributes (rate and bit width) determine the degree of accuracy with which the continuous time signal is represented. Both of these attributes also have an impact on the size, performance, and hence cost of the final hardware.

System Generator allows you to use the Simulink environment to define, simulate, and review the impact of these attributes.

11. Double-click the **Gateway In** block to open the Properties Editor.

Because the highest frequency sine wave in the design is 9 MHz, sampling theory dictates the sampling frequency of the input port must be at least 18 MHz. For this design, you will use 20 MHz.

12. At the bottom of the Properties Editor, set the **Sample Period** to **1/20e6**.
13. For now, leave the bit width as the default 16-bit 2's complement with 14-bits representing the data below the binary point. This allows us to express a range of -2.0 to 1.999, which exceeds the range required for the summation of the sine waves (both of amplitude 1).

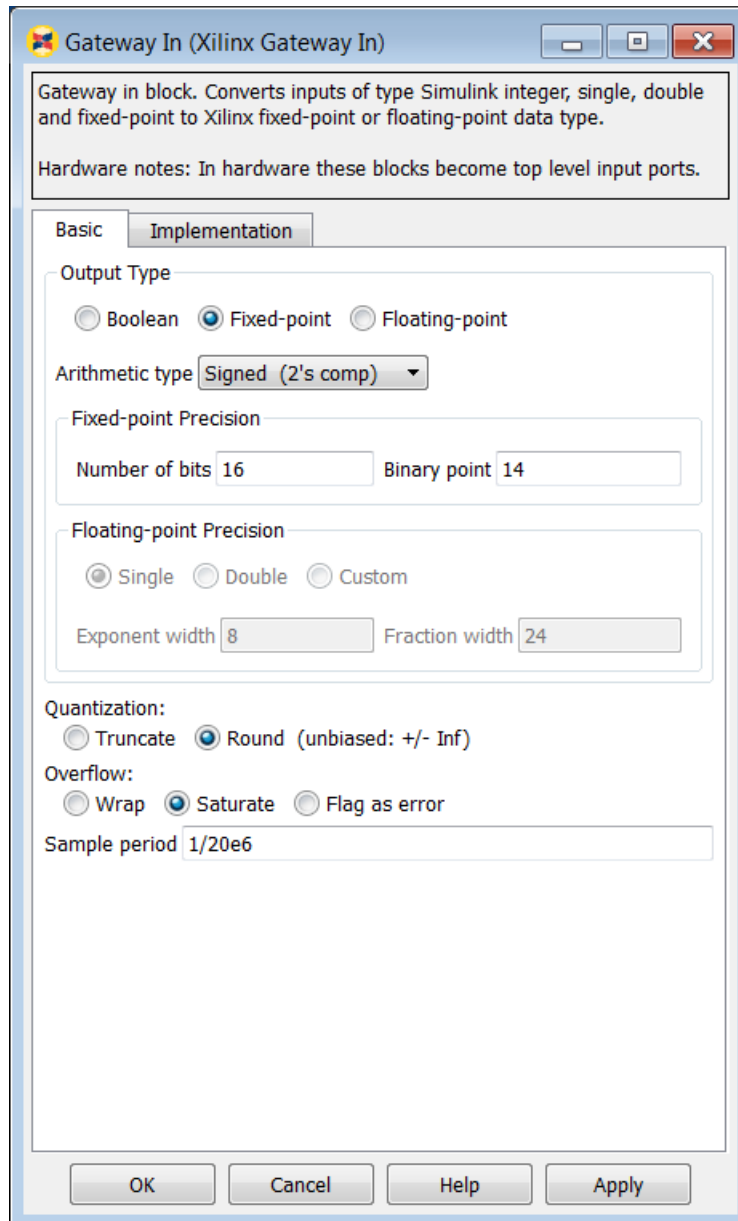

Figure 11: Gateway In Properties

14. Click **OK** to close the **Gateway In** Properties Editor.

This now allows us to use accurate sample rate and bit-widths to accurately verify the hardware.

15. Double-click the **System Generator** token to open the Properties Editor.

Because the input port is sampled at 20 MHz to adequately represent the data, you must define the clock rate of the FPGA and the Simulink sample period to be at least 20 MHz.

16. Select the **Clocking** tab.
 - a. Specify an **FPGA clock Period** of 50 ns (1/20 MHz).
 - b. Specify a **Simulink system period** of 1/20e6 seconds.

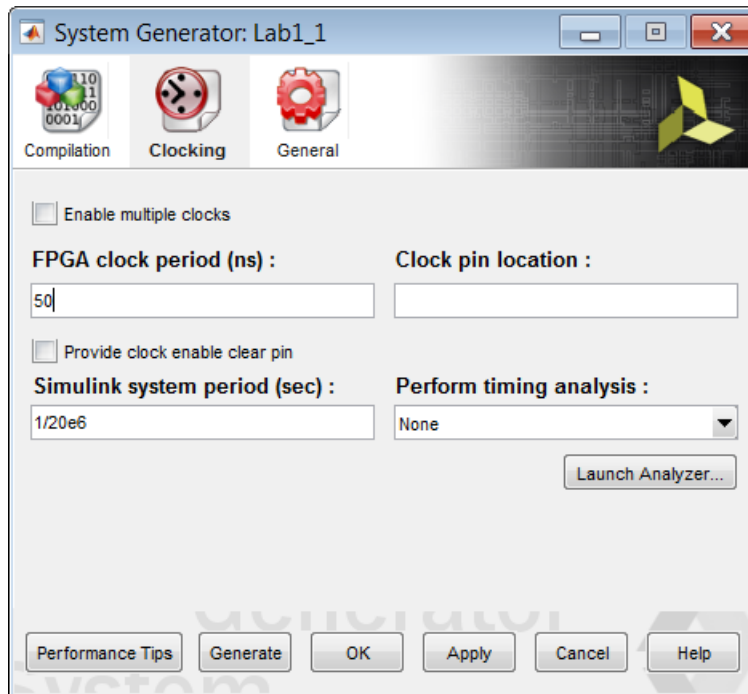



Figure 12: Lab1_1 Clocking

17. Click **OK** to exit the **System Generator** token.
18. Click the **Run** simulation button  to simulate the design and view the results, as shown in [Figure 13: FIR Compiler Results](#).

Because the new design is cycle and bit accurate, simulation may take longer to complete than before.

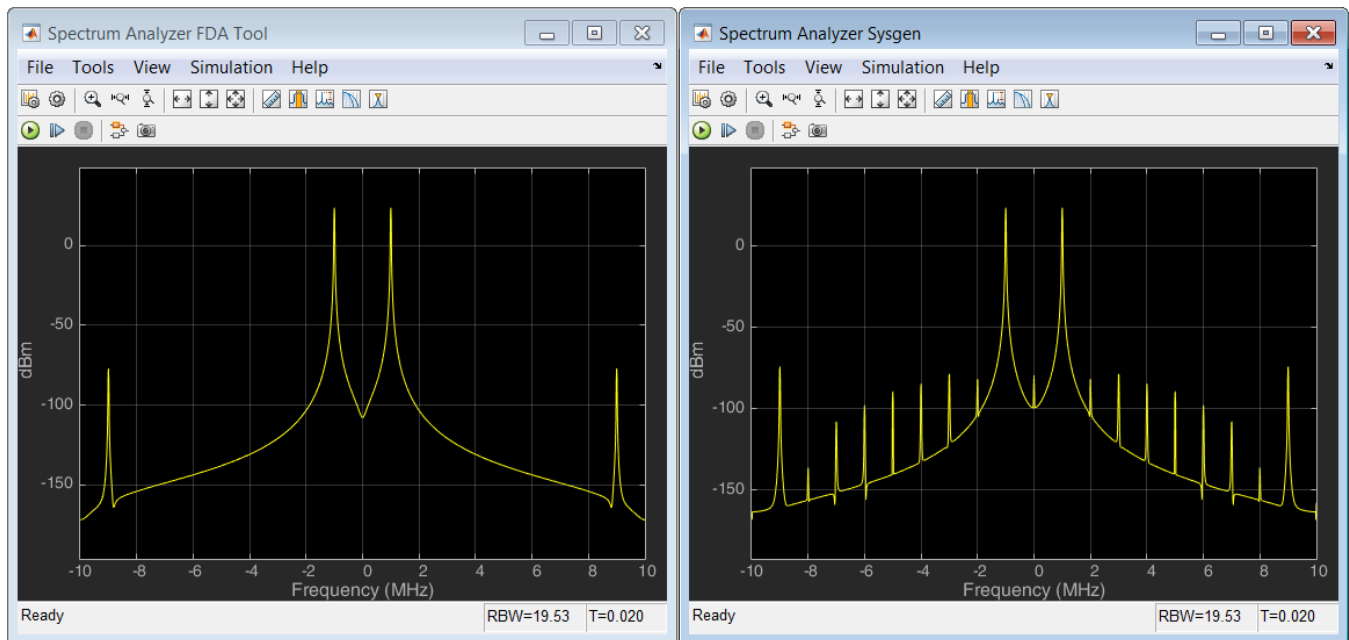

Figure 13: FIR Compiler Results

The results are shown above, on the right hand side (in the Spectrum Analyzer SysGen window), and differ slightly from the original design (shown on the left in the Spectrum Analyzer FDA Tool window). This is due to the quantization and sampling effect inherent when a continuous time system is described in discrete time hardware.

The final step is to implement this design in hardware. This process will synthesize everything contained between the Gateway In and Gateway Out blocks into a hardware description. This description of the design is output in the Verilog or VHDL Hardware Description Language (HDL). This process is controlled by the **System Generator** token.

19. Double-click the **System Generator** token to open the Properties Editor.
20. Select the **Compilation** tab to specify details on the device and design flow.
21. From the **Compilation** menu, select the IP Catalog compilation target to ensure the output is in IP Catalog format. The **Part** menu selects the FPGA device. For now, use the default device. Also, use the default hardware description language, VHDL.

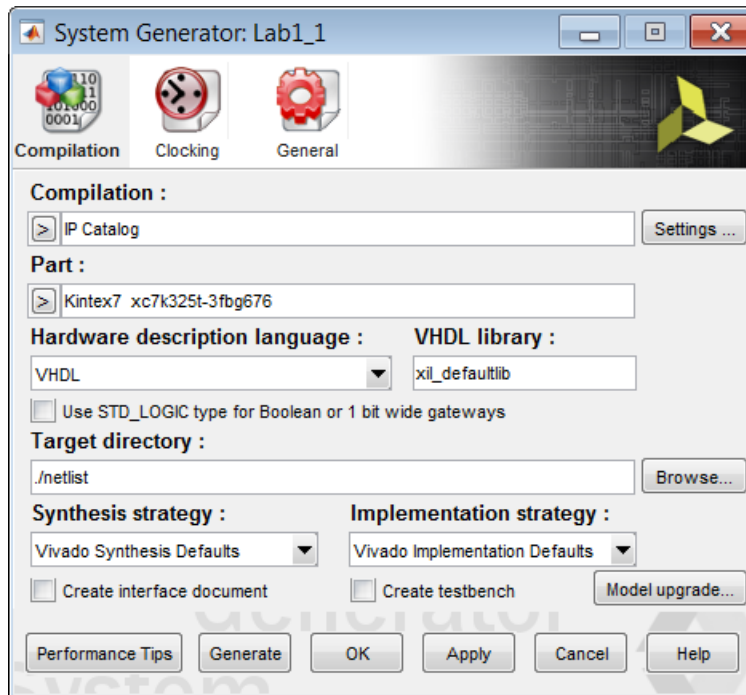

Figure 14: System Generator Token for Lab 1 Step 1

22. Click **Generate** to compile the design into hardware.

The compilation process transforms the design captured in Simulink blocks into an industry standard RTL (Register Transfer Level) design description. The RTL design can be synthesized into a hardware design. The Compilation status dialog box appears when the hardware design description has been generated.

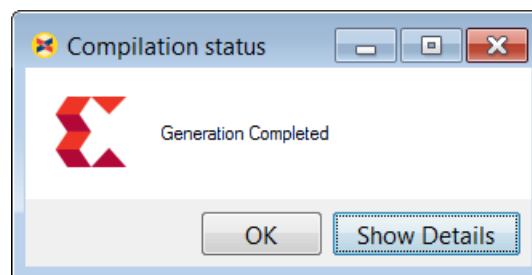

Figure 15: Generation Complete

23. Click **OK** to dismiss the Compilation status dialog box.

24. Click **OK** to dismiss the **System Generator** token.

The final step in the design process is to create the hardware and review the results.

Create the Hardware and Review the Results

The output from design compilation process is written to the `netlist` directory. This directory contains three subdirectories:

- **sysgen:** This contains the RTL design description written in the industry standard VHDL format. This is provided for users experienced in hardware design who wish to view the detailed results.
- **ip:** This directory contains the design IP, captured in Xilinx IP Catalog format, which is used to transfer the design into the Xilinx Vivado Design Suite. [Lab 8: Using AXI Interfaces and IP Integrator](#), presented later in this document, explains in detail how to transfer your design IP into the Vivado Design Suite for implementation in an FPGA.
- **ip_catalog:** This directory contains an example Vivado project with the design IP already included. This project is provided only as a means of quick analysis.

You will now review the results in hardware by using the example Vivado project in the **ip_catalog** directory.



IMPORTANT: *The Vivado project provided in the `ip_catalog` directory does not contain top-level I/O buffers. The results of synthesis provide a very good estimate of the final design results; however, the results from this project cannot be used to create the final FPGA.*

25. Invoke the Vivado Design Suite: **Start > All Programs > Xilinx Design Tools > Vivado 2015.3 > Vivado 2015.3**
26. Click **Open Project** and then navigate to the folder
C:\SysGen_Tutorial\Lab1\netlist\ip_catalog.
27. Select file `lab1_1.xpr` and the Vivado IDE invokes the generated project file.
28. Click the **Run Synthesis** button to synthesize the design into hardware.

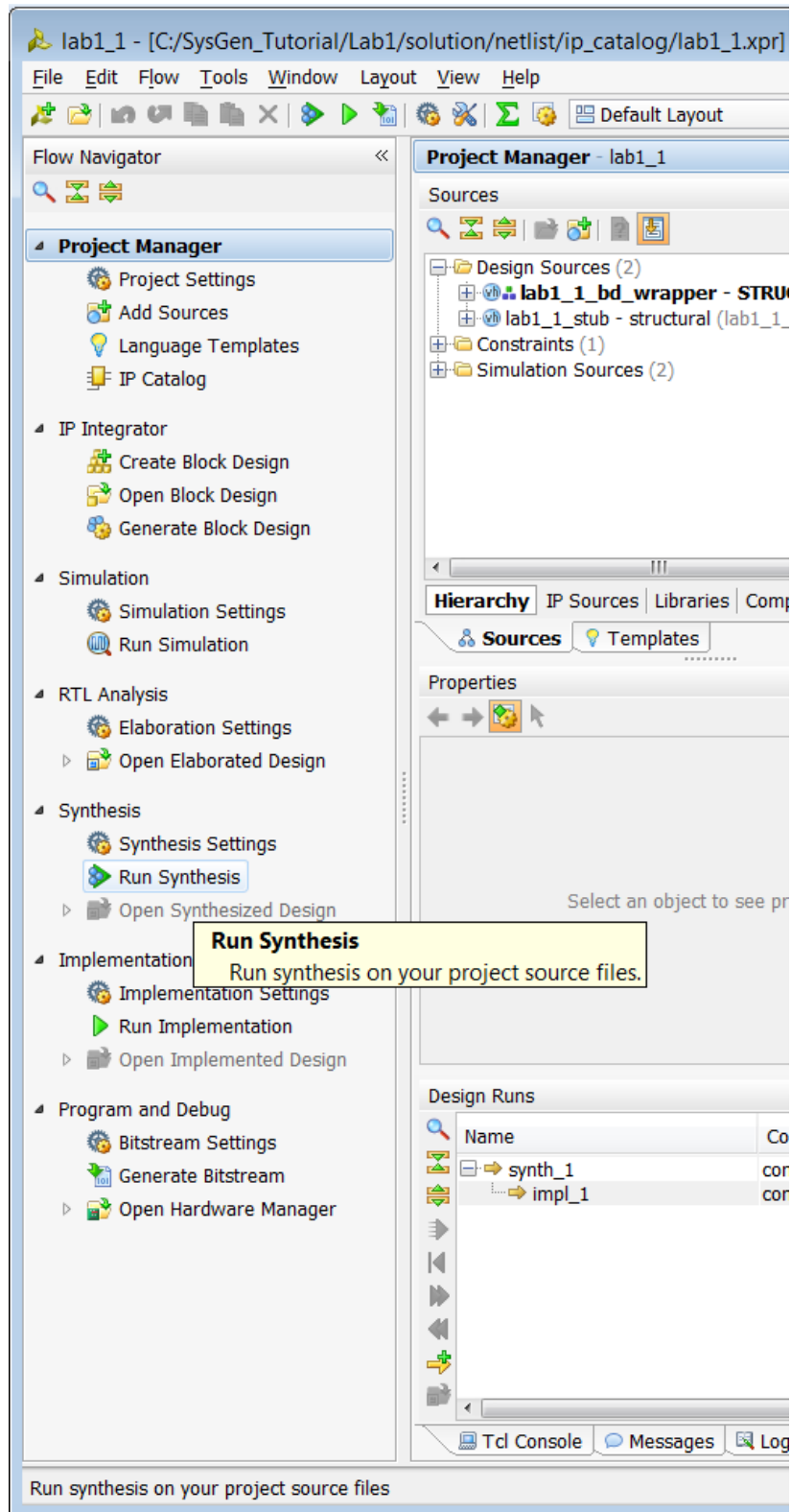

Figure 16: Vivado Project for Design Lab1_1

To get an exact confirmation of the final resources and timing, you could select **Run Implementation** when the synthesis finishes. However, the results after synthesis provide a very good approximation of the final results without the additional run time of implementing a fully placed and routed design and is recommended early in the design cycle.

29. When synthesis completes, select **View Reports** from the Synthesis Completed dialog box and click **OK**.

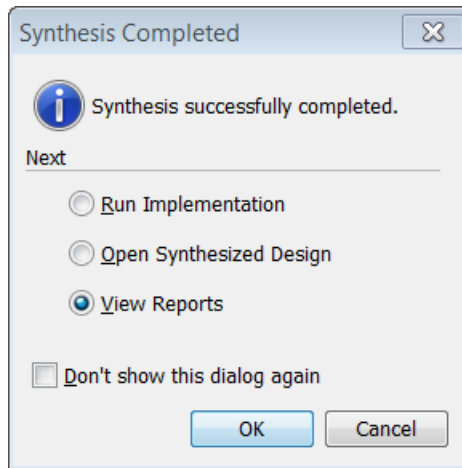

Figure 17: Synthesis Complete Dialog Box

30. In the Utilization section of the Project Summary, click the **Table** tab to view a summary of the resources used after the design is synthesized.

Resource	Estimation	Available	Utilization %
LUT	168	203800	0.08
LUTRAM	161	64000	0.25
FF	298	407600	0.07
DSP	6	840	0.71
IO	50	400	12.50
BUFG	1	32	3.12

Graph **Table**

Figure 18: Lab1_1 Synthesis Results

31. Exit the Vivado Design Suite.

32. Exit the Lab1_1.slx Simulink worksheet.

Step 2: Creating an Optimized Design in an FPGA

In this step you will see how an FPGA can be used to create a more optimized version of the same design used in Step 1, by oversampling.

1. At the command prompt, type `open Lab1_2.slx`.
2. From your Simulink project worksheet, select **Simulation > Run** or click the **Run** simulation button  to confirm this is the same design used in [Step 1: Creating a Design in an FPGA](#).
3. Double-click the **System Generator** token to open the Properties Editor.

As noted in Step 1, the design requires a minimum sample frequency of 18 MHz and it is currently set to 20 MHz (a 50 ns **FPGA clock period**).

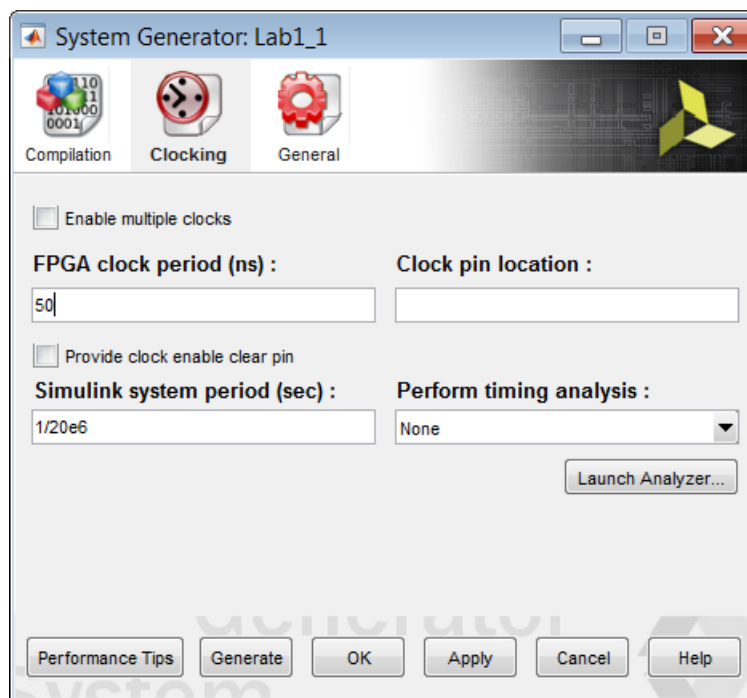

Figure 19: Initial Lab1_2 Clocking

The frequency at which an FPGA device can be clocked easily exceeds 20 MHz. Running the FPGA at a much higher clock frequency will allow us to use the same hardware resources to compute multiple intermediate results.

4. Double-click the **FDATool** instance to open the Properties Editor.

5. Click the **Filter Coefficients** button  to view the filter coefficients.

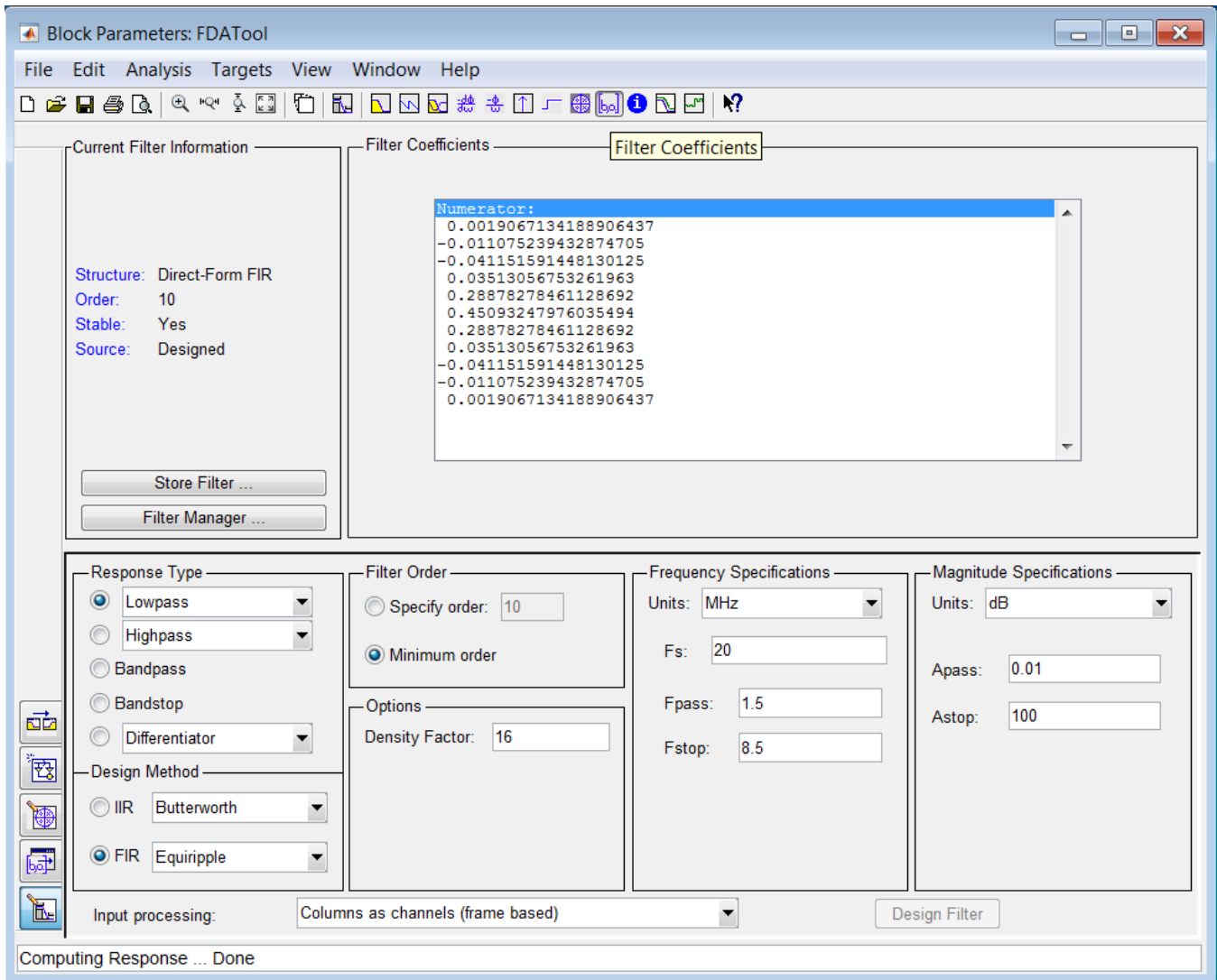

Figure 20: Lab1_2 Filter Coefficients

This shows the filter uses 11 symmetrical coefficients. This will require a minimum of 6 multiplications. This is indeed what is shown in [Figure 18: Lab1_1 Synthesis Results](#), where the final hardware is using 6 DSP48 components, the FPGA resource used to perform a multiplication.

The current design samples the input at a rate of 20 MHz. If the input is sampled at 6 times the current frequency, it is possible to perform all calculations using a single multiplier.

6. Close the **FDATool** Properties Editor.

7. In the **System Generator** token update the sampling frequency to 120 MHz (6 * 20 MHz) in this way:
 - a. Specify an **FPGA clock Period** of 8.33 ns (1/120 MHz).
 - b. Specify a **Simulink system period** of 1/120e6 seconds.

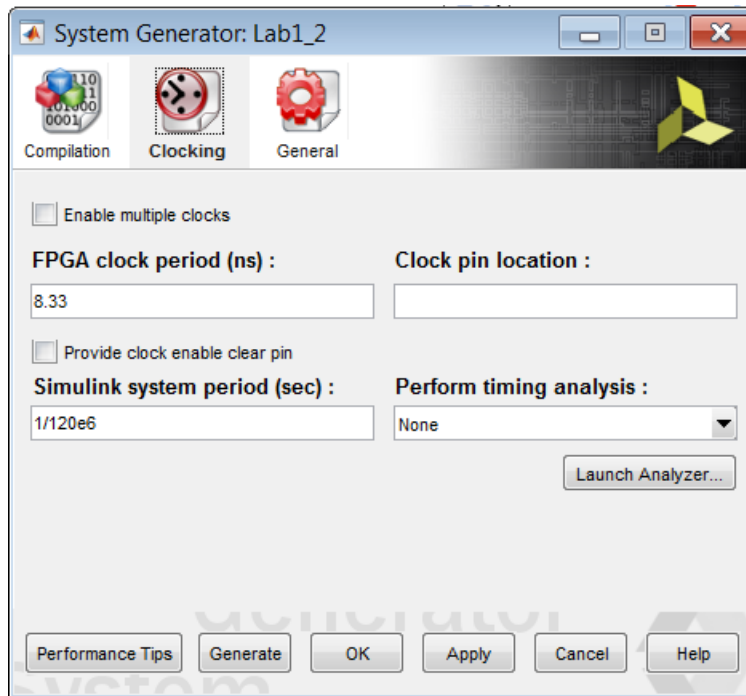

Figure 21: Lab1_2 Clocking

8. Press **Generate** to compile the design into a hardware description.
9. When generation completes, click **OK** to dismiss the Compilation status dialog box.
10. Click **OK** to dismiss the **System Generator** token.
11. Use one of these two alternatives to open the example Vivado project:
 - Use **Start > All Programs > Xilinx Design Tools > Vivado 2015.3 > Vivado 2015.3**, then click **Open Project**, navigate to the folder C:\SysGen_Tutorial\Lab1\netlist\ip_catalog and select the file lab1_2.xpr.
 OR
 - Navigate to C:\SysGen_Tutorial\Lab1\netlist\ip_catalog and double-click the file lab1_2.xpr.
12. In the Flow Navigator, click the **Run Synthesis** button to synthesize the design into hardware.
13. When synthesis completes, select **View Reports** from the Synthesis Completed dialog box and click **OK**.

14. In the Utilization section of the Project Summary, click the **Table** tab to view a summary of the resources used to synthesize the design.

Resource	Estimation	Available	Utilization %
LUT	86	203800	0.04
LUTRAM	54	64000	0.08
FF	186	407600	0.05
DSP	1	840	0.12
IO	50	400	12.50
BUFG	1	32	3.12

Graph **Table**

Post-Synthesis Post-Implementation

Figure 22: Lab1_2 Synthesis Results

The hardware design now uses only a single DSP48 resource (a single multiplier) and compared to the results in [Figure 18: Lab1_1 Synthesis Results](#), the resources used are approximately half.

15. Exit the Vivado Design Suite.
16. Exit the Lab1_2.slx Simulink worksheet.

Step 3: Creating a Design Using Discrete Resources

In this step you will see how System Generator can be used to build a design using discrete components to realize a very efficient hardware design.

1. At the command prompt, type `open Lab1_3.slx`.

This opens the Simulink design shown in the following figure. This design is similar to the one in the previous two steps. However, this time the filter is designed with discrete components and is only partially complete. As part of this step, you will complete this design and learn how to add and configure discrete parts.

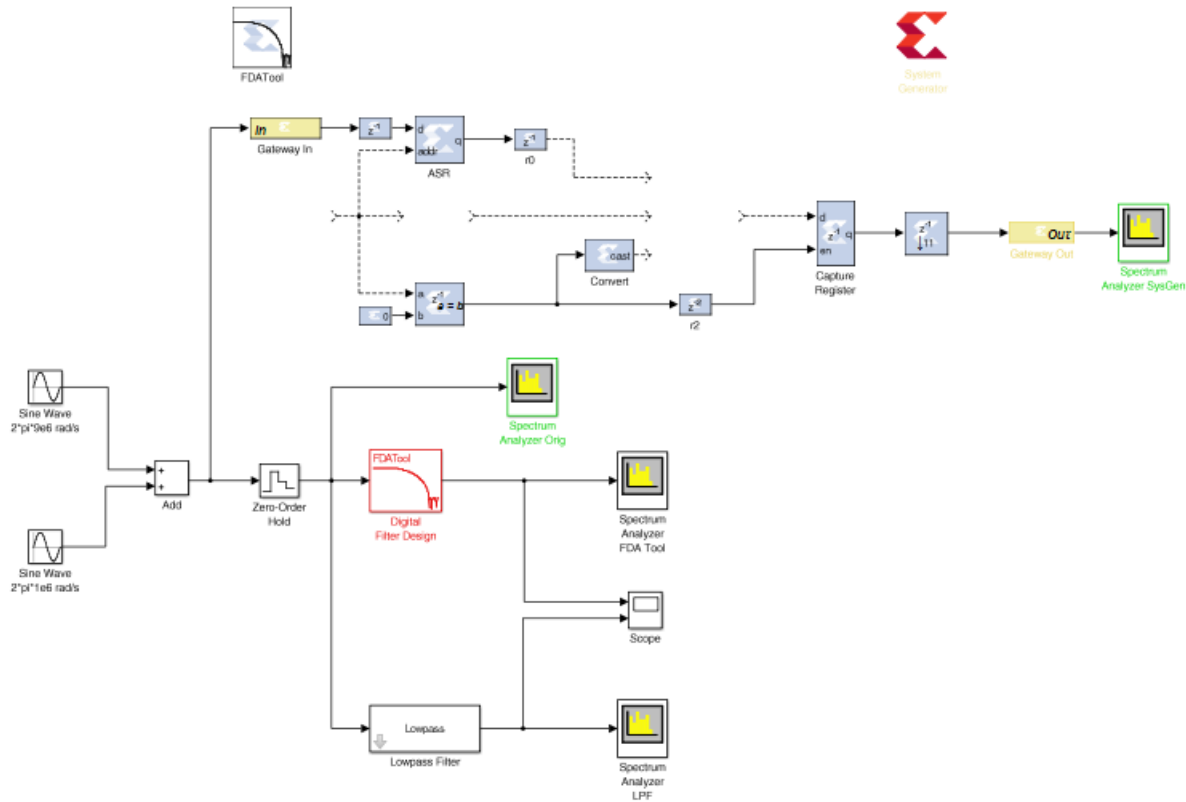



Figure 23: Initial Lab1_3 Design

This discrete filter operates in this way:

- Samples arrive through port In and after a delay are stored in a shift register (instance **ASR**).
- A ROM is required for the filter coefficients.
- A counter is required to select both the data and coefficient samples for calculation.
- A multiply accumulate unit is required to perform the calculations.
- The final down-sample unit selects an output every n th cycle.

Start by adding the discrete components to the design.

2. Click the **Library Browser** button  in the Simulink toolbar to open the Simulink Library Browser.
3. Expand the **Xilinx Blockset** menu.
 - a. As shown in the following figure, select the **Control Logic** section, then select the **Counter** and right-click with the mouse to add this component to the design.

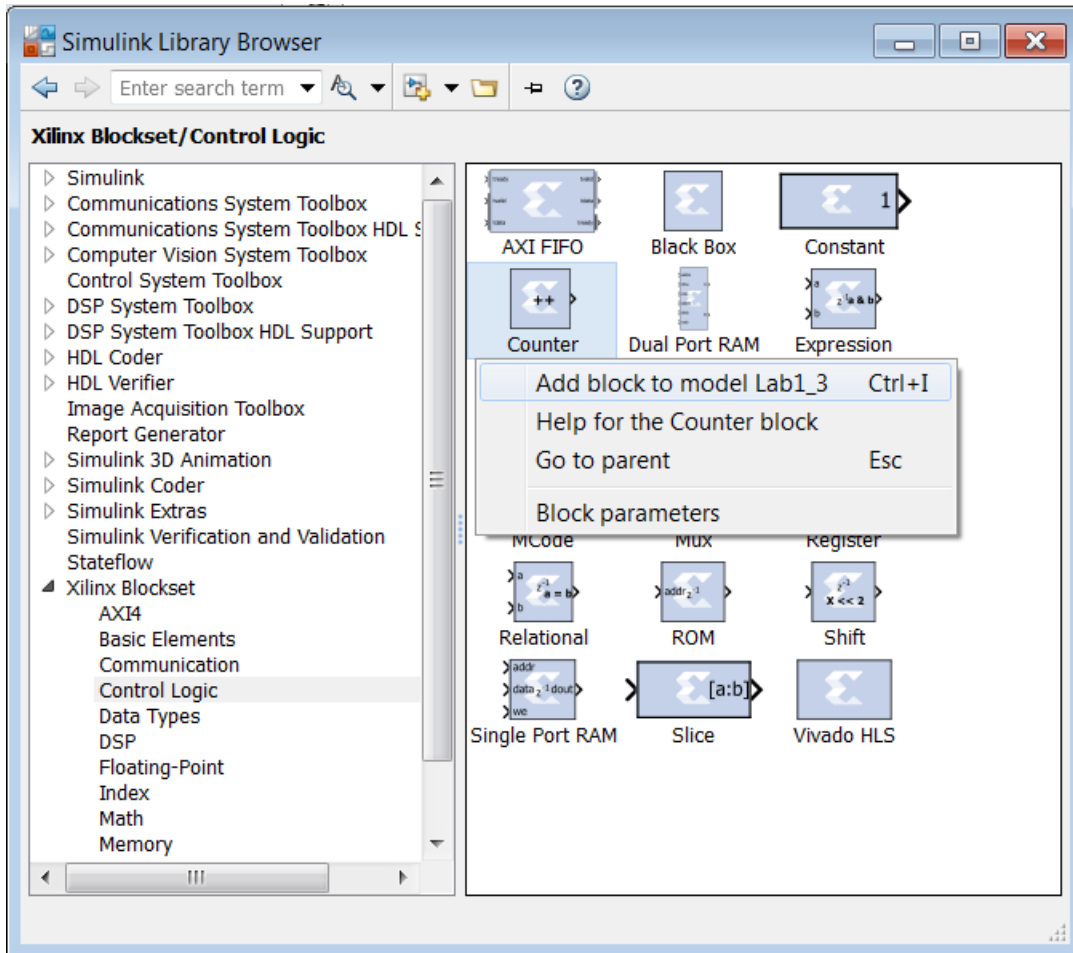

Figure 24: Lab3_1 Counter Instance

- b. Select the **Memory** section (shown at the bottom left in the figure above) and add a **ROM** to the design.
- c. Finally, select the **DSP** section and add a **DSP48 Macro 3.0** to the design.
4. Connect the three new instances to the rest of the design as shown below.

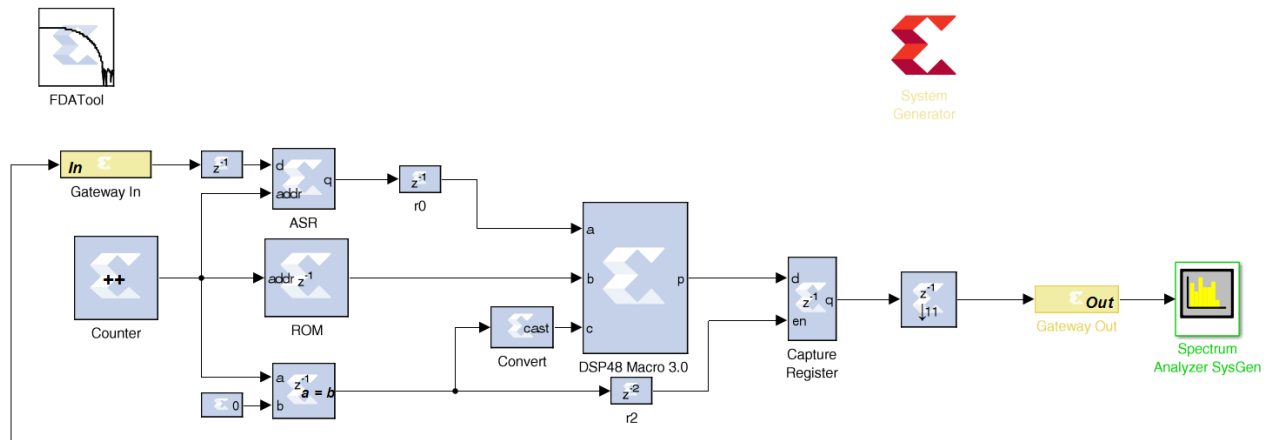

Figure 25: Discrete Filter Design

You will now configure the instances to correctly filter the data.

5. Double-click the **FDATool** instance and select **Filter Coefficients**  from the toolbar to review the filter specifications.

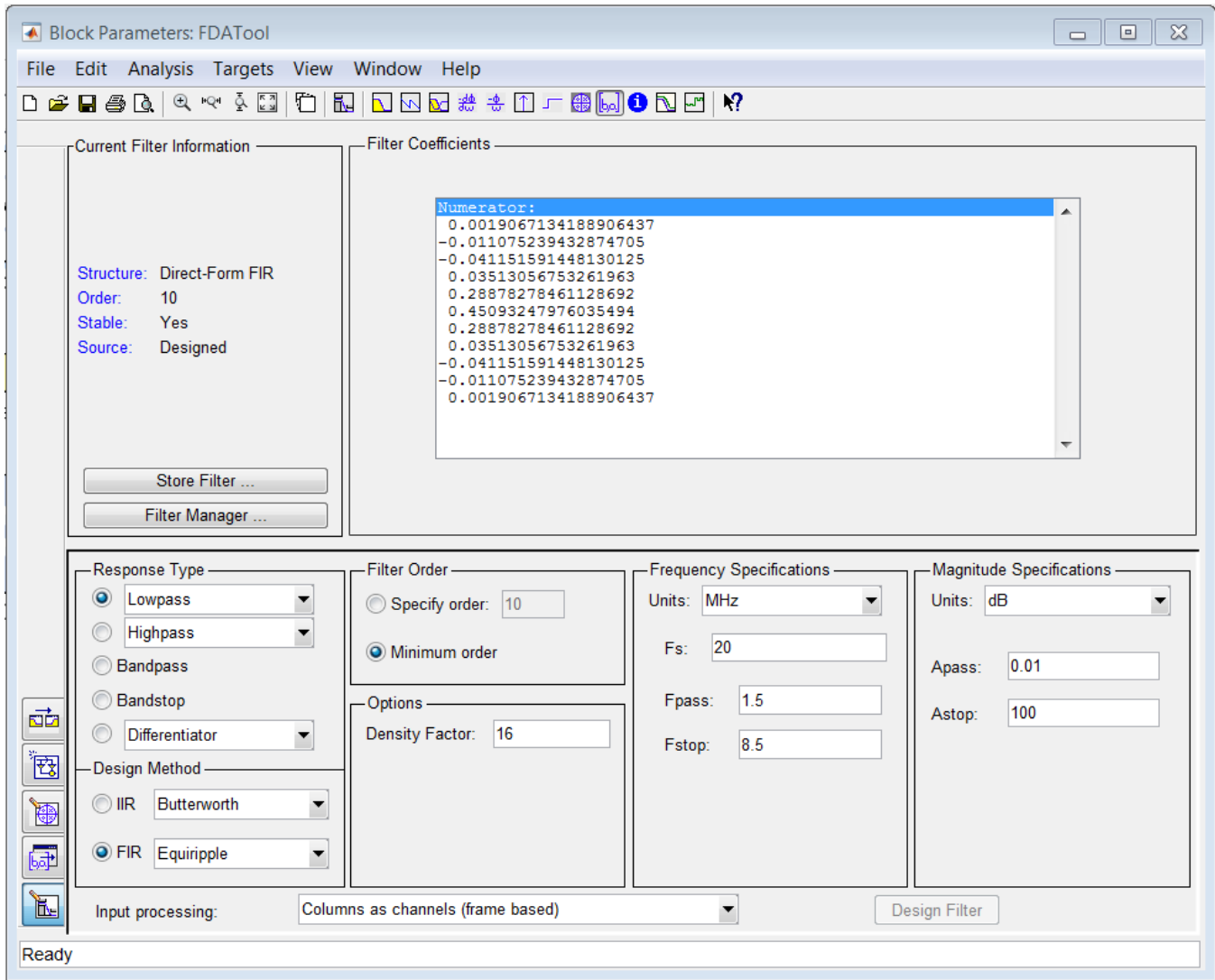

Figure 26: Lab1_3 Filter Specifications

This shows the same specifications as the previous steps in Lab 1 and confirms there are 11 coefficients. You can also confirm, by double-clicking on the input **Gateway In** that the input sample rate is once again 20 MHz (**Sample period** = $1/20 \times 10^6$). With this information, you can now configure the discrete components.

6. Close the **FDATool** Properties Editor.
7. Double-click the **Counter** instance to open the Properties Editor.
 - a. For the **Counter Type**, select **Count Limited** and enter this value:

```
length(xlfd_numerator('FDATool'))-1
```

This will ensure the counter counts from 0 to 10 (11 coefficient and data addresses).

- b. For **Output type**, leave default value at **Unsigned** and in **Number of Bits** enter the value 4. Only 4 binary address bits are required to count to 11.
- c. For the **Explicit period**, enter the value $1 / (11 * 20e6)$ to ensure the sample period is 11 times the input data rate. The filter must perform 11 calculations for each input sample.

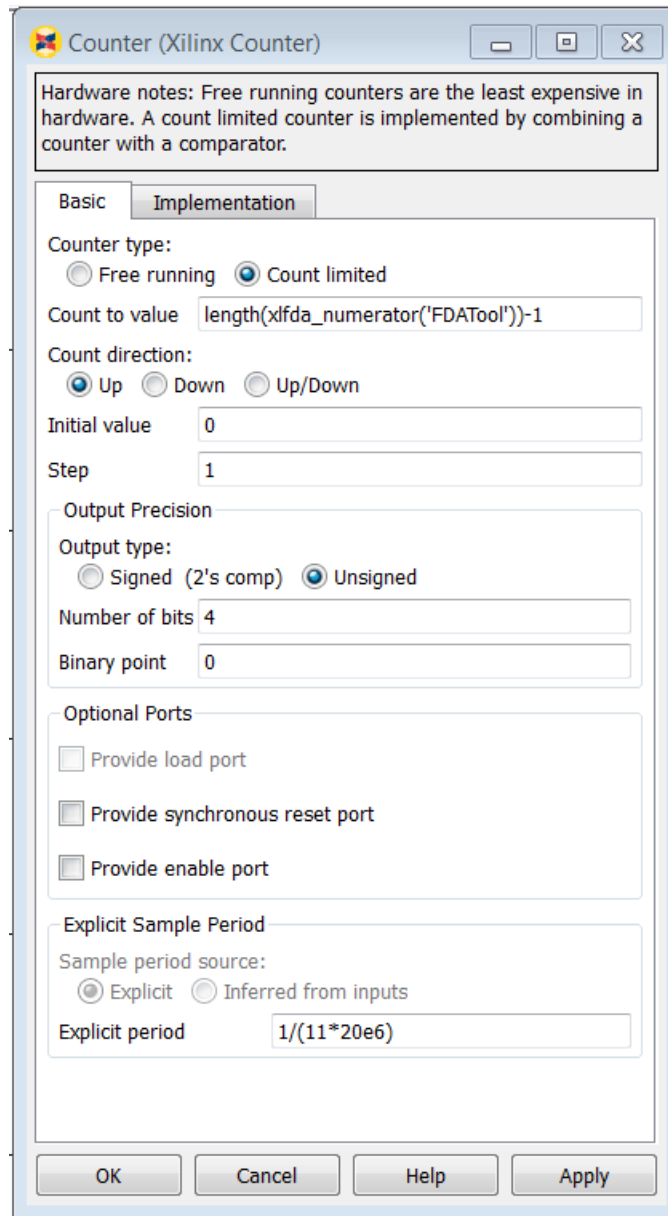

Figure 27: Counter Properties Editor

- d. Click **OK** to exit the Properties Editor.

8. Double-click the **ROM** instance to open the Properties Editor.
 - a. For the **Depth**, enter the value `length(xlfda_numerator('FDATool'))`. This will ensure the ROM has 11 elements.
 - b. For the **Initial value vector**, enter: `xlfda_numerator('FDATool')`. The coefficient values will be provided by the FDATool instance.

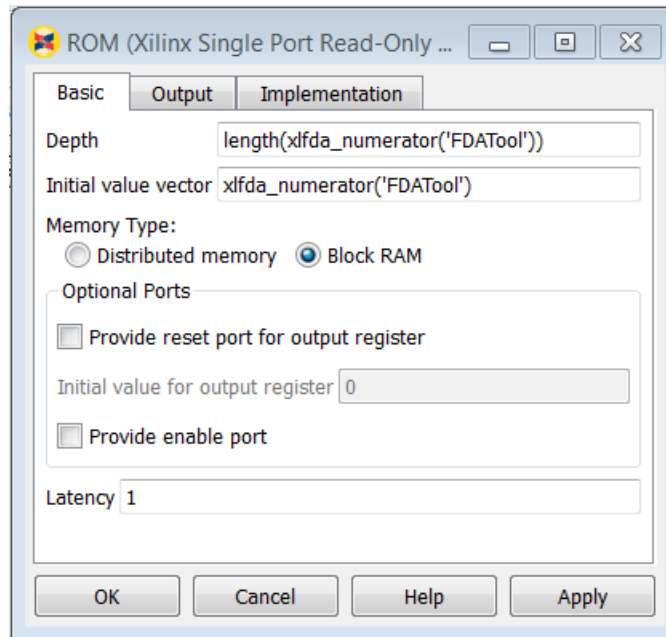

Figure 28: ROM Properties Editor

- c. Click **OK** to exit the Properties Editor.
9. Double-click the **DSP48 Macro 3.0** instance to open the Properties Editor.
 - a. In the **Instructions** tab, replace the existing Instructions with $A*B+P$ and then add $A*B$. When the sel input is false the DSP48 will multiply and accumulate. When the sel input is true the DSP48 will simply multiply.

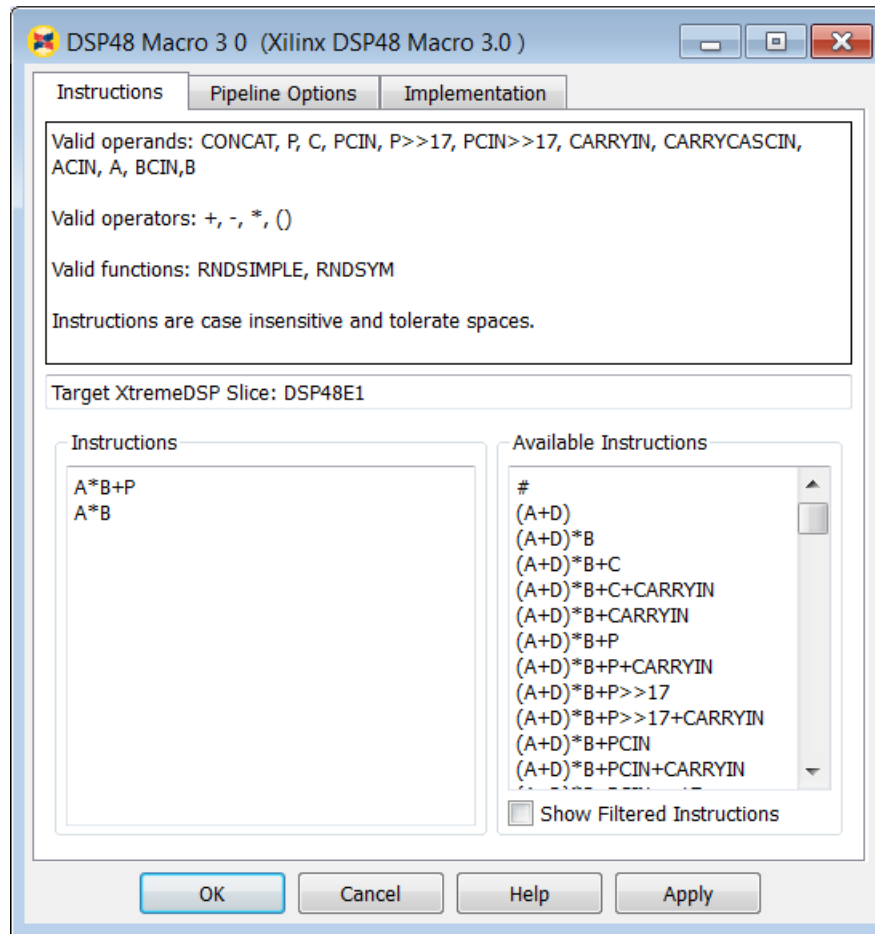

Figure 29: DSP48 Instructions Tab

- b. In the **Pipeline Options** tab, use the **Pipeline Options** drop-down menu to select **By_Tier**.
- c. Select **Tier 3** and **Tier 5**. This will ensure registers are used at the inputs to A and B and between the multiply and accumulate operations.

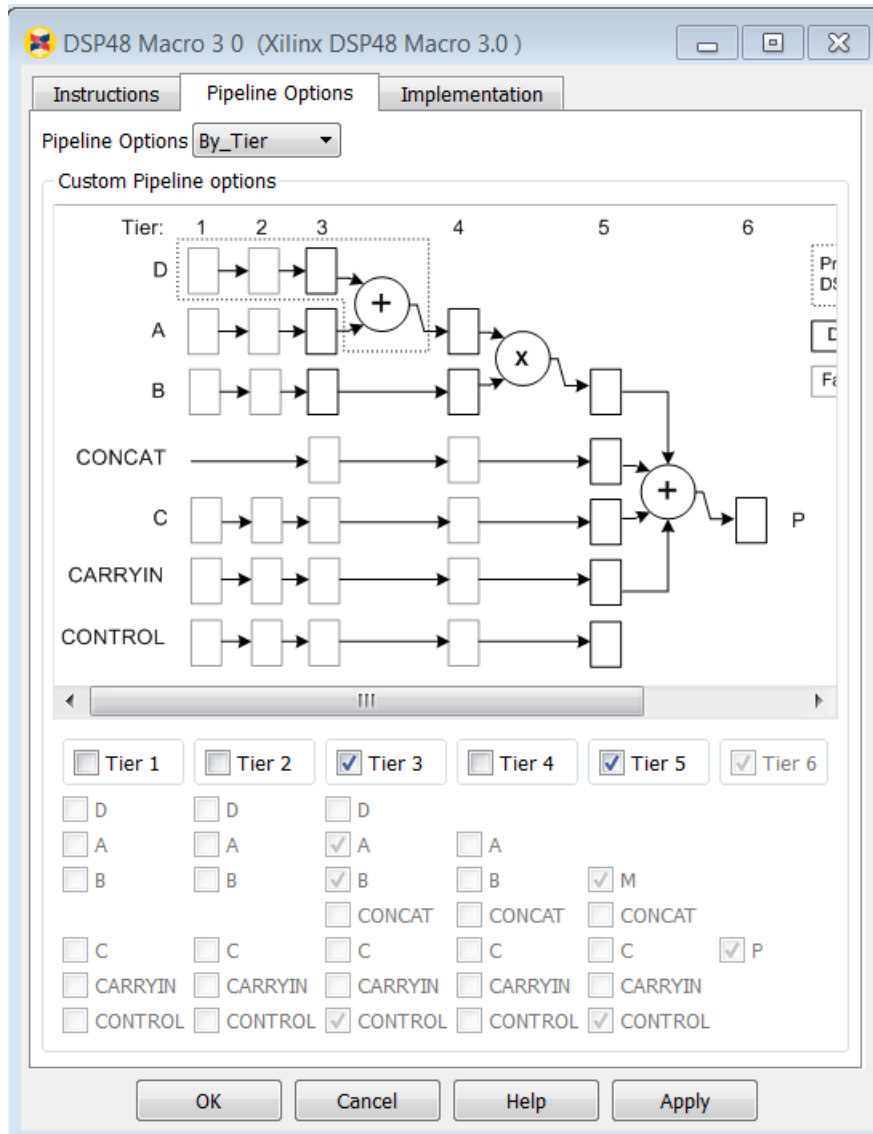

Figure 30: DSP48 Pipeline Options Tab

- d. Click **OK** to exit the Properties Editor.
- 10. Use the **Save** to save the design.
- 11. Click the **Run** simulation button to simulate the design and view the results, as shown in the figure below.

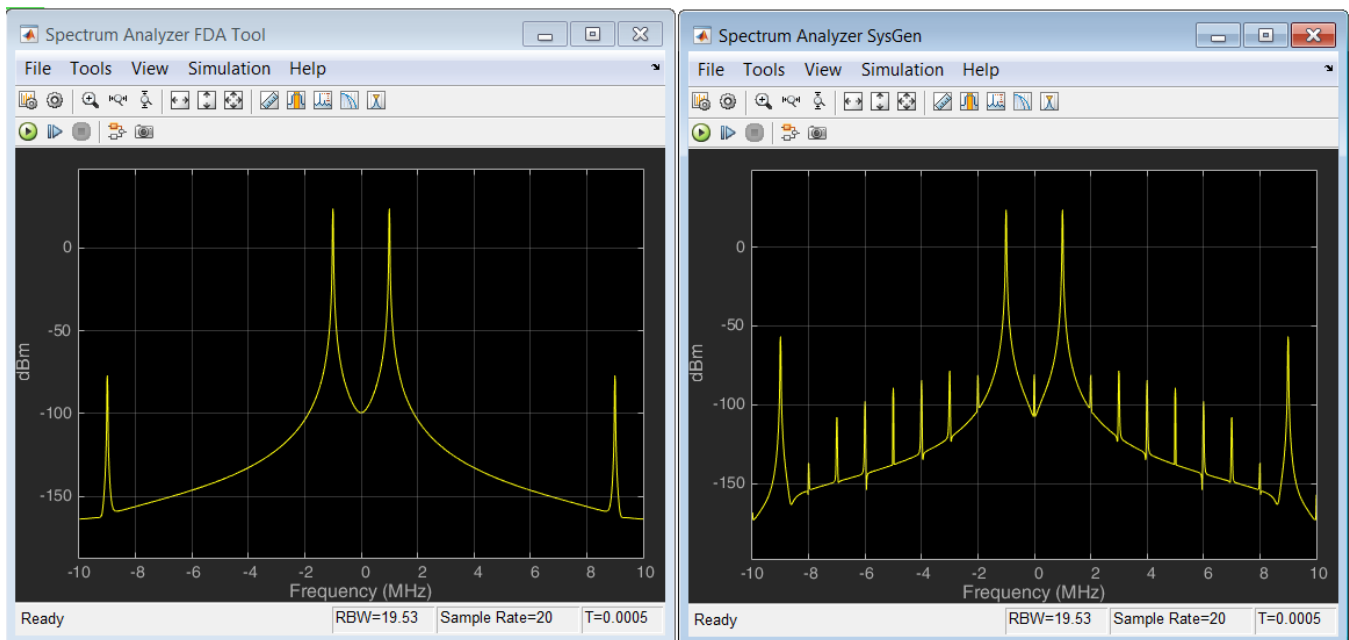

Figure 31: Discrete FIR Compiler Results

The final step is to compile the design into a hardware description and synthesize it.

12. Double-click the **System Generator** token to open the Properties Editor.
13. From the **Compilation** menu, make sure the **Compilation** target is IP Catalog.
14. Press **Generate** to compile the design into a hardware description.
15. Click **OK** to dismiss the Compilation status dialog box.
16. Click **OK** to dismiss the **System Generator** token.
17. Use one of these two alternatives to open the example Vivado project:
 - Use **Start > All Programs > Xilinx Design Tools > Vivado 2015.3 > Vivado 2015.3**, click **Open Project**, navigate to the folder `C:\SysGen_Tutorial\Lab1\netlist\ip_catalog` and select the file `lab1_3.xpr`.
 - OR
 - Navigate to `C:\SysGen_Tutorial\Lab1\netlist\ip_catalog` and double-click the file `lab1_3.xpr`.
18. Click the **Run Synthesis** button to synthesize the design into hardware.
19. When synthesis completes, select **View Reports** from the Synthesis Completed dialog box and click **OK**.
20. In the Utilization section of the Project Summary, click the **Table** tab to view a summary of the resources used in the post-synthesis design.

Resource	Estimation	Available	Utilization %
LUT	25	203800	0.01
LUTRAM	17	64000	0.03
FF	169	407600	0.04
BRAM	0.50	445	0.11
DSP	1	840	0.12
IO	65	400	16.25
BUFG	1	32	3.12

Graph **Table**

Post-Synthesis **Post-Implementation**

Figure 32: Lab1_3 Synthesis Results

The design now uses fewer FPGA hardware resources than either of the versions designed with the FIR Compiler macro (See [Figure 18: Lab1_1 Synthesis Results](#) and [Figure 22: Lab1_2 Synthesis Results](#)).

21. Exit the Vivado Design Suite.
22. Exit the Lab1_3.slx worksheet.

Summary

In this lab, you learned how to use the System Generator blockset to create a design in the Simulink environment and synthesize the design in hardware which can be implemented on a Xilinx FPGA. You learned the benefits of quickly creating your design using a Xilinx **FIR Compiler V7.2** block and how the design could be improved with the use of over-sampling.

Finally, you learned how you can take total control of the hardware implementation by using discrete primitives.

Note: In this tutorial you learned how to add System Generator blocks to the design and then configure them. A useful productivity technique is to add and configure the System Generator token first. If the target device is set at the start, some complex IP blocks will be automatically configured for the device when they are added to the design.

The following solutions directory contains the final System Generator (*.slx) files for this lab. The solutions directory does *not* contain the IP output from System Generator or the files and directories generated when Vivado is executed.

```
C:/SysGen_Tutorial/Lab1/solution
```

Lab 2: Working with Data Types

Introduction

In this lab exercise, you will learn how hardware-efficient fixed-point types can be used to create a design which meets the required specification but is more efficient in resources, and understand how to use Xilinx Blocksets to analyze these systems.

Objectives

After completing this lab, you will be able to:

- Understand the hardware implementation cost of a standard Simulink design.
- Implement the design using efficient Fixed-Point data types.
- Understand how to manipulate data types to ensure an optimal implementation of the design.

Procedure

This exercise has two primary parts.

- In Step 1 you will review and synthesize a design using floating-point data types.
- In Step 2 you will work with the same design, captured as a fixed-point implementation, and refine the data types to create a hardware-efficient design which meets the same requirements.

Step 1: Designing with Floating-Point Data Types

In this step you will review a design implemented with floating-point data types.

1. Invoke System Generator.
 - On Windows systems select **Start > All Programs > Xilinx Design Tools > Vivado 2015.3 > System Generator > System Generator 2015.3**.
 - On Linux systems, type `sysgen` at the command prompt.
2. Navigate to the Lab2 folder: `cd C:\SysGen_Tutorial\Lab2`.
 You can view the directory contents in the MATLAB Current Directory window, or type `ls` at the command line prompt.
3. At the command prompt, type `open Lab2_1.slx`

This opens the Simulink design shown in the following figure. This design is similar to the design used in Lab 1, however this time the design is using float data types and the filter is implemented in sub-system **FIR**.

First you will review the attributes of the design, then simulate the design to review the performance, and finally synthesize the design.

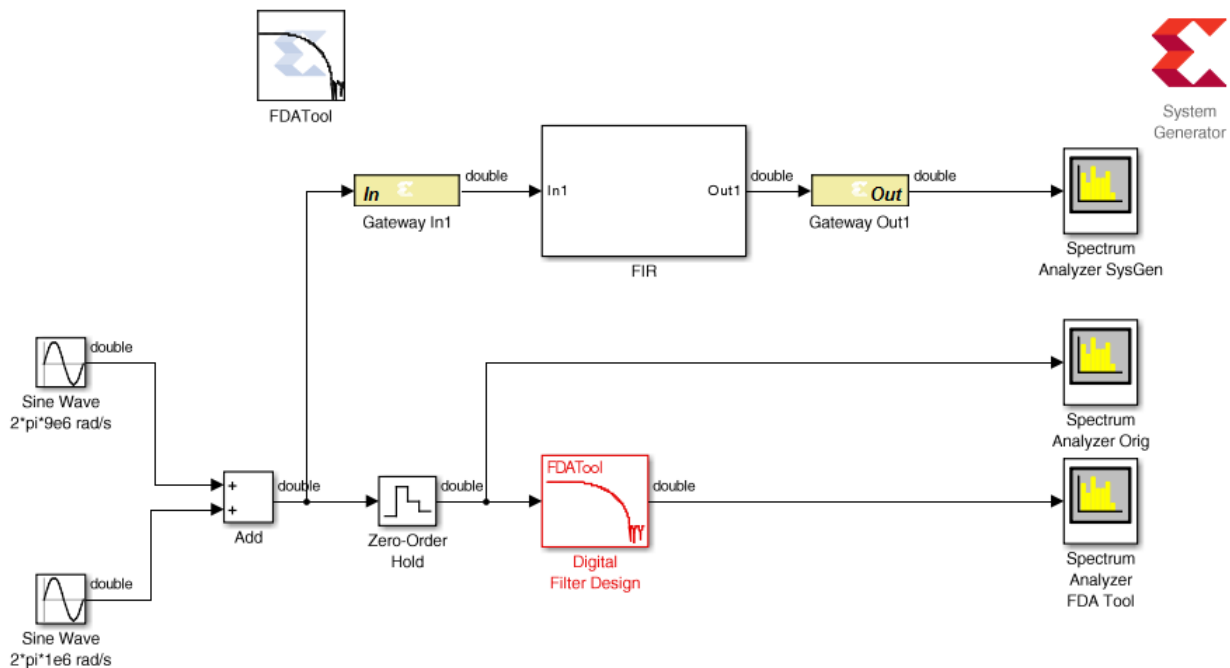

Figure 33: Initial Lab2_1 Design

As you can see in the figure above, both the input and output of instance **FIR** are of type double.

4. In the MATLAB Command Window type `MyCoeffs = xlfda_numerator('FDATool');`
5. Double-click the instance **FIR** to open the sub-system.
6. Double-click the instance **Constant1** to open the Properties Editor.

This shows the **Constant value** is defined by `MyCoeffs(1)`.

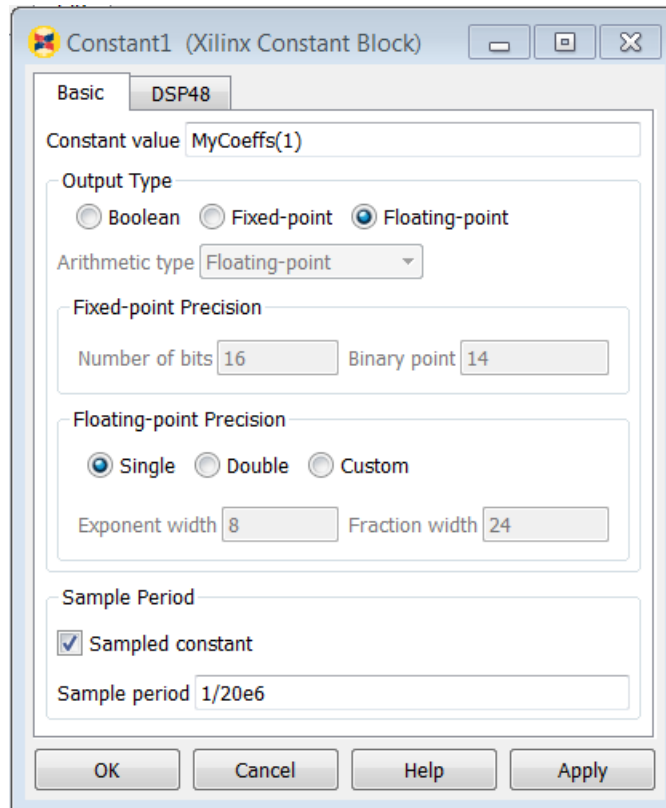



Figure 34: Constant1 Properties Editor

7. Return to the top-level design using the toolbar button  or click on the tab labeled **Lab2_1**.

The design is summing two sine waves, both of which are 9 MHz. The input gateway to the System Generator must therefore sample at a rate of at least 18 MHz.

8. Double-click the **Gateway In1** instance to open the Properties Editor and confirm the input is sampling the data at a rate of 20 MHz.
9. Close the **Gateway In** Properties editor.
10. Press the **Run** simulation button to simulate the design.

The results shown below show the System Generator blockset produces results which are very close to the ideal case, shown in the center. The results are not identical because the System Generator design must sample the continuous input waveform into discrete time values.

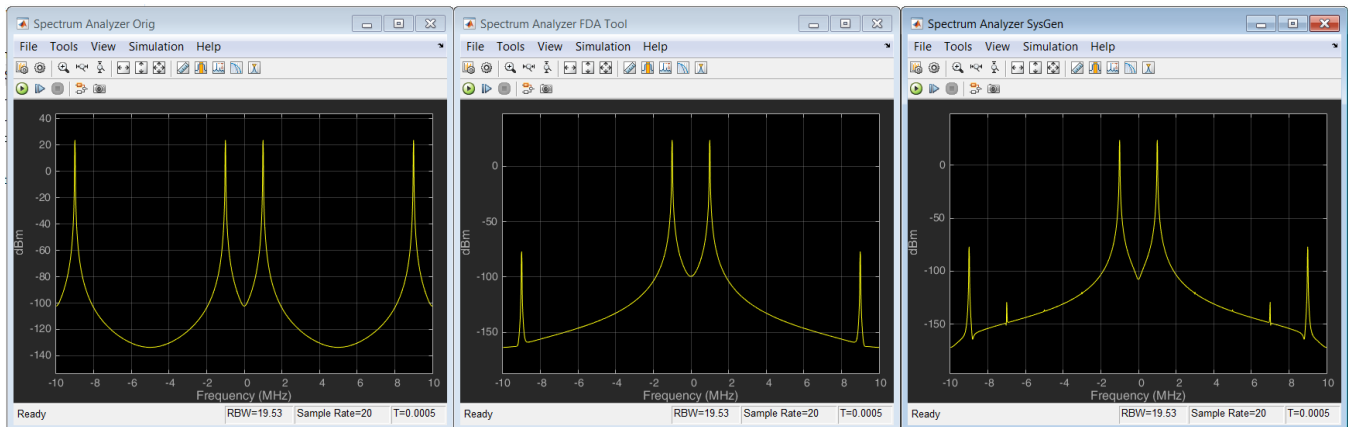

Figure 35: Lab2_1 Simulation Results

The final step is to synthesize this design into hardware

11. Double-click the **System Generator** token to open the Properties Editor.
12. From the **Compilation** menu, make sure the **Compilation** target is IP Catalog.
13. Press **Generate** to compile the design into a hardware description.
14. Click **OK** to dismiss the Compilation status dialog box.
15. Click **OK** to dismiss the **System Generator** token.
16. Use one of these two alternatives to open the example Vivado project:
 - Use **Start > All Programs > Xilinx Design Tools > Vivado 2015.3 > Vivado 2015.3**, click **Open Project**, navigate to the folder `C:\SysGen_Tutorial\Lab2\netlist\ip_catalog` and select file `lab2_1.xpr`.
 - OR
 - Navigate to `C:\SysGen_Tutorial\Lab2\netlist\ip_catalog` and double-click the file `lab2_1.xpr`.
17. In the Vivado Flow Navigator, click the **Run Synthesis** button to synthesize the design into hardware.
18. When synthesis completes, select **View Reports** from the Synthesis Completed dialog box and click **OK**.
19. In the Utilization section of the Project Summary, click the **Table** tab to view a summary of the resources used.

Resource	Estimation	Available	Utilization %
LUT	4805	203800	2.36
LUTRAM	320	64000	0.50
FF	1332	407600	0.33
DSP	33	840	3.93
IO	65	400	16.25
BUFG	1	32	3.12

Figure 36: Lab2_1 Synthesis Results

You implemented this same filter in Lab 1 using fixed-point data types. When compared to the synthesis results from that implementation – the initial results from Lab 1 are shown below in [Figure 37: Lab1_1 Synthesis Results](#) and you can see this current version of the design is using a large amount of registers, LUTs and DSP48 resources (Xilinx dedicated multiplier/add units).

Resource	Estimation	Available	Utilization %
LUT	168	203800	0.08
LUTRAM	161	64000	0.25
FF	298	407600	0.07
DSP	6	840	0.71
IO	50	400	12.50
BUFG	1	32	3.12

Figure 37: Lab1_1 Synthesis Results

Maintaining the full accuracy of floating-point types is an ideal implementation but implementing full floating-point accuracy requires a significant amount of hardware.

For this particular design, the entire range of the floating-point types is not required. The design is using considerably more resources than what is required. In the next step, you will learn how to compare designs with different data types inside the Simulink environment.

20. Exit the Vivado Design Suite.

21. Exit the `Lab2_1.slx` worksheet.

Step 2: Designing with Fixed-Point Data Types

In this step you will re-implement the design from [Step 1: Designing with Floating-Point Data Types](#) using fixed-point data types, and compare this new design with the original design. This exercise will demonstrate the advantages and disadvantages of using fixed-point types and how System Generator allows you to easily compare the designs, allowing you to make trade-offs between accuracy and resources within the Simulink environment before committing to an FPGA implementation.

1. At the command prompt, type `open Lab2_2.slx` to open the design shown below.

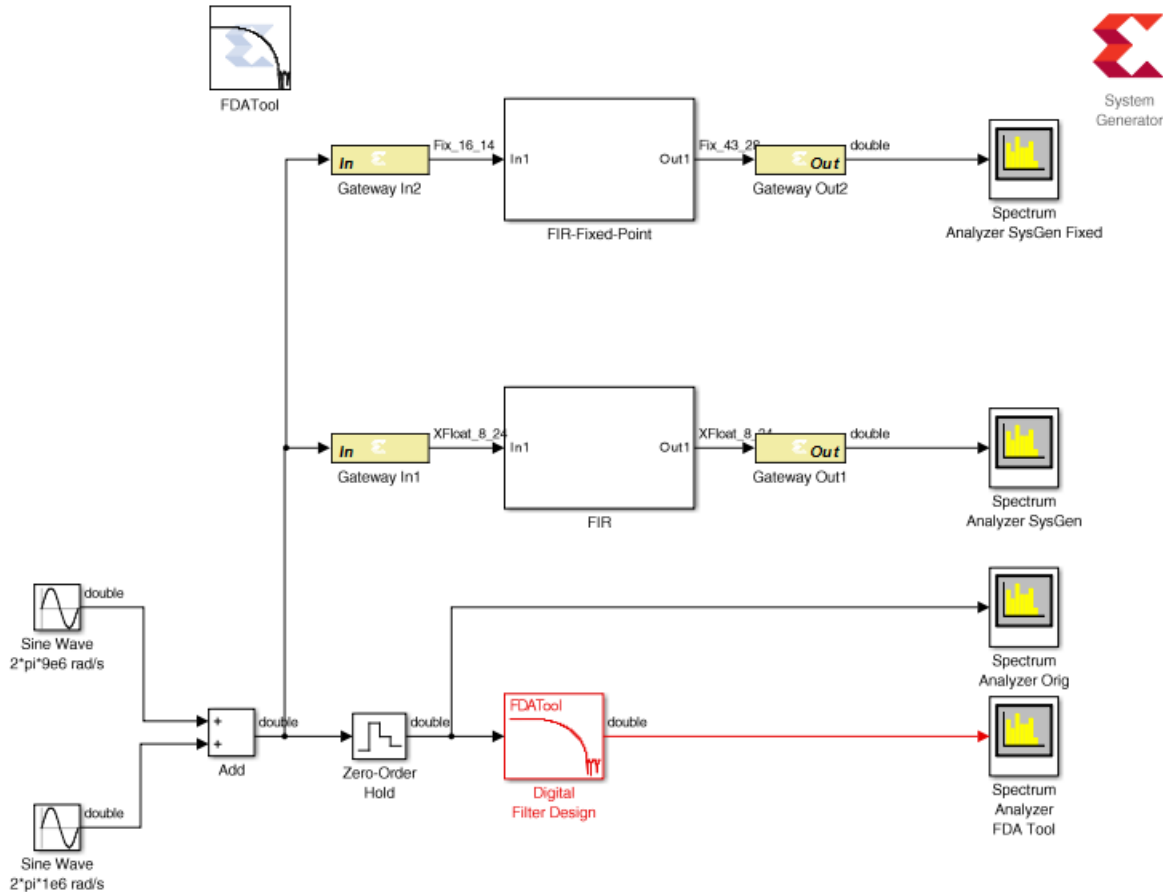

Figure 38: Lab2_2 Design

In this design, the floating-point implementation is captured alongside an identical fixed point design.

2. In the MATLAB Command Window type `MyCoeffs = xlfda_numerator('FDATool');`
3. Double-click the instance **Gateway In2** to confirm the data is being sampled as 16-bit fixed-point value.
4. Click **Cancel** to exit the Properties Editor.
5. Click the **Run** simulation button to simulate the design and confirm instance **Spectrum Analyzer SysGen Fixed** shows the filtered output.

As you will see if you examine the output of instance **FIR-Fixed-Point** (shown in [Figure 38: Lab2_2 Design](#)) System Generator has automatically propagated the input data type through the filter and determined the output must be 43-bit (with 28 binary bits) to maintain the resolution of the signal.

This is based on the bit-growth through the filter and the fact that the filter coefficients (constants in instance **FIR-Fixed-Point**) are 16-bit.

6. In the MATLAB Command Window, enter `sum(abs(MyCoeffs))` to determine the absolute maximum gain using the current coefficients.

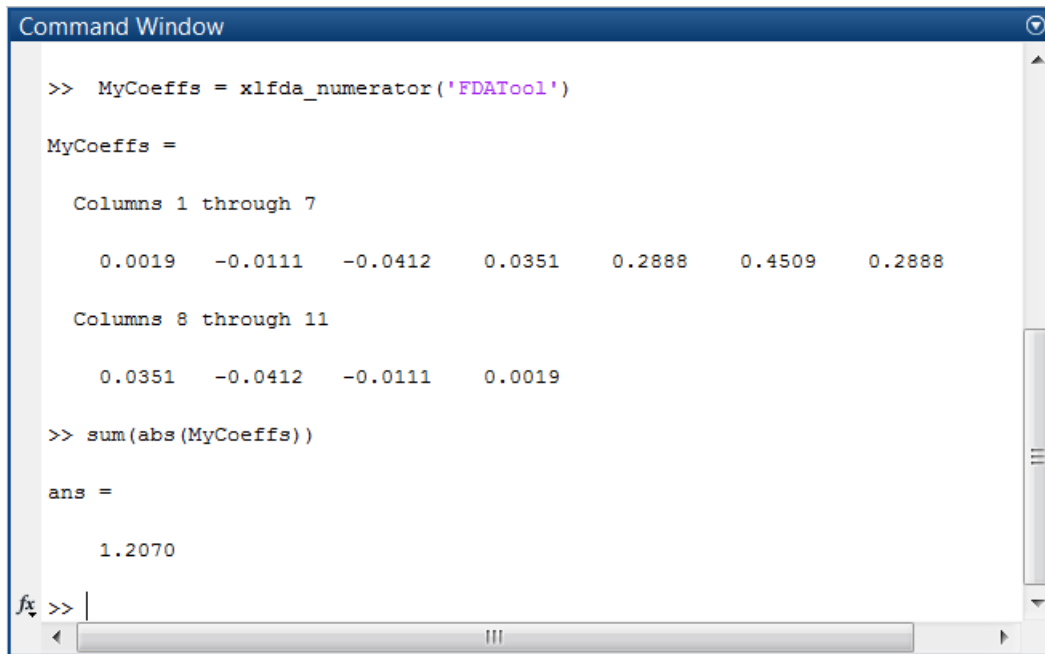

```

Command Window

>> MyCoeffs = xlfda_numerator('FDATool')

MyCoeffs =

Columns 1 through 7

    0.0019   -0.0111   -0.0412    0.0351    0.2888    0.4509    0.2888

Columns 8 through 11

    0.0351   -0.0412   -0.0111    0.0019

>> sum(abs(MyCoeffs))

ans =

    1.2070
    
```

Figure 39: Lab2_2 Coefficient Sum

Taking into account the positive and negative values of the coefficients the maximum gain possible is 1.2070 and the output signal should only ever be slightly smaller in magnitude than the input signal, which is a 16-bit signal. There is no need to have 15 bits (43-28) of data above the binary point.

You will now use the **Reinterpret** and **Convert** blocks to manipulate the fixed-point data to be no greater than the width required for an accurate result and produce the most hardware efficient design.

7. Right-click with the mouse anywhere in the canvas and select **Xilinx BlockAdd**.
8. In the Add Block entry box, type `Reinterpret`.
9. Double-click the **Reinterpret** component to add it to the design.
10. Repeat the previous three steps for these components:
 - a. Convert
 - b. Scope
11. In the design, select the **Gateway Out2** instance.
 - a. Right-click and use Copy and Paste to create a new instance of the Gateway Out block.
 - b. Paste twice again to create two more instances of the Gateway Out (for a total of 3 new instances).

12. Connect the blocks as shown in the figure below.
13. Rename the signal names into the scope as shown in the figure below: Convert, Reinterpret and Growth.

To rename a signal, click the existing name label and edit the text.

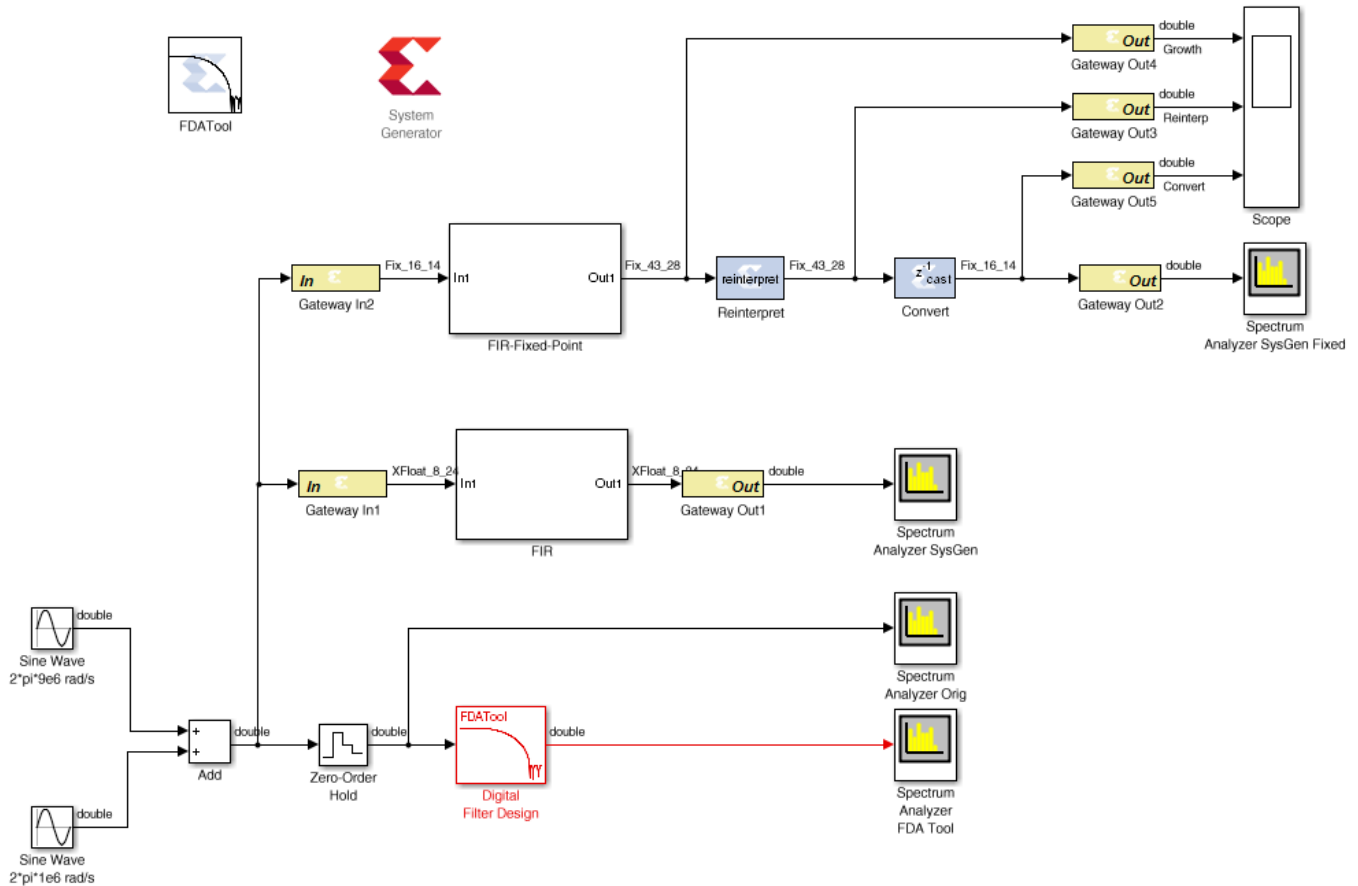

Figure 40: Updated Lab2_2 Design

14. Click the **Run** simulation button to simulate the design.
15. Double-click the Scope to examine the signals.



TIP: You may need to zoom in and select autoscale to view the signals in detail.

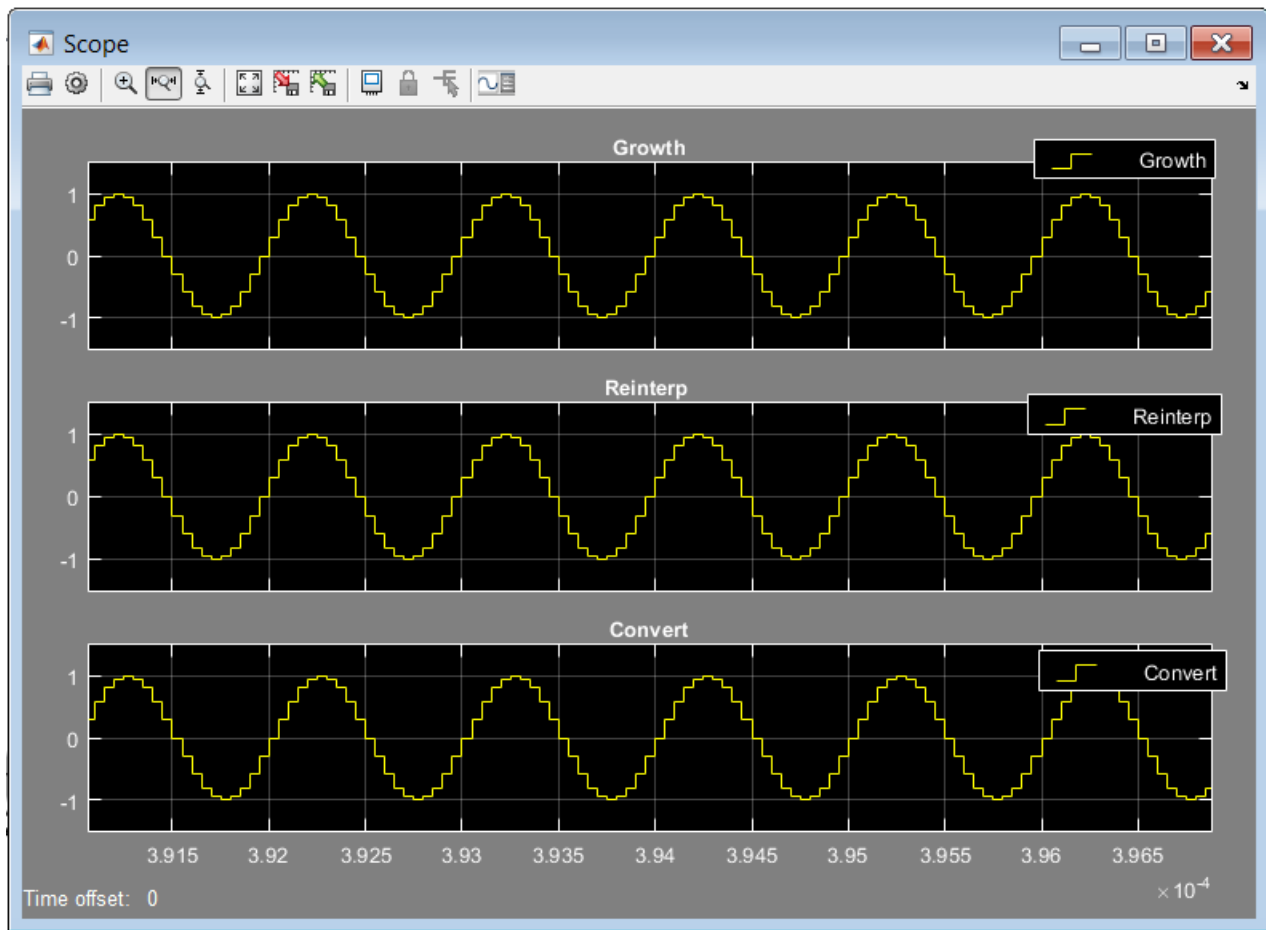

Figure 41: Updated Lab2_2 Design Scope

The Reinterpret and Convert blocks have not been configured at this point and so all three signals are identical.

The Xilinx Reinterpret block forces its output to a new type without any regard for retaining the numerical value represented by the input. The block allows for unsigned data to be reinterpreted as signed data, or, conversely, for signed data to be reinterpreted as unsigned. It also allows for the reinterpretation of the data's scaling, through the repositioning of the binary point within the data.

In this exercise you will scale the data by a factor of 2 to model the presence of additional design processing which may occur in a larger system. The Reinterpret block may also be used to scale down.

16. Double-click the **Reinterpret** block to open the Properties Editor.

17. Select **Force Binary Point**.

18. Enter the value 27 in the input field **Output Binary Point** and click **OK**.

The Xilinx Convert block converts each input sample to a number of a desired arithmetic type. For example, a number can be converted to a signed (two's complement) or unsigned value. It also allows

the signal quantization to be truncated or rounded and the signal overflow to be wrapped, saturated, or to be flagged as an error.

In this exercise, you will use the Convert block to reduce the size of the 43-bit word back to a 16-bit value. In this exercise the Reinterpret block has been used to model a more complex design and scaled the data by a factor of 2. You must therefore ensure the output has enough bits above the binary point to represent this increase.

19. Double-click the **Convert** block to open the Properties Editor.
20. In the Fixed-Point Precision section, enter 13 for the **Binary Point** and click **OK**.
21. Save the design.
22. Click the **Run** simulation button to simulate the design.
23. Double-click the **Scope** to examine the signals.



TIP: You may need to zoom in and select autoscale to view the signals in detail.

In the figure below you can see the output from the filter (Growth) has values between plus and minus one. The output from the Reinterpret block moves the data values to between plus and minus two. In this detailed view of the waveform, the final output (Convert) shows no difference in fidelity, when compared to the reinterpret results, but uses only 16 bits.

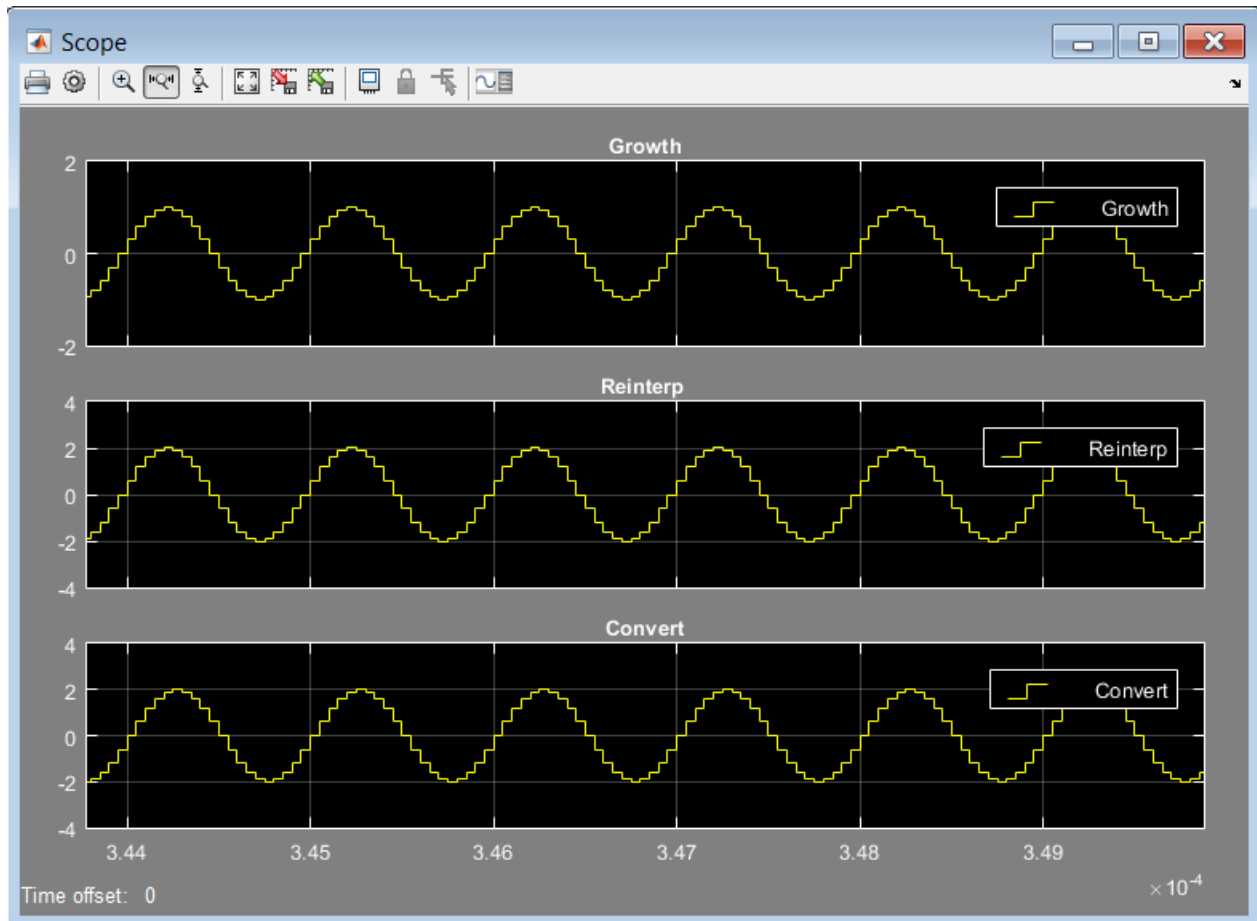

Figure 42: Scaled Lab2_2 Design Scope

The final step is to synthesize this design into hardware.

24. Double-click the **System Generator** token to open the Properties Editor.
25. From the **Compilation** menu, make sure the **Compilation** target is IP Catalog.
26. Press **Generate** to compile the design into a hardware description.
27. Click **OK** to dismiss the Compilation status dialog box.
28. Click **OK** to dismiss the **System Generator** token.
29. Use one of these two alternatives to open the example Vivado project:
 - a. Use **Start > All Programs > Xilinx Design Tools > Vivado 2015.3 > Vivado 2015.3**, click **Open Project**, navigate to the folder `C:\SysGen_Tutorial\Lab2\netlist\ip_catalog` and select file `lab2_2.xpr`.

OR

- b. Navigate to C:\SysGen_Tutorial\Lab2\netlist\ip_catalog and double-click the file lab2_2.xpr.
- 30. In the Vivado Flow Navigator, click the **Run Synthesis** button to synthesize the design into hardware.
- 31. When synthesis completes, select **View Reports** from the Synthesis Completed dialog box and click **OK**.
- 32. In the Utilization section of the Project Summary, click the **Table** tab to view a summary of the resources used.

Resource	Estimation	Available	Utilization %
LUT	5394	203800	2.65
LUTRAM	480	64000	0.75
FF	1926	407600	0.47
DSP	44	840	5.24
IO	199	400	49.75
BUFG	1	32	3.12

Graph **Table**

Figure 43: Lab2_2 Synthesis Results

Notice, as compared to the results in Step 1 ([Figure 36: Lab2_1 Synthesis Results](#)) these results show approximately

- 45% more Flip-Flops
- 20% more LUTs
- 30% more DSP48s

However, this design contains both the original floating-point filter and the new fixed-point version: the fixed-point version therefore uses approximately 75-50% fewer resources with the acceptable signal fidelity and design performance.

- 33. Exit the Vivado Design Suite.
- 34. Exit the Lab2_2.slx worksheet.

Summary

In this lab, you learned how floating-point types provide a high degree of accuracy but cost many more resources to implement in an FPGA. You also learned how the System Generator blockset can be used to both implement a design using more efficient fixed-point data types and compensate for any loss of accuracy caused by using fixed-point types.

The Reinterpret and Convert blocks are powerful tools which allow you to optimize your design without needing to perform detailed bit-level optimizations. You can simply use these blocks to convert between different data types and quickly analyze the results.

The following solutions directory contains the final System Generator (*.slx) files for this lab. The solutions directory does *not* contain the IP output from System Generator or the files and directories generated when Vivado is executed.

```
C:/SysGen_Tutorial/Lab2/solution
```

Lab 3: Working with Multi-Rate Systems

Introduction

In this lab exercise, you will learn how to efficiently implement designs with multiple data rates using multiple clock domains.

Objectives

After completing this lab, you will be able to:

- Understand the benefits of using multiple clock domains to implement multi-rate designs.
- Understand how to isolate hierarchies using FIFOs to create safe channels for transferring asynchronous data.
- How to implement hierarchies with different clocks.

Procedure

This exercise has three primary parts.

- In Step 1, you will learn how to create hierarchies between the clock domains.
 - In Step 2, you will learn how to add FIFOs between the hierarchies.
 - In Step 3, you will learn how to add separate clock domains for each hierarchy.
-

Step 1: Creating Clock Domain Hierarchies

In this step you will review a design in which different parts of the design operate at different data rates and partition the design into subsystems to be implemented in different clock domains.

1. Invoke System Generator.
 - On Windows systems select **Start > All Programs > Xilinx Design Tools > Vivado 2015.3 > System Generator > System Generator 2015.3**.
 - On Linux Systems, type **sysgen** at the command prompt.
2. Navigate to the Lab3 folder: `cd C:\SysGen_Tutorial\Lab3`.
3. At the command prompt, type `open Lab3_1.slx`

This opens the Simulink design shown in the following figure. This design is composed of three basic parts:

- The channel filter digitally converts the incoming signal (491.52 MSPS) to near baseband (61.44 MSPS) using a classic multi-rate filter: the use of two half-band filters followed by a decimation of 2 stage filter, which requires significantly fewer coefficients than a single large filter.
- The output section gain-controls the output for subsequent blocks which will use the data.
- The gain is controlled from the POWER_SCALE input.

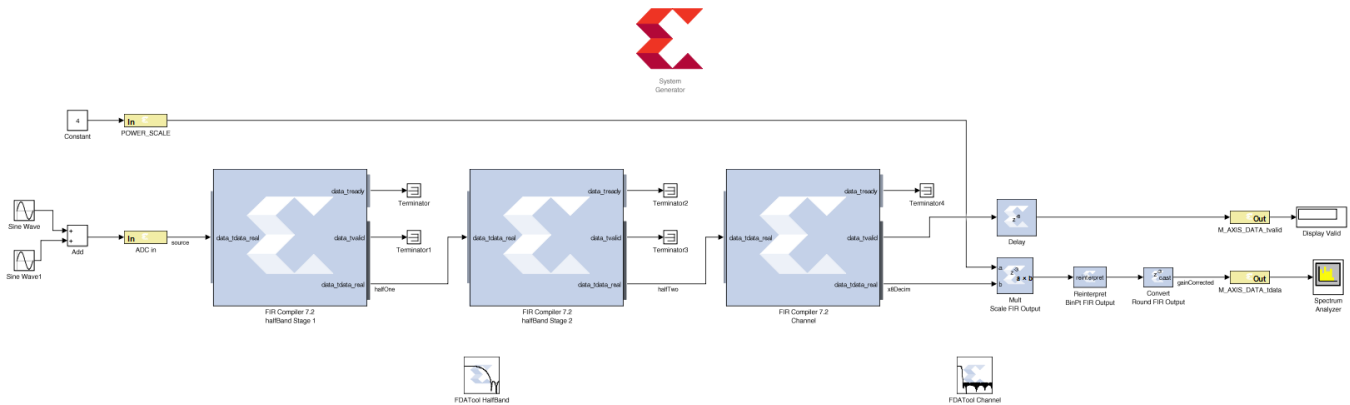

Figure 44: Initial Lab3_1 Design

4. Click the **Run** simulation button to simulate the design.

In the following figure Sample Time Display is enabled with colors (right-click in the canvas > **Sample Time Display** > **Colors**) and shows the design is clearly running at multiple data rates.

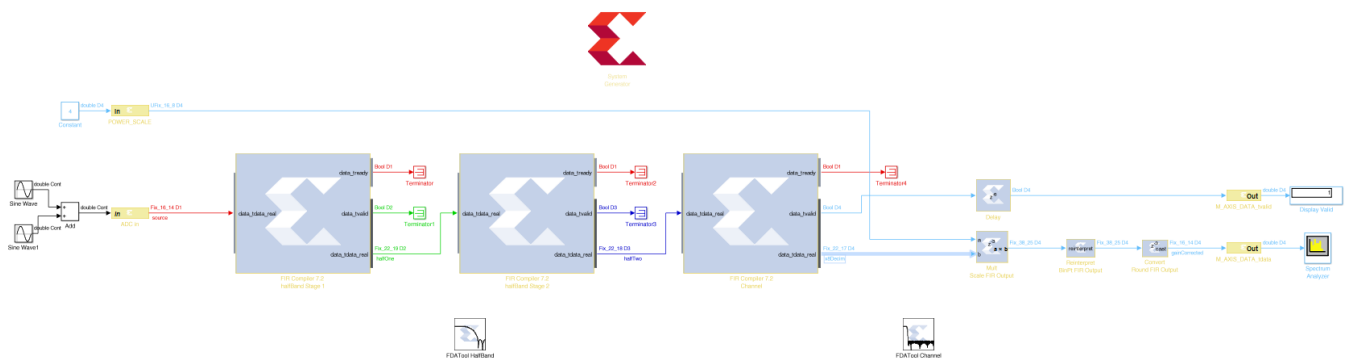

Figure 45: Lab3_1 Display After Simulation

The System Generator environment automatically propagates the different data rates through the design. When a multi-rate design such as this is implemented in hardware, the most optimal implementation is to use a clock at the same frequency as the data; however, the clock is abstracted

away in this environment. The following methodology demonstrates how to create this ideal implementation in the most efficient manner.

To efficiently implement a multi-rate (or multi-clock) design using System Generator you should capture each part running at the same data rate (or clock frequency) in its own hierarchy with its own **System Generator** token. The separate hierarchies should then be linked with FIFOs.

The current design has two obvious, and one less obvious, clock domains:

- The gain control input POWER_SCALE could be configurable from a CPU and therefore can run at the same clock frequency as the CPU.
- The actual gain-control logic on the output stage should run at the same frequency as the output data from the FIR. This will allow it to more efficiently connect to subsequent blocks in the system.
- The less obvious region is the filter-chain. Remember from Lab 1 that complex IP provided with System Generator, such as the FIR Compiler, automatically takes advantage of over-clocking to provide the most efficient hardware. For example, rather than use 40 multipliers running at 100 MHz, the FIR Compiler will use only 8 multipliers if clocked at 500 MHz ($= 40 \cdot 100 / 500$). The entire filter chain can therefore be grouped into a single clock domain. The first FIR Compiler instance will execute at the maximum clock rate and subsequent instances will automatically take advantage of over-sampling.

You will start by grouping these regions into different hierarchies.

5. Select all the blocks in the filter chain – all those to be in the same clock domain, including the FDATool instances - as shown below.
6. Select **Create Subsystem**, also as shown in the figure below, to create a new subsystem.

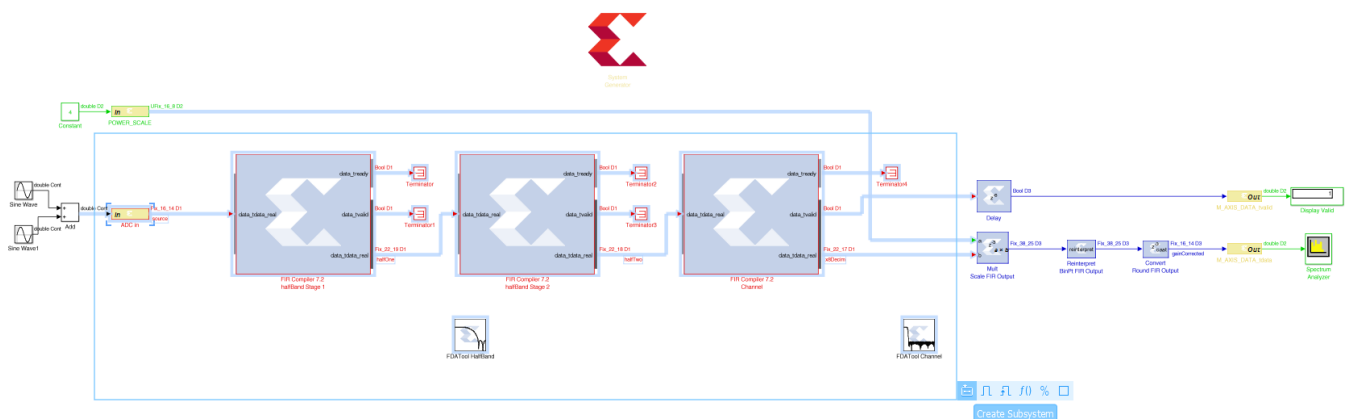

Figure 46: Create DDC Subsystem

7. Select the instance name subsystem and change this to DDC to obtain the design shown.

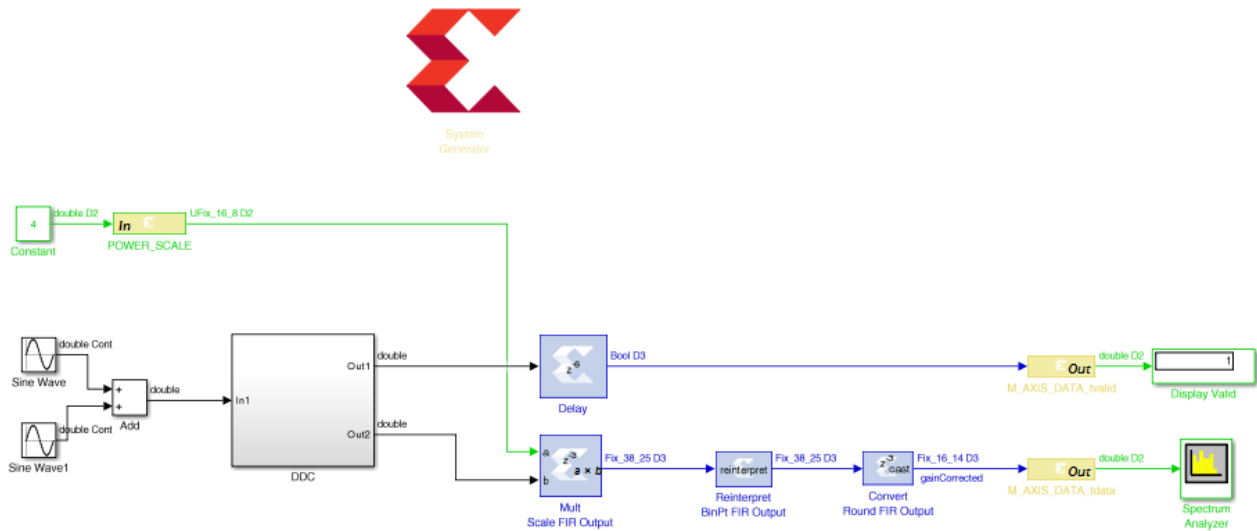

Figure 47: Lab3_1 with DDC Subsystem

8. Select the components in the output path and create a subsystem named **Gain Control**.

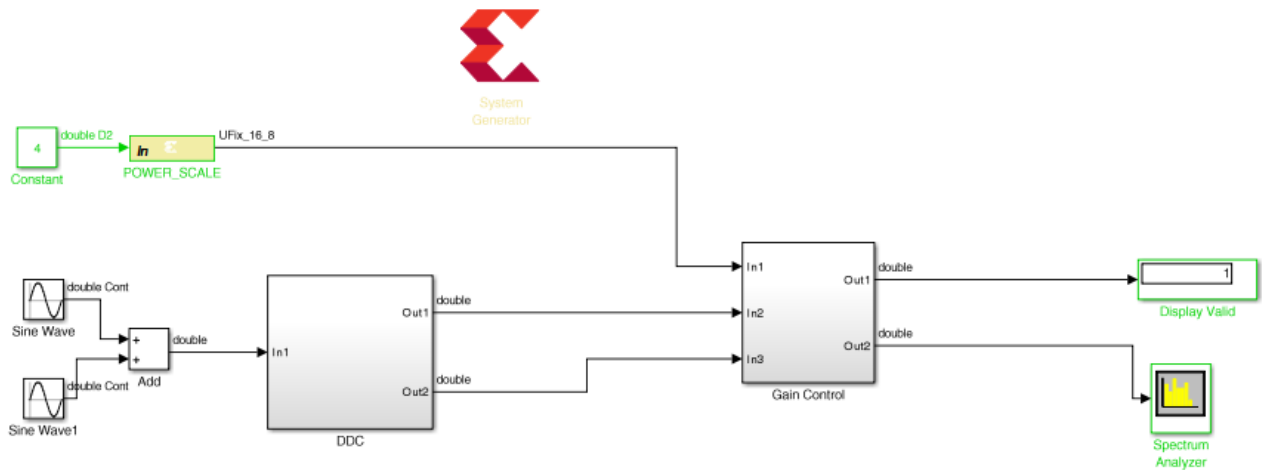

Figure 48: Lab3_1 with Gain Control Subsystem

9. Finally, select the Gateway In instance **POWER_SCALE** and **Constant** to create a new subsystem called **CTRL**. The final grouped design is shown below.

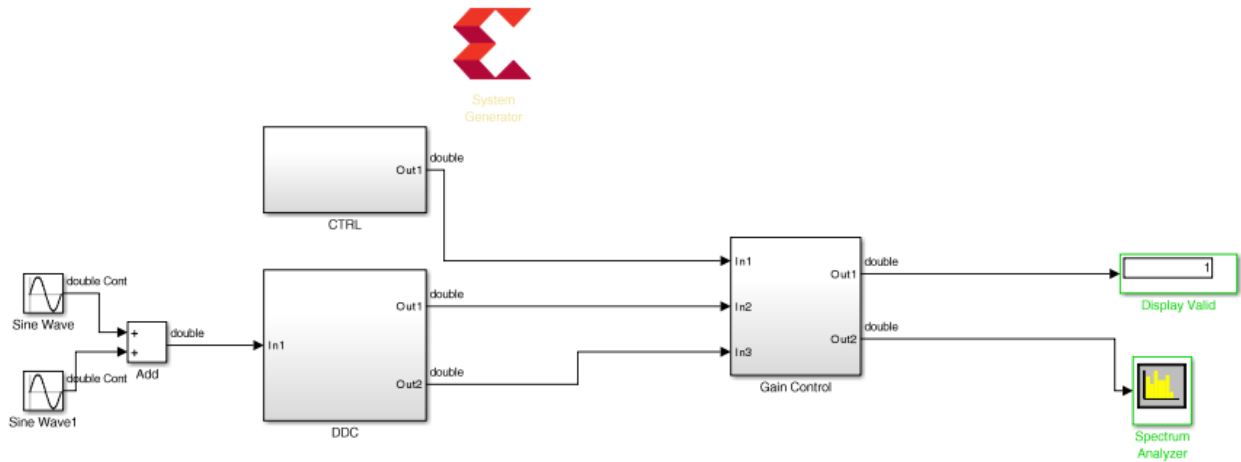

Figure 49: Lab3_1 with Domain Subsystems

When this design is complete, the logic within each subsystem will execute at different clock frequencies. The clock domains might not be synchronous with each other. There is presently nothing to prevent incorrect data being sampled between one subsystem and another subsystem.

In the next step you will create asynchronous channels between the different domains to ensure data will asynchronously and safely cross between the different clock domains when the design is implemented in hardware.

Step 2: Creating Asynchronous Channels

In this step you will implement asynchronous channels between subsystems using FIFOs. The data in FIFOs operates on a First-In-First-Out (FIFO) basis, and control signals ensure data is only read when valid data is present and data is only written when there is space available. If the FIFO is empty or full the control signals will stall the system. In this design the inputs will always be capable of writing and there is no requirement to consider the case for the FIFO being full.

There are two data paths in the design where FIFOs are required:

- Data from **CTRL** to **Gain Control**.
- Data from **DDC** to **Gain Control**.

1. Right-click anywhere in the canvas and select **Xilinx BlockAdd**.
2. Type `FIFO` in the Add Block dialog box.
3. Select **FIFO** from the menu to add a FIFO to the design.
4. Connect the data path through instance **FIFO**. Delete any existing connections to complete this task.
 - a. Connect CTRL/Out1 to FIFO/din.
 - b. Connect FIFO/dout to Gain Control/In1.
5. Make a copy of the **FIFO** instance (using Ctrl-C and Ctrl-V to copy and paste).
6. Connect the data path through instance **FIFO1**. Delete any existing connections to complete this task.
 - a. Connect DDC/Out2 to FIFO1/din.
 - b. Connect FIFO1/dout to Gain Control/In3.

You have now connected the data between the different domains and have the design shown below.

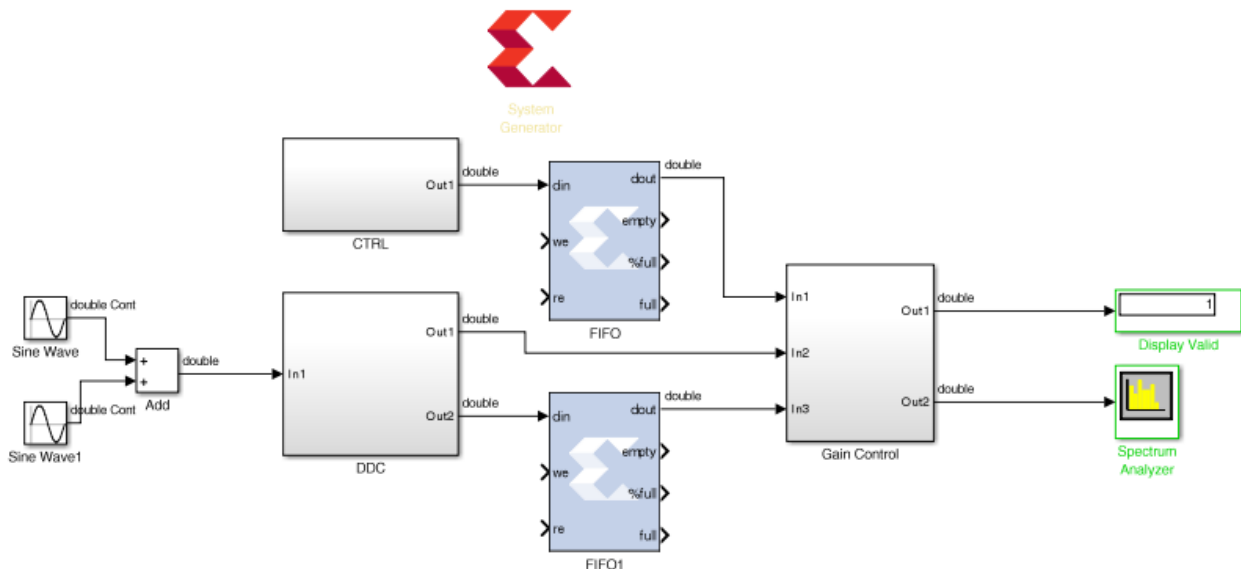

Figure 50: Lab3_1 with FIFO Data Channels

You will now connect up the control logic signals to ensure the data is safely passed between domains.

- From the **CTRL** block a write enable is required. This is not currently present and needs to be created.
- From the **DDC** block a write enable is required. The `data_tvalid` from the final FIR stage may be used for this.

- The **Gain Control** must generate a read enable for both FIFOs. You will use the empty signal from the FIFOs and invert it; if there is data available, this block will read it.
7. Double-click the **CTRL** block to open the subsystem.
 8. Right-click in the canvas and use **Xilinx BlockAdd** to add these blocks:
 - a. Delay (Xilinx)
 - b. Relational
 9. Select instance `Out1` and make a copy (use Ctrl-C and Ctrl-V to cut and paste).
 10. Double-click the **Relational** block to open the Properties Editor.
 11. Use the **Comparison** drop-down menu to select `a!=b` and click **OK**.
 12. Connect the blocks as shown in the following figure.

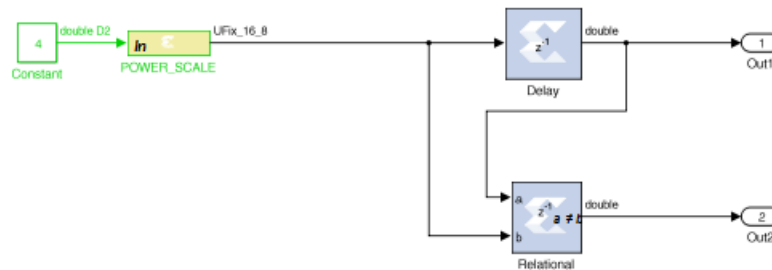



Figure 51: Modified CTRL Subsystem

This will create an output strobe on `Out2` which will be active for one cycle when the input changes. This will be used as the write-enable from **CTRL** to the Gain Control (the **FIFO** block at the top level).

13. Click the **Up to Parent** toolbar button  to return to the top level.
14. Double-click the instance **Gain Control** to open the subsystem.
15. Right-click in the canvas and use **Xilinx BlockAdd** to add these blocks:
 - a. Inverter
 - b. Inverter (for a total of two inverters)
 - c. Delay (Xilinx)
16. Select the instance **Out1** and make a copy **Out3** (use Ctrl-C and Ctrl-V to cut and paste).
 - a. Rename **Out3** to `DDC_Read`
17. Select instance **Out1** and make a copy **Out3** (use Ctrl-C and Ctrl-V to cut and paste).
 - a. Rename **Out3** to `CTRL_Read`

18. Select instance **In1** and make a copy **In4** (use Ctrl-C and Ctrl-V to cut and paste).

a. Rename **In4** to CTRL_Empty

19. Connect the blocks as shown in the following figure.

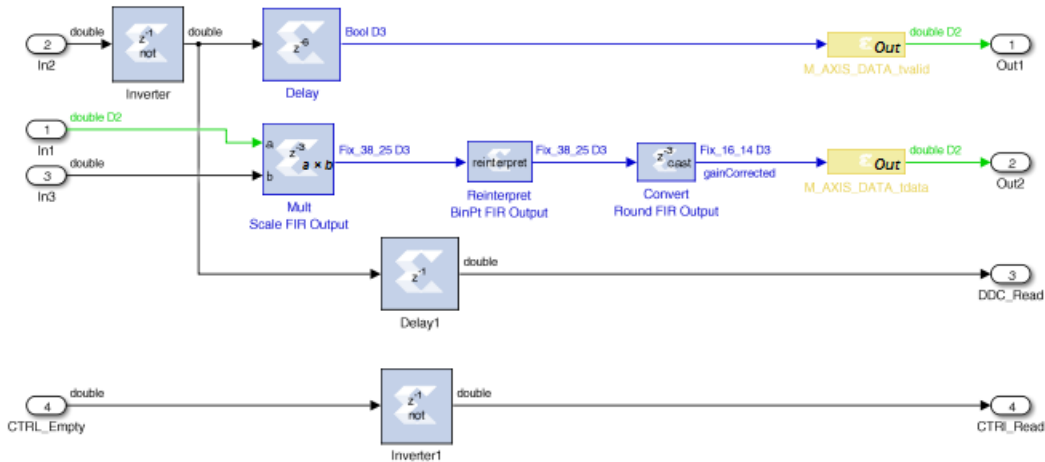



Figure 52: Modified Gain Control Subsystem

- The FIFO empty signal from the top-level Gain Control FIFO (**FIFO**) block is simply an inverter block used to create a read-enable for the top-level DDC FIFO (**FIFO1**). If the FIFO is not empty, the data will be read.
- Similarly, the FIFO empty signal from the top-level DDC FIFO (**FIFO1**) is inverted to create a **FIFO** read-enable.
- This same signal will be used as the new data_tvalid (which was In2). However, since the FIFO has a latency of 1, this signal must be delayed to ensure this control signal is correctly aligned with the data (which is now delayed by 1 through the FIFO).

20. Use the **Up to Parent** toolbar button  to return to the top level.

This shows the control signals are now present at the top level.

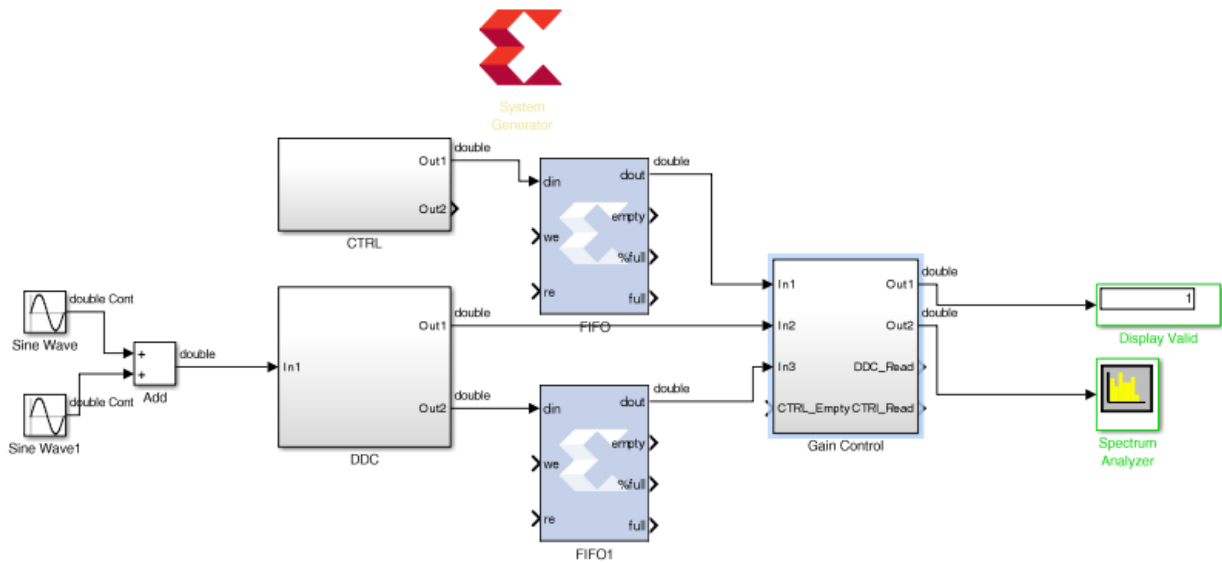

Figure 53: Modified Lab3_1 Design

You will now complete the final connections.

21. Connect the control path through instance **FIFO**. Delete any existing connections to complete this task.
 - a. Connect CTRL/Out2 to FIFO/we.
 - b. Connect FIFO/empty to Gain Control/CTRL_Empty.
 - c. Connect Gain Control/CTRL_Read to FIFO/re.
22. Connect the control path through instance **FIFO1**. Delete any existing connections to complete this task.
 - a. Connect DDC/Out1 to FIFO1/we.
 - b. Connect FIFO1/empty to Gain Control/In2.
 - c. Connect Gain Control/DDC_Read to FIFO1/re.

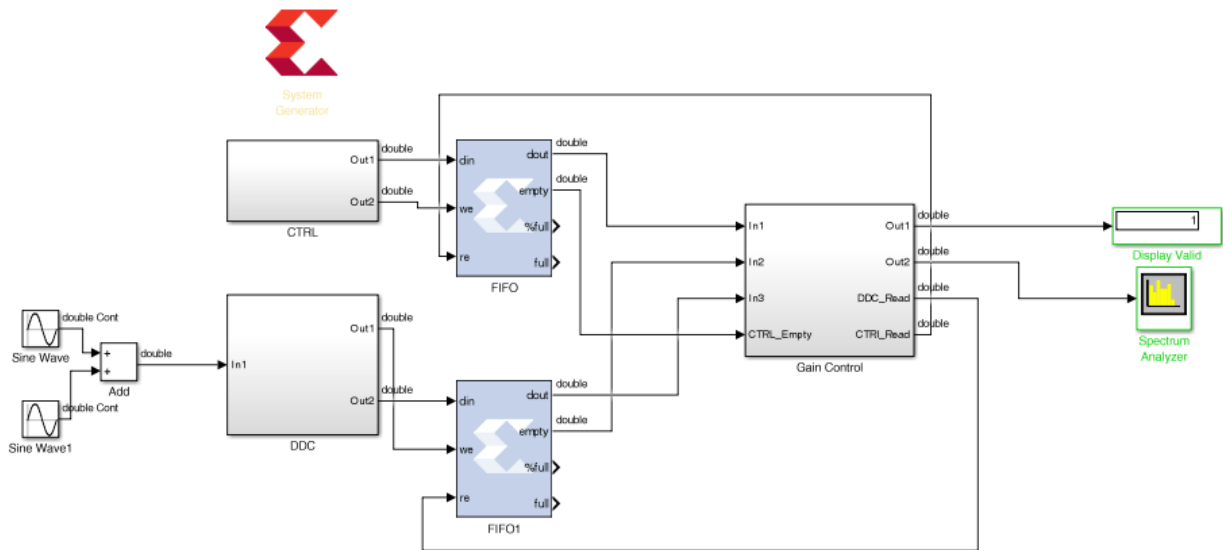

Figure 54: Final Lab3_1 Design

23. Click the **Run** simulation button to simulate the design and confirm the correct operation – you will see the same results as Step 1 action 4).

In the next step, you will learn how to specify different clock domains are associated with each hierarchy.

Step 3: Specifying Clock Domains

In this step you will specify a different clock domain for each subsystem.

1. Double-click the **System Generator** token to open the Properties Editor.
2. Select the **Clocking** tab.
3. Click **Enable multiple clocks**.

Note that the **FPGA clock period** and the **Simulink system period** are now greyed out. This option informs System Generator that clock rate will be specified separately for each hierarchy. It is therefore important the top level contains only subsystems and FIFOs; no other logic should be present at the top level in a multi-rate design.

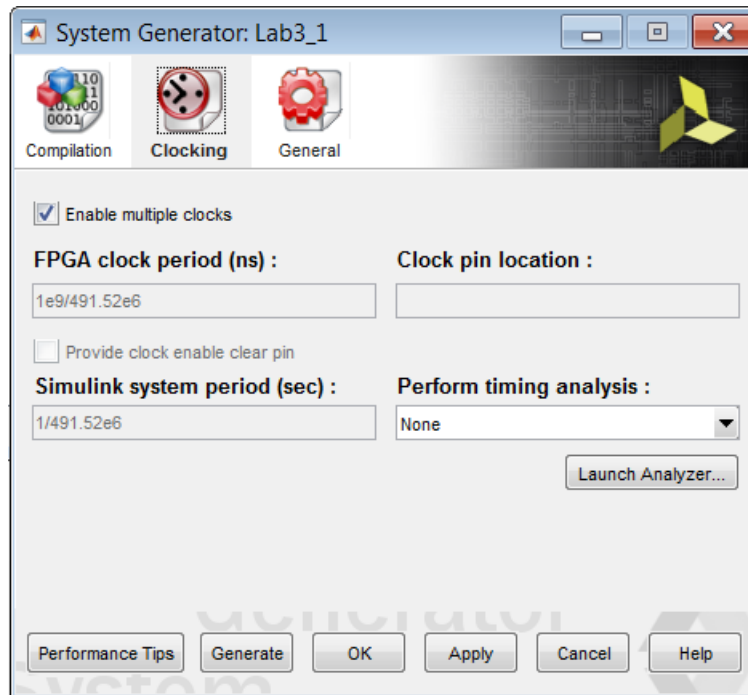

Figure 55: Enable Multiple Clock Domains

4. Click **OK** to close the Properties Editor.

You will now specify a new clock rate for the **CTRL** block. The **CTRL** block will be driven from a CPU which executes at 100 MHz.

5. Select the **System Generator** token.
6. Use Ctrl-C or right-click to copy the token.

You will specify a new clock rate for the **CTRL** block. This block will be clocked at 100 Mhz and accessed using an AXI4-Lite interface.

7. Double-click the **CTRL** block to navigate into the subsystem.
8. Use Ctrl-V or right-click to paste a **System Generator** token into CTRL.
9. Double-click the **System Generator** token to open the Properties Editor.
10. Select the **Clocking** tab.
11. Deselect **Enable multiple clocks** (this was inherited when the token was copied).
12. Change the **FPGA clock period** to $1e9/100e6$.
13. Change the **Simulink system** period to $1/100e6$.

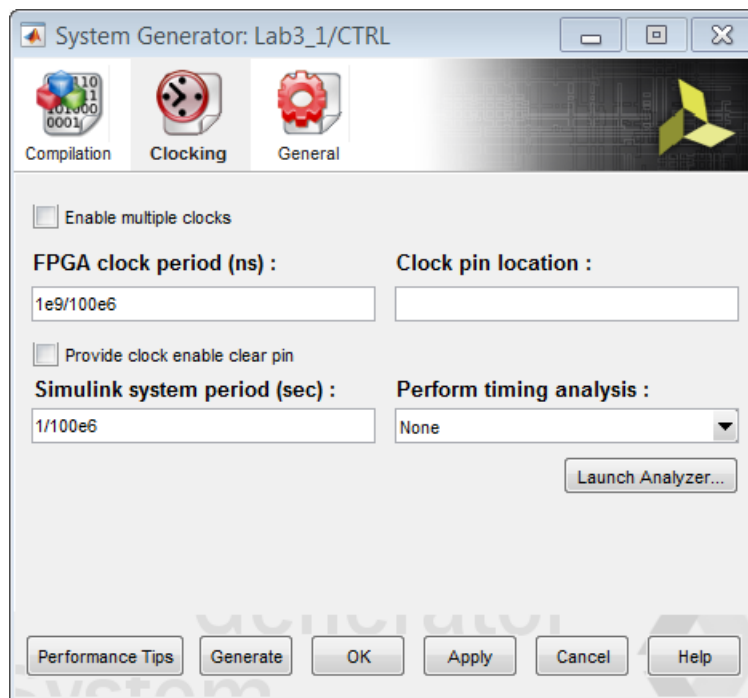

Figure 56: CTRL Clock Domain

14. Click **OK** to close the Properties Editor.
15. Double-click the Gateway In instance **POWER_SCALE** to open the Properties Editor.
16. Change the **Sample period** to 1/100e6 to match the new frequency of this block.

In the **Implementation** tab, note that the Interface is set to AXI4-Lite. This will ensure this port is implemented as a register in an AXI4-Lite interface.

17. Click **OK** to close the Properties Editor.
18. Once again, select and copy the **System Generator** token.
19. Use the **Up to Parent** toolbar button to return to the top level.

You will now specify a new clock rate for the **Gain Control** block. The **Gain Control** block will be clocked at the same rate as the output from the DDC, 61.44 MHz.

20. Double-click the **Gain Control** block to navigate into the subsystem.
21. Use Ctrl-V or right-click to paste a **System Generator** token into **Gain Control**.
22. Double-click the **System Generator** token to open the Properties Editor.
23. Select the **Clocking** tab.
24. Change the **FPGA clock period** to 1e9/61.44e6.
25. Change the **Simulink system period** to 1/61.44e6.

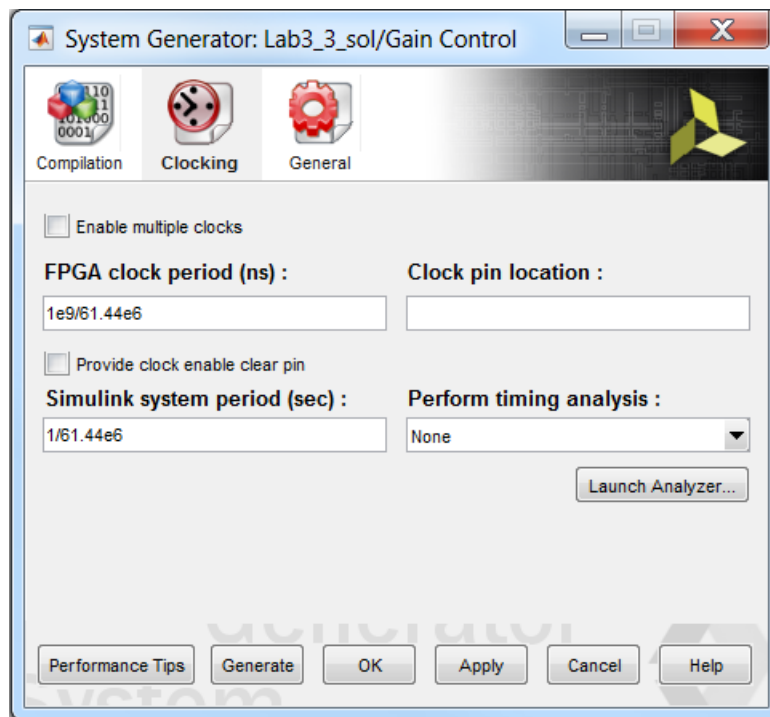

Figure 57: Gain Control Clock Domain

26. Click **OK** to close the Properties Editor.

Note the output signals are prefixed with M_AXI_DATA_. This will ensure that each port will be implemented as an AXI4 interface, since the suffix for both signals is a valid AXI4 signal name (tvalid and tdata).

27. Use the **Up to Parent** toolbar button to return to the top level.

The **DDC** block will use the same clock frequency as the original design, 491 MHz, as this is the rate of the incoming data.

28. In the top-level design, select and copy the **System Generator** token.

29. Double-click the **DDC** block to navigate into the subsystem.

30. Use Ctrl-V or right-click to paste a **System Generator** token into DDC.

31. Double-click the **System Generator** token to open the Properties Editor.

32. Select the **Clocking** tab.

33. Deselect **Enable multiple clocks**. The FPGA clock period and Simulink system period are now set to represent 491 MHz.

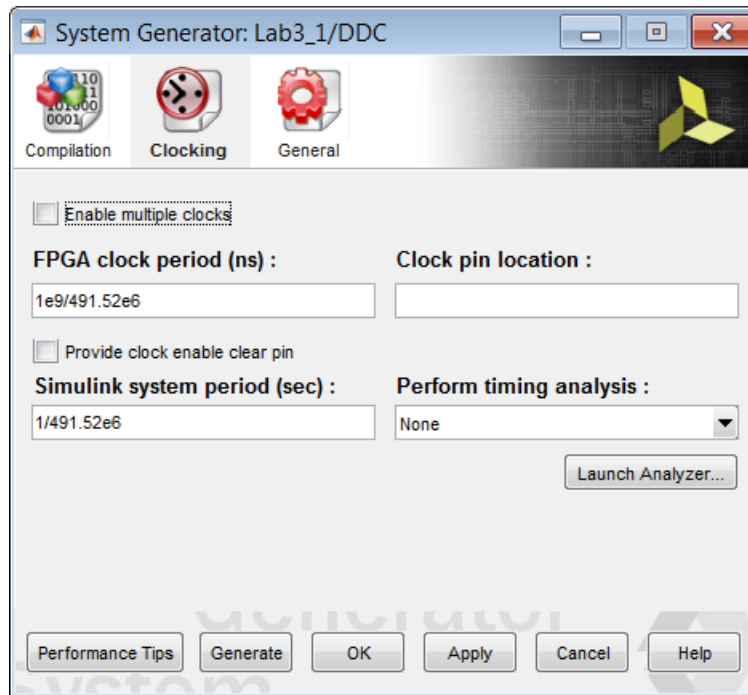

Figure 58: DDC Clock Domain

34. Click **OK** to close the Properties Editor.
35. Use the **Up to Parent** toolbar button to return to the top level.
36. Save the design.
37. Click the **Run** simulation button to simulate the design and confirm the same results as earlier. The design will now be implemented with three clock domains.
38. Double-click the top-level **System Generator** token to open the Properties Editor.
39. Press **Generate** to compile the design into a hardware description.
40. Click **Yes** to dismiss the simulation warning.
41. When generation completes, click **OK** to dismiss the Compilation status dialog box.
42. Click **OK** to dismiss the **System Generator** token.
43. Open the file C:\SysGen_Tutorial\Lab3\IPP_QT_MCD_0001\DDC_HB_hier\ip\hdl\lab3_1.vhd to confirm the design is using three clocks, as shown below.

```
entity lab3_1 is
  port (
    ctrl_clk : in std_logic;
    ddc_clk : in std_logic;
    gain_control_clk : in std_logic;
```

Summary

In this lab, you learned how to create separate hierarchies for portions of the design which are to be implemented with different clock rates. You also learned how to isolate those hierarchies using FIFOs to ensure safe asynchronous transfer of the data and how to specify the clock rates for each hierarchy.

The following solutions directory contains the final System Generator (*.slx) files for this lab. The solutions directory does not contain the IP output from System Generator or the files and directories generated when Vivado is executed.

```
C:/SysGen_Tutorial/Lab3/solution
```

- The results from Step1 are provided in file Lab3_1_sol.slx
- The results from Step2 are provided in file Lab3_2_sol.slx
- The final results from Step3 are provided in file Lab3_3_sol.slx

Lab 4: Working with Workspace Variables

Introduction

In this lab, you will learn how to use workspace variables to easily parameterize your System Generator designs.

Objectives

After completing this lab, you will be able to use workspace variables to create parameterizable and customizable designs.

Procedure

In this lab you will review how a design is parameterized using workspace variables.

Step 1: Using Workspace Variables

In this step you review a design and re-create the design using workspace variables.

1. Invoke System Generator.
 - On Windows systems select **Start > All Programs > Xilinx Design Tools > Vivado 2015.3 > System Generator > System Generator 2015.3**.
 - On Linux Systems, type `sysgen` at the command prompt.
2. Navigate to the Lab4 folder: `cd C:\SysGen_Tutorial\Lab4`.
3. At the command prompt, type `open Lab4_1.slx`

This opens the Simulink design shown in the following figure. In the Simulink Editor menu, select **Display > Signals & Ports > Port Data Types** and you can see the input to the FIR filter is a 16-bit fixed-point data type.

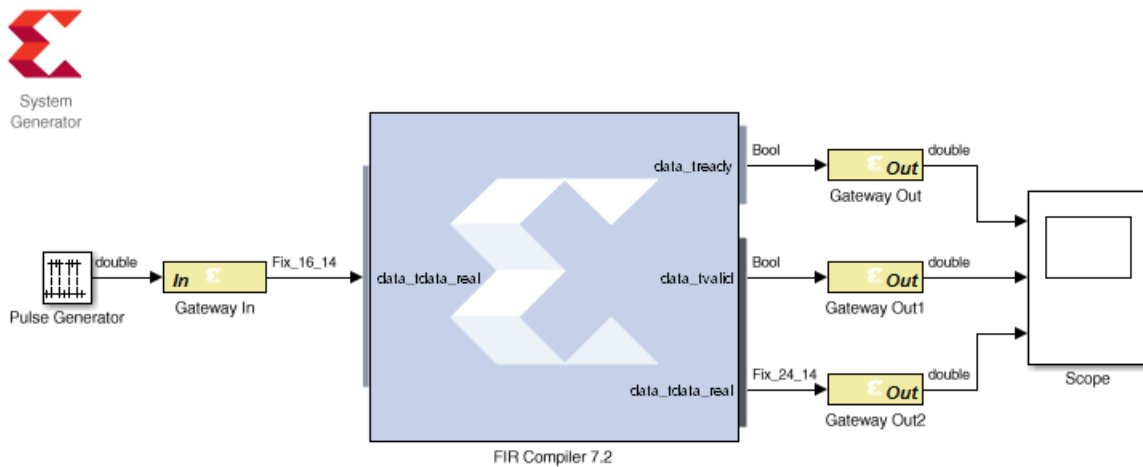

Figure 59: Initial Lab4_1 Design

4. Click the **Run** simulation button to simulate the design.
5. Double-click the Scope to examine the signals.



TIP: You may need to zoom in and select autoscale to view the signals in detail.

In the figure below you can review the output which shows a standard impulse response from the filter. In this case the peak value is approximately 50.

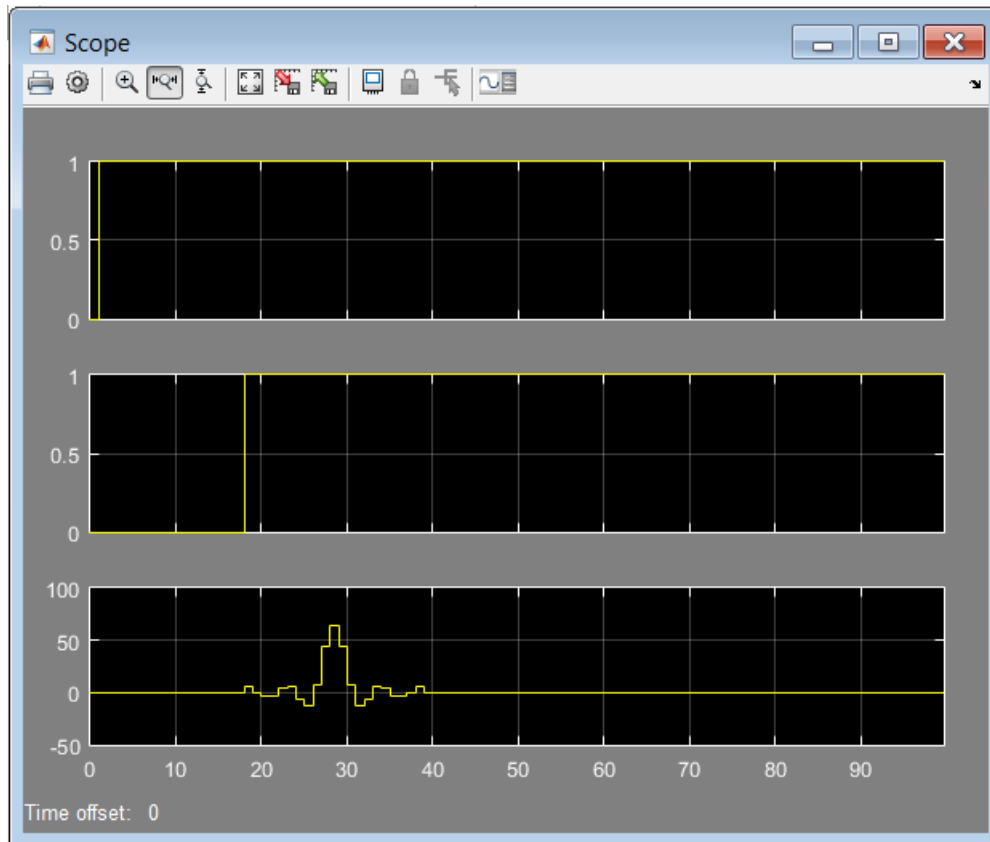

Figure 60: Lab4_1 Initial Scope Results

You will now replace some of the attributes of this design with workspace variables. First, you need to define some workspace variables.

6. In the MATLAB Command Window:
 - a. Type `MyCoeffs = fir1(30, 0.5)`
 - b. Type `num_bits = 24`
 - c. Type `bin_pt = 8`

```

Command Window
>> MyCoeffs = fir1(30, 0.5)

MyCoeffs =

Columns 1 through 6
-0.0017    0.0000    0.0029   -0.0000   -0.0067    0.0000

Columns 7 through 12
 0.0141   -0.0000   -0.0268    0.0000    0.0491   -0.0000

Columns 13 through 18
-0.0969    0.0000    0.3156    0.5008    0.3156    0.0000

Columns 19 through 24
-0.0969   -0.0000    0.0491    0.0000   -0.0268   -0.0000

Columns 25 through 30
 0.0141    0.0000   -0.0067   -0.0000    0.0029    0.0000

Column 31
-0.0017

>> num_bits = 24

num_bits =

    24

>> bin_pt = 8

bin_pt =

     8

fx >> |
    
```

Figure 61: Defining Workspace Variables

7. In design Lab4_1, double-click the **Gateway In** block to open the Properties Editor.
8. In the Fixed-Point Precision section, replace 16 with `num_bits` and replace 14 with `bin_pt`, as shown below.

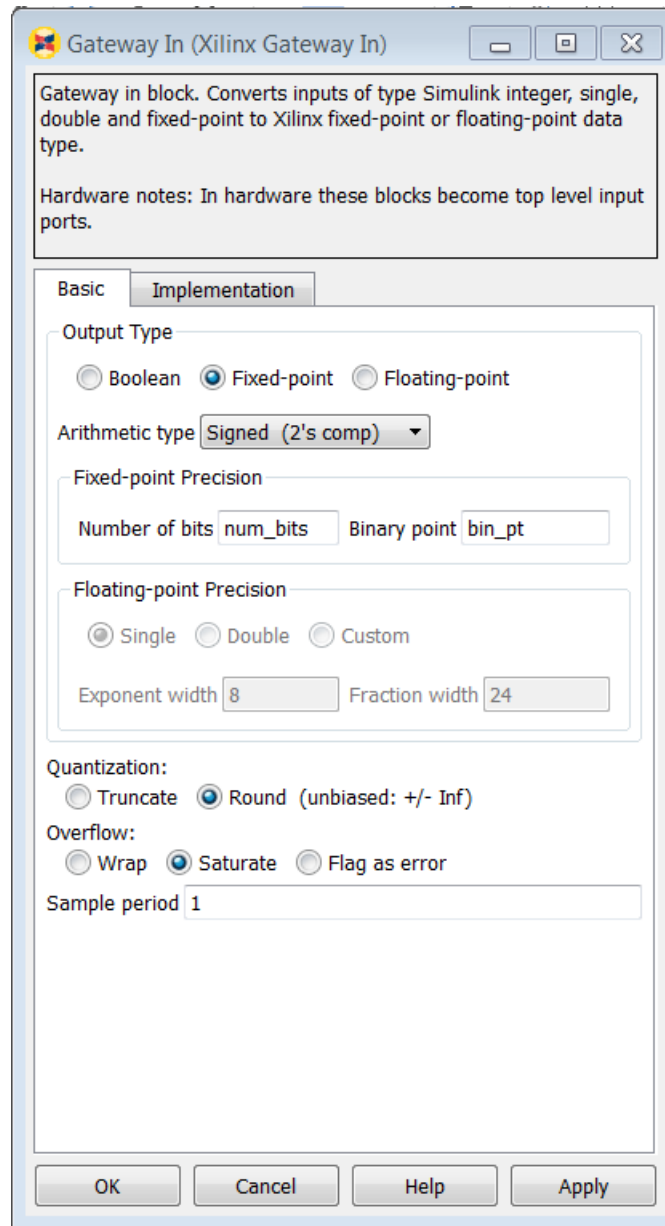

Figure 62: Lab4 Gateway In Properties

9. Click **OK** to save and exit the Properties Editor.
10. Double-click the instance **FIR Compiler 7.2**.
11. In the **Filter Specification** tab, replace the coefficients (**Coefficient Vector**) with `MyCoeffs` as shown below.

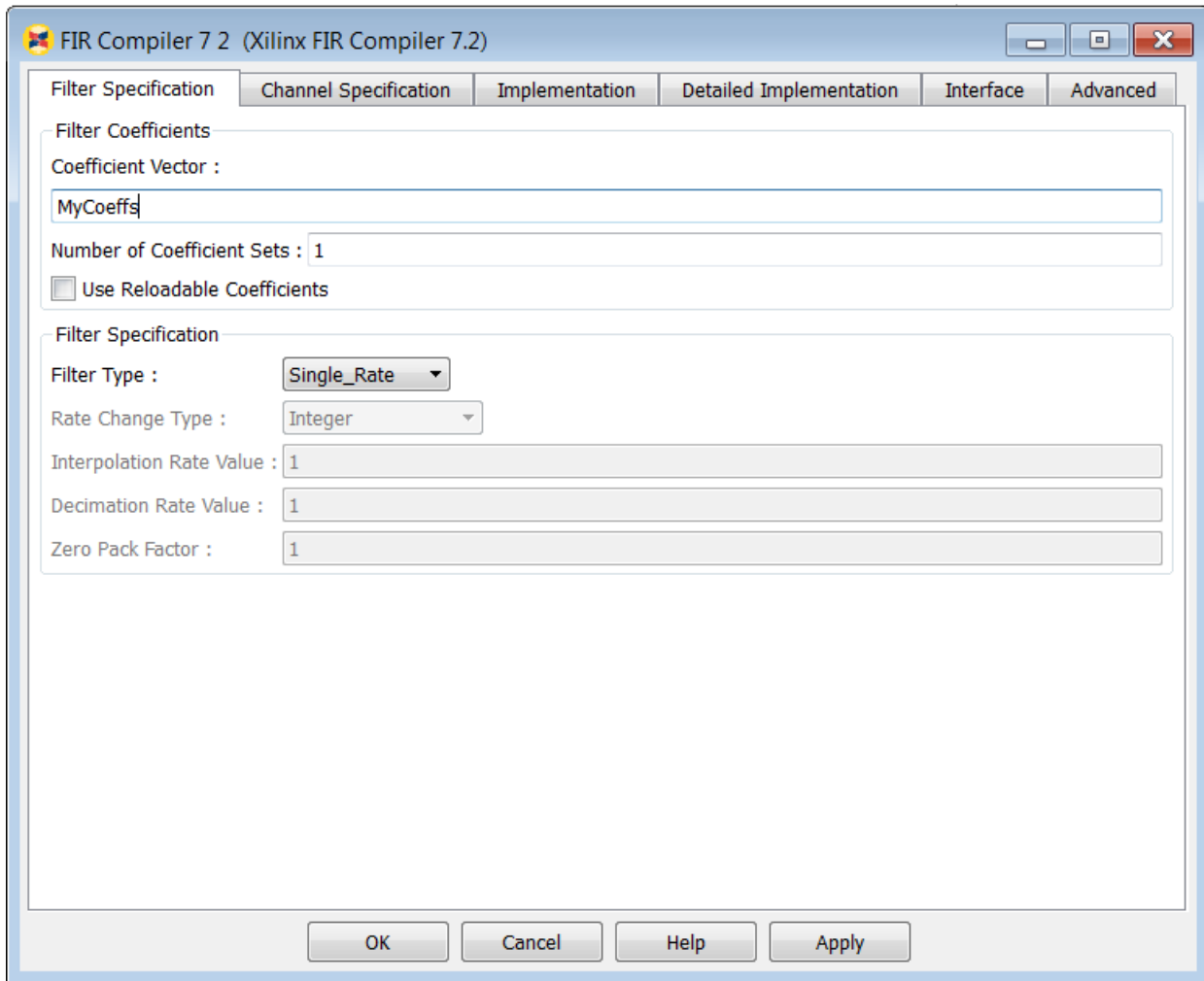

Figure 63: FIR Compiler Properties Editor

12. In the **Implementation** tab of the Properties Editor, use the **Quantization** drop-down menu to select **Maximize_Dynamic_Range**.
13. Click **OK** to save and exit the Properties Editor.
14. Save the design.
15. Press the **Run** simulation button to simulate the design.

When simulation completes, note the input to the FIR is now a 24-bit fixed-point data type. This is now defined by the workspace variables `num_bits` and `bin_pt` and can now be easily updated directly from the MATLAB console or from a script executed in the console.

16. Double-click the Scope to examine the signals.



TIP: You may need to zoom in and select autoscale to view the signals in detail.

The impulse response is now defined by the values on `MyCoeffs` and only has a peak value of approximately 0.5.

17. In the Lab4_1 design use **File > Close > Close Model** to exit the Lab4_1 design.

18. In the MATLAB console type `bdclose all`.

19. In the MATLAB console type `clear` to remove the variables from the workspace.

20. At the command prompt, type `open Lab4_1.slx`

21. Click the **Run** simulation button to simulate the design.

This results in a numbers of errors since the workspace variables are no longer defined.

22. Exit the `Lab4_1.slx` Simulink worksheet.

Summary

In this lab, you learned how to use workspace variables to enhance your overall efficiency when using System Generator.

Solutions to this lab can be found in the following location:

```
C:/SysGen_Tutorial/Lab4/solution
```

Lab 5: Modeling Control with M-Code

Introduction

In this lab you will be creating a simple Finite State Machine (FSM) using the MCode block to detect a sequence of binary values 1011. The FSM needs to be able to detect multiple transmissions as well, such as 10111011.

Objectives

After completing this lab, you will be able to create a Finite State Machine using the MCode block in System Generator.

Procedure

In this lab you will create the control logic for a Finite State Machine using M-code. You will then simulate the final design to confirm the correct operation.

Step 1: Designing Padding Logic

1. Launch System Generator and change the working directory to:

`C:\SysGen_Tutorial\Lab5`

2. Open the file `Lab5_1.slx`.

You will see the following incomplete diagram.

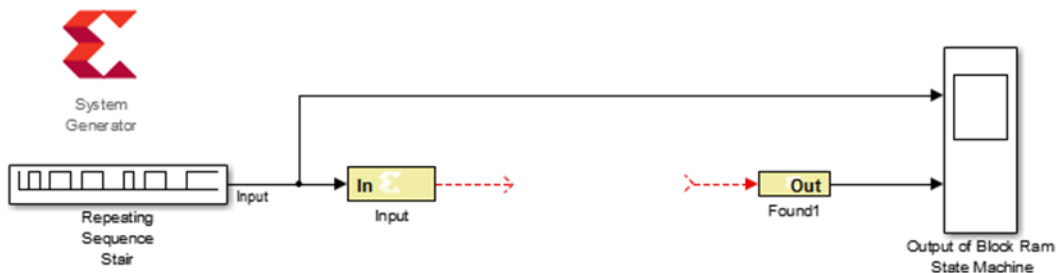

Figure 64: System Generator Block

3. Add an **MCode** block from the Xilinx Blockset/Index library.
 - a. Do not wire up the block yet.
 - b. You will first edit the MATLAB function to create the correct ports and function name.
4. Double-click the **MCode** block and click **Edit M-File**, as shown in the following figure.

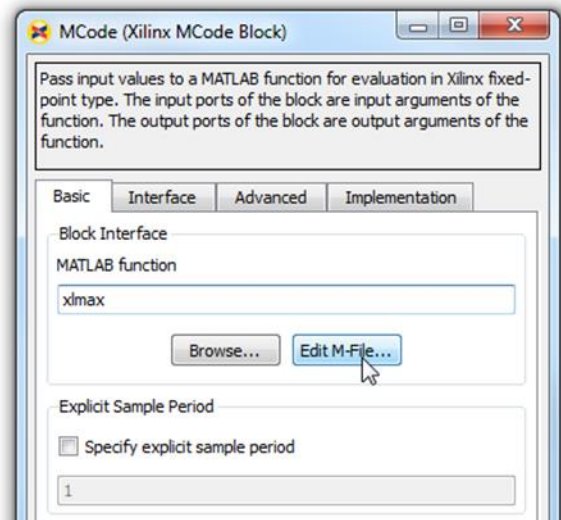

Figure 65: Edit M-File Option

5. Edit the default MATLAB function to include the function name `state_machine` and the input `din` and output `matched`.
6. You can now delete the sample M-code.

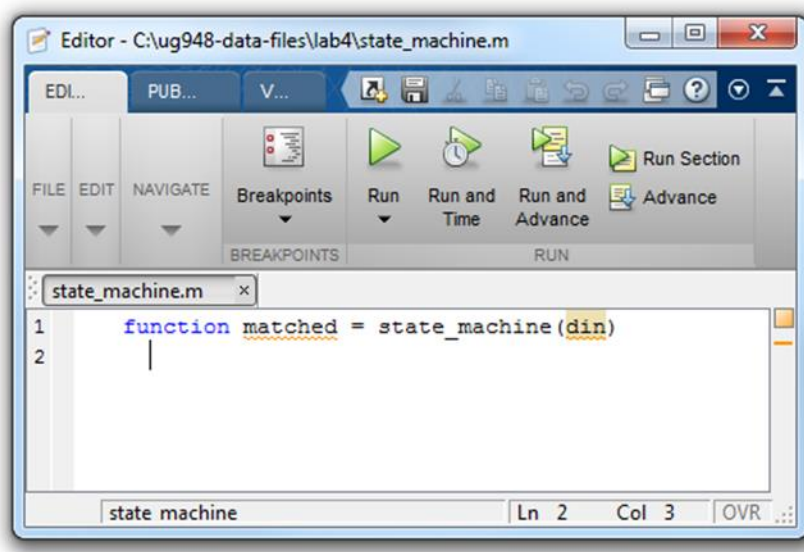

Figure 66: Initial State Machine Code

7. After you make the edits, save the MATLAB file as `state_machine.m` to the Lab5 folder.
 - a. In the MCode Properties Editor, use the **Browse** button to ensure that the **MCode** block is referencing the local M-code file (`state_machine.m`).
8. In the MCode Properties Editor, click **OK**.
 You will see the **MCode** block assume the new ports and function name.
9. Now connect the **MCode** block to the diagram as shown below:

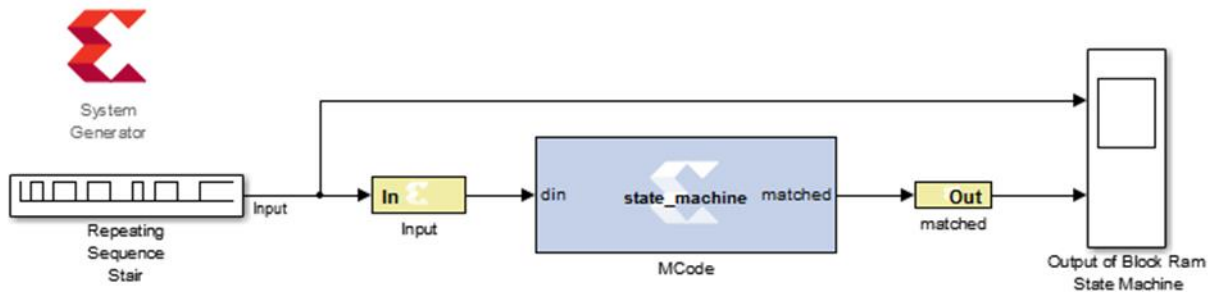

Figure 67: Connected MCode Block

You are now ready to start coding the state machine. The bubble diagram for this state machine is shown in the following figure. This FSM has five states and is capable of detecting two sequences in succession.

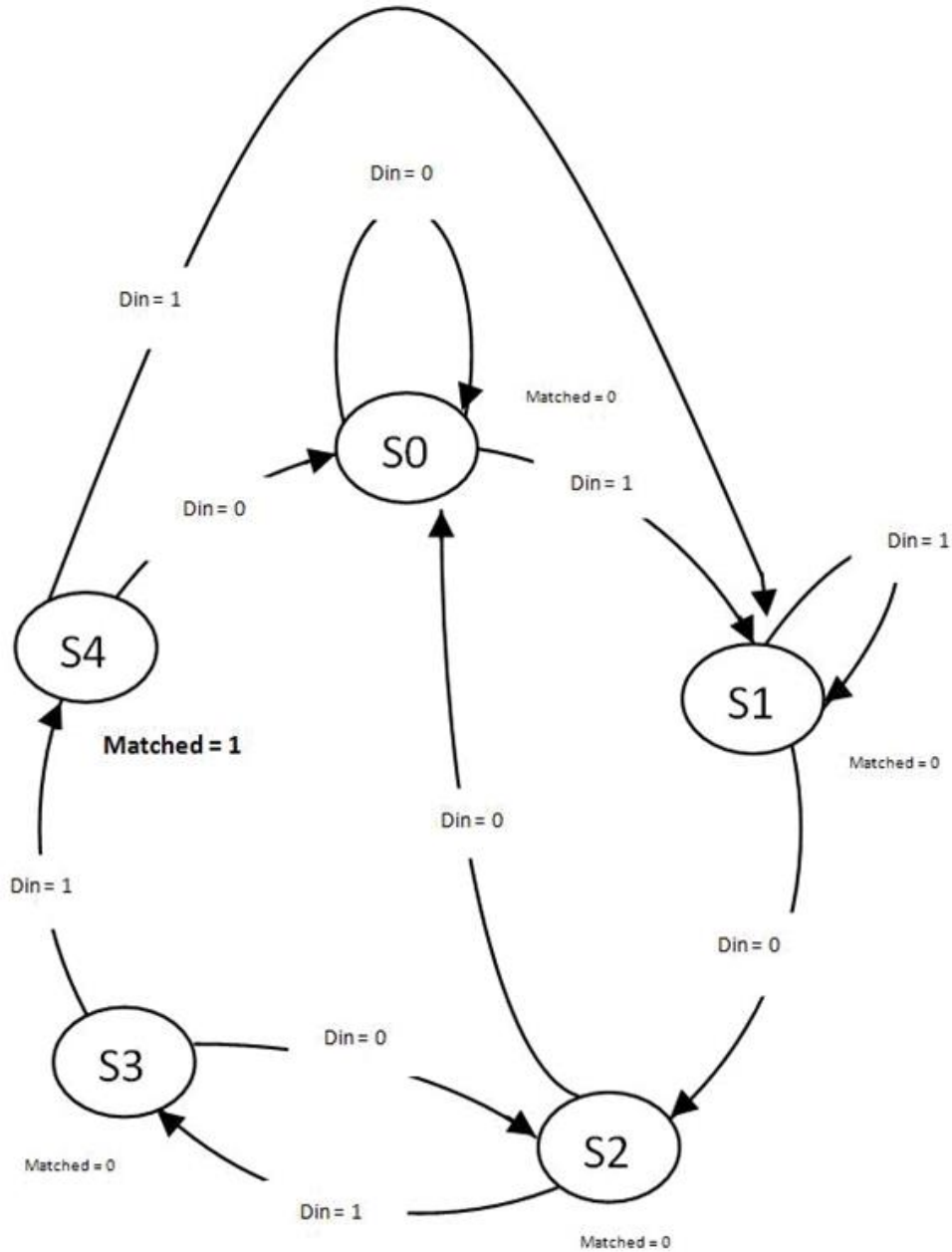

Figure 68: State Machine

10. Edit the M-code file, `state_machine.m`, and define the state variable using the Xilinx `x1_state` data type as shown below. This requires that you declare a variable as a persistent variable. The `x1_state` function requires two arguments: the initial condition and a fixed-point declaration.

Because you need to count up to 4, you need 3 bits.

```
persistent state, state = x1_state(0, {x1Unsigned, 3, 0});
```

11. Use a switch-case statement to define the FSM states shown. A small sample is provided below to get you started.

Note: You need an otherwise statement as your last case.

```
switch state
  case 0
    if din == 1
      state = 1;
    else
      state = 0;
    end
  matched = 0;
```

12. Save the M-code file and run the simulation. The waveform should look like the following figure. You should notice two detections of the sequence.

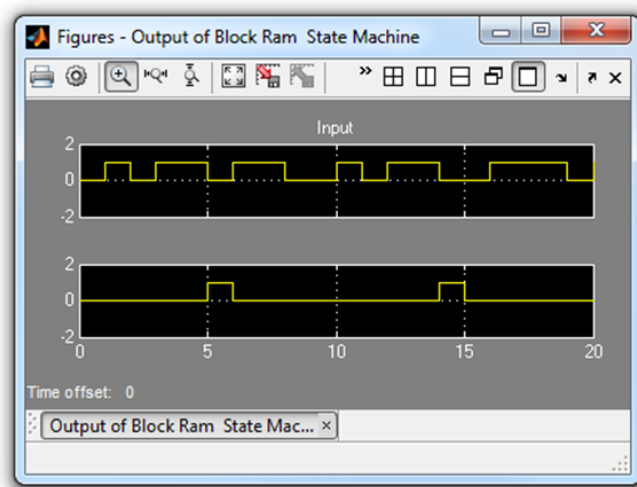

Figure 69: Lab5 Waveforms

Summary

In this exercise you learned how to create control logic using M-Code. The final design may be used to create an HDL netlist, in the same manner as designs created using the Xilinx Blocksets.

Solutions to this lab can be found in the following location:

```
C:/SysGen_Tutorial/Lab5/solution
```

Lab 6: Modeling Blocks with HDL

Lab 6 Introduction

In this lab exercise you will import an RTL design into System Generator as a black box.

- A black box allows the design to be imported into System Generator even though the description is in Hardware Description Language (HDL) format.

Objectives

After completing this lab, you will be able to:

- Import an RTL HDL description into System Generator for DSP.
- Configure the black box to ensure the design can be successfully simulated.

Step 1: Import RTL as a Black Box

1. Invoke System Generator and from the MATLAB console, change the directory to:
`C:\SysGen_Tutorial\Lab6`

The following files are located in this directory:

- `Lab6_1.slx` - A Simulink model containing a black box example.
 - `transpose_fir.vhd` - Top-level VHDL for a transpose form FIR filter. This file is the VHDL that is associated with the black box.
 - `mac.vhd` - Multiply and adder component used to build the transpose FIR filter.
2. Type `open Lab6_1.slx`.
 3. Open the subsystem named **Down Converter**.
 4. Open the subsystem named **Transpose FIR Filter Black Box**.

At this point, the subsystem contains two input ports and one output port. You will add a black box to this subsystem:

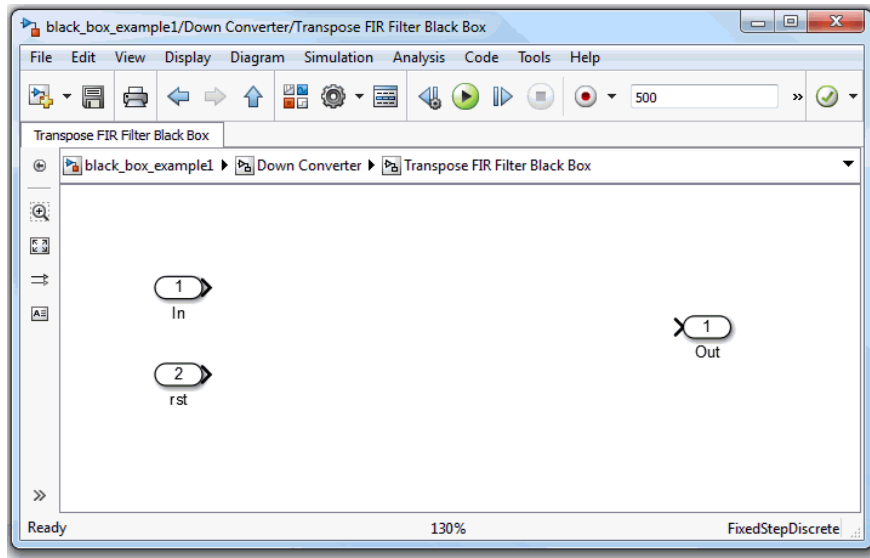

Figure 70: Lab6_1 Design: Transpose FIR Filter Black Box

5. Right-click the design canvas, select **Xilinx BlockAdd**, and add a **Black Box** block to this subsystem. A browser window opens, listing the VHDL source files that can be associated with the black box.
6. From this window, select the top-level VHDL file `transpose_fir.vhd`. This is illustrated in the following figure:

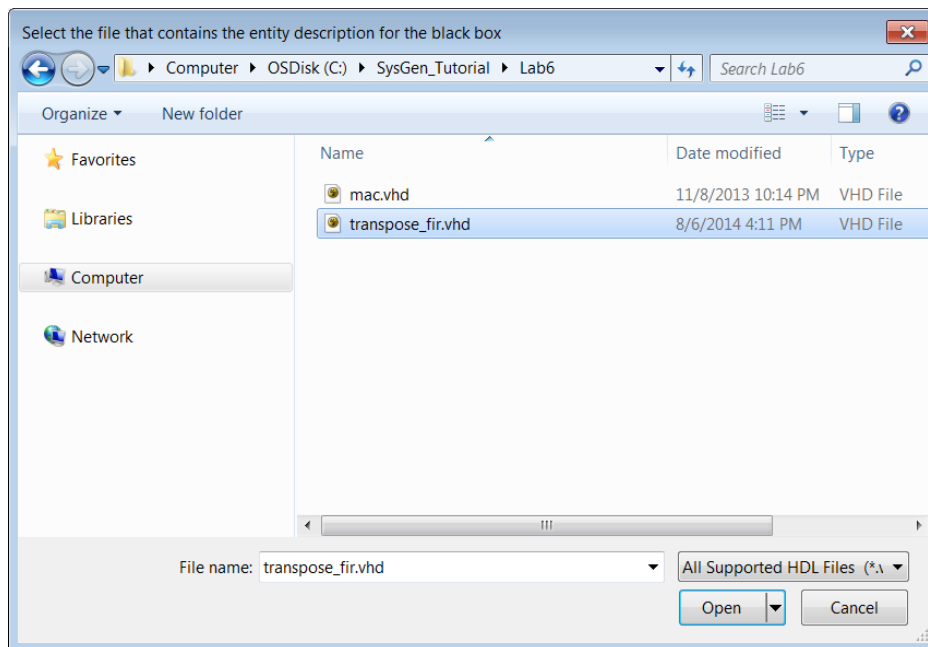

Figure 71: Transpose Filter HDL

The associated configuration M-code `transpose_fir_config.m` opens in an Editor for modifications.

7. Close the Editor.
8. Wire the ports of the black box to the corresponding subsystem ports and save the design.

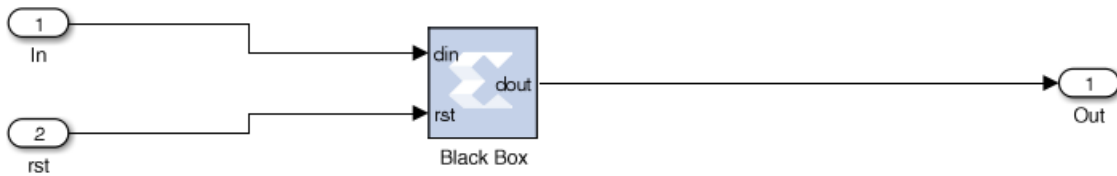

Figure 72: Transpose Filter as a Black Box

9. Double click the **Black Box** block to open this dialog box:

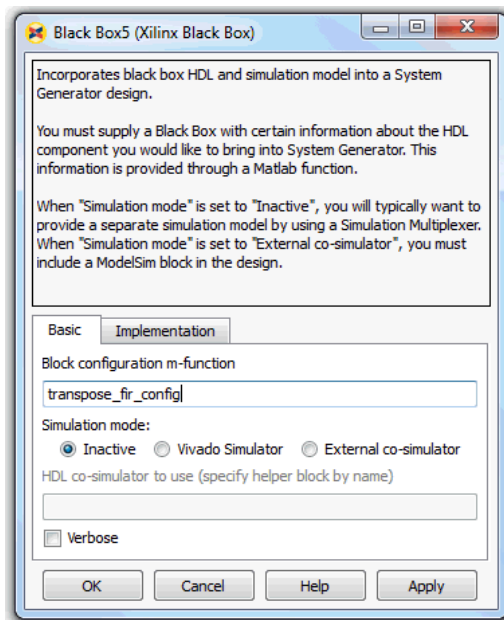



Figure 73: Black Box Properties Editor

The following are the fields in the dialog box:

- **Block configuration m-function:** This specifies the name of the configuration M-function for the black box. In this example, the field contains the name of the function that was generated by the Configuration Wizard. By default, the black box uses the function the wizard produces. You can however substitute one you create yourself.
 - **Simulation mode:** There are three simulation modes:
 - **Inactive:** When the mode is Inactive, the black box participates in the simulation by ignoring its inputs and producing zeros. This setting is typically used when a separate simulation model is available for the black box, and the model is wired in parallel with the black box using a simulation multiplexer.
 - **Vivado Simulator:** When the mode is Vivado Simulator, simulation results for the black box are produced using co-simulation on the HDL associated with the black box.
 - **External co-simulator:** When the mode is External co-simulator, it is necessary to add a ModelSim HDL co-simulation block to the design, and to specify the name of the ModelSim block in the **HDL co-simulator to use** field. In this mode, the black box is simulated using HDL co-simulation.
10. To continue this exercise, leave the parameters set as they currently are (Inactive) and close the dialog box.
11. Move to the design's top level and run the simulation by clicking the **Run** simulation button  ; then double-click the Scope block.
12. Notice the black box output shown in the Output Signal scope is zero. This is expected because the black box is configured to be **Inactive** during simulation.

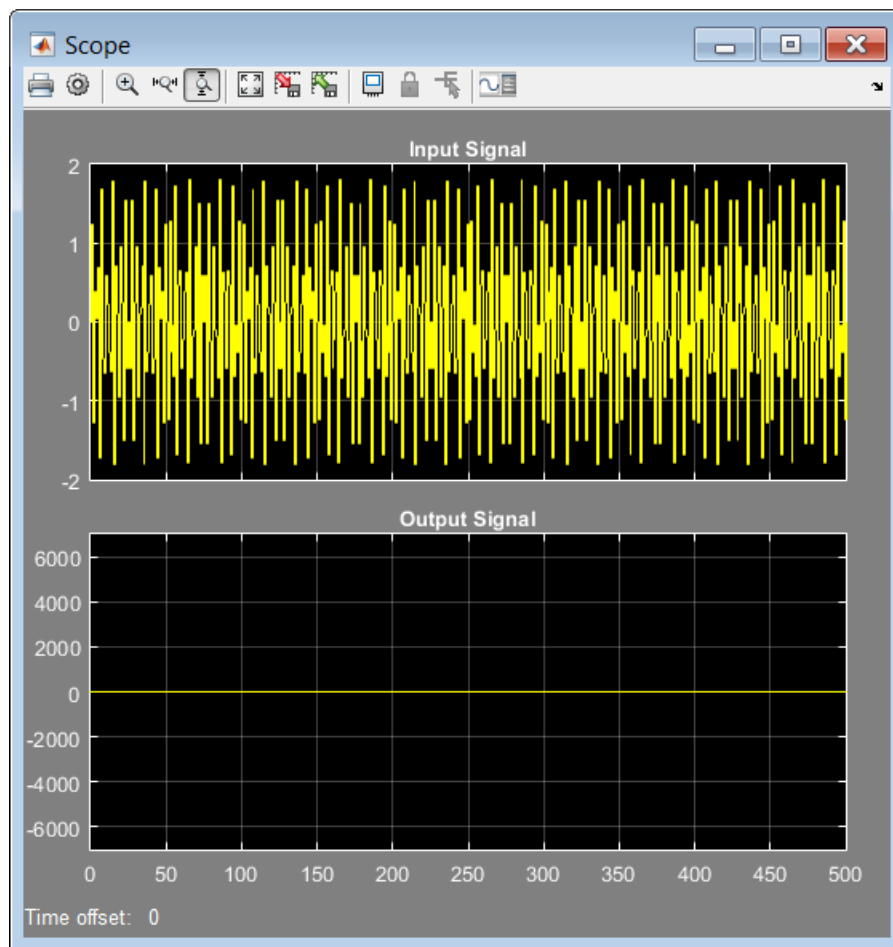

Figure 74: Lab6_1 Scope with Inactive Simulation

13. From the Simulink Editor menu, select **Display > Signals & Ports > Port Data Types** to display the port types for the black box.

14. Compile the model (Ctrl-D) to ensure the port data types are up to date.

Notice that the black box port output type is UFix_26_0. This means it is unsigned, 26-bits wide, and has a binary point 0 positions to the left of the least significant bit.

15. Open the configuration M-function transpose_fir_config.m and change the output type from UFix_26_0 to Fix_26_12. The modified line (line 26) should read:

```
out_port.setType('Fix_26_12');
```

Continue the following steps to edit the configuration M-function to associate an additional HDL file with the black box.

16. Locate line 65: `this_block.addFile('transpose_fir.vhd');`

17. Immediately above this line, add the following: `this_block.addFile('mac.vhd');`

18. Save the changes to the configuration M-function and close the file.
19. Click the design canvas and recompile the model (**Ctrl-D**).

Your **Transpose FIR Filter Black Box** subsystem should display as follows:

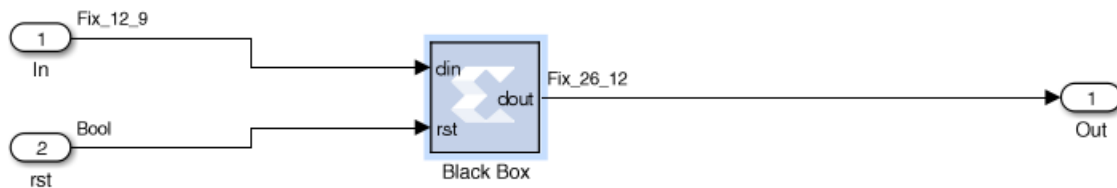

Figure 75: Updated Transpose Filter

20. From the Black Box block parameter dialog box, change the Simulation mode field from **Inactive** to **Vivado Simulator** and then click **OK**.
21. Move to the top-level of the design and run the simulation.
22. Examine the scope output after the simulation has completed.
Notice the waveform is no longer zero. When the Simulation Mode was Inactive, the Output Signal scope displayed constant zero. Now, the Output Signal shows a sine wave as the results from the Vivado Simulation.
23. Right click the Output Signal display and select **Autoscale**. You should see a display similar to that shown below.

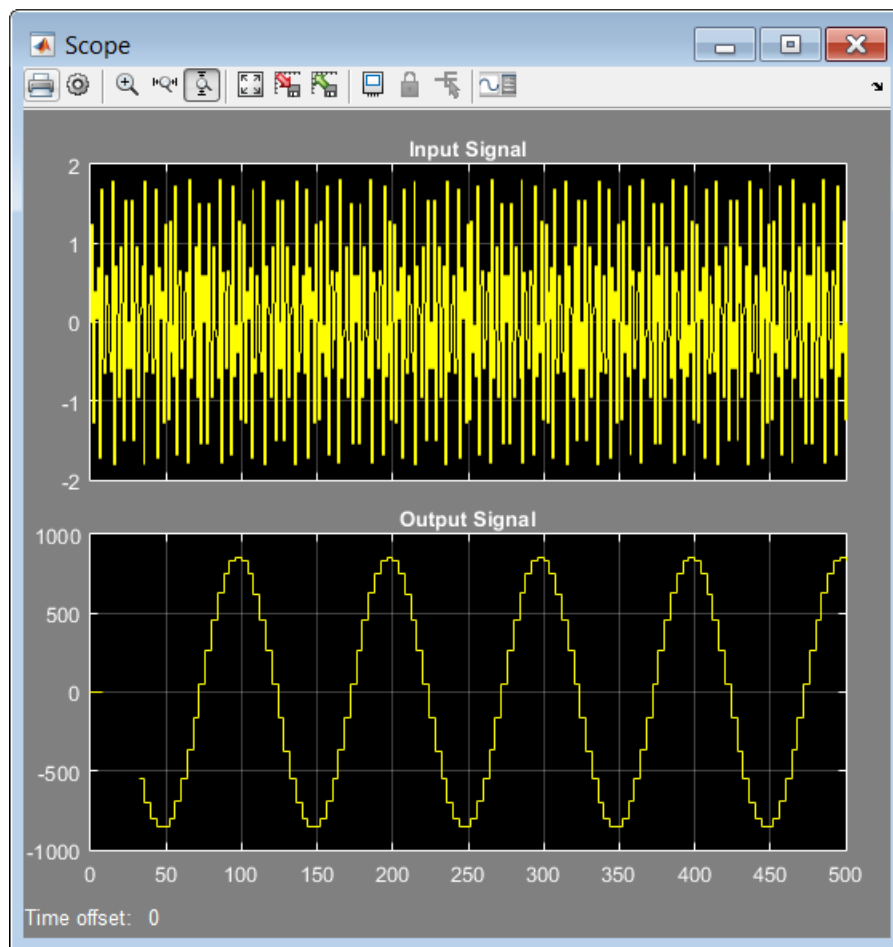

Figure 76: Lab6_1 Scope with Vivado Simulation

Summary

In this exercise you learned how to model blocks in System Generator using HDL by incorporating an existing VHDL RTL design. You learned the importance of matching the data types of the System Generator model with those of the RTL design and how the RTL design is simulated within System Generator.

Solutions to this lab can be found in the following location:

`C:/SysGen_Tutorial/Lab6/solution`

Lab 7: Modeling Blocks with C Code

Lab 7 Introduction

The System Edition of the Vivado® Design Environment includes the Vivado HLS feature, which has the ability to transform C/C++ design sources into RTL. System Generator has a **Vivado HLS** block in the Xilinx Blockset/Control Logic and Xilinx Blockset/Index libraries that enables you to bring in C/C++ source files into a System Generator model.

Objectives

After completing this lab, you will be able to incorporate a design, synthesized from C, C++ or SystemC using Vivado HLS, as a block into your MATLAB design.

Procedure

In this exercise you will first synthesize a C file using Vivado HLS. You will operate within a Vivado DSP design project, using a design file from MATLAB along with an associated HDL wrapper and constraint file. In Step 2, you incorporate the output from Vivado HLS into MATLAB and use the rich simulation features of MATLAB to verify that the C algorithm correctly filters an image.

Step 1: Creating a System Generator Package from Vivado HLS

1. Invoke Vivado HLS: **Start > All Programs > Xilinx Design Tools > Vivado 2015.3 > Vivado HLS > Vivado HLS 2015.3.**
2. Select **Open Project** in the welcome screen and navigate to the Vivado HLS project directory `C:\SysGen_Tutorial\Lab7\hls_project` as shown in the following figure.



Figure 77: Vivado HLS Project

3. Click **OK** to open the project.

- Expand the `Source` folder in the Explorer pane (left-hand side) and double-click the file `MedianFilter.cpp` to view the contents of the C++ file as shown in the following figure.

```

1#include "MedianFilter.h"
2#define WINDOW_SIZE 3
3typedef unsigned char PixelType;
4
5#define PIX_SWAP(a,b) { PixelType temp=(a);(a)=(b);(b)=temp; }
6#define PIX_SORT(a,b) { if ((a)>(b)) PIX_SWAP((a),(b)); }
7
8PixelType OptMedian9(PixelType * p)
9{
10    PIX_SORT(p[1], p[2]) ; PIX_SORT(p[4], p[5]) ; PIX_SORT(p[7], p[8]) ;
11    PIX_SORT(p[0], p[1]) ; PIX_SORT(p[3], p[4]) ; PIX_SORT(p[6], p[7]) ;
12    PIX_SORT(p[1], p[2]) ; PIX_SORT(p[4], p[5]) ; PIX_SORT(p[7], p[8]) ;
13    PIX_SORT(p[0], p[3]) ; PIX_SORT(p[5], p[8]) ; PIX_SORT(p[4], p[7]) ;
14    PIX_SORT(p[3], p[6]) ; PIX_SORT(p[1], p[4]) ; PIX_SORT(p[2], p[5]) ;
15    PIX_SORT(p[4], p[7]) ; PIX_SORT(p[4], p[2]) ; PIX_SORT(p[6], p[4]) ;
16    PIX_SORT(p[4], p[2]) ;
17    return(p[4]) ;
18}
19
20PixelType Mean(PixelType* buffer)
21{

```

Figure 78: C++ Source File

This file implements a 2-Dimensional median filter on 3x3 window size.

- Synthesize the source file by right-clicking on `solution1` and selecting **C Synthesis > Active Solution** as shown in the following figure.

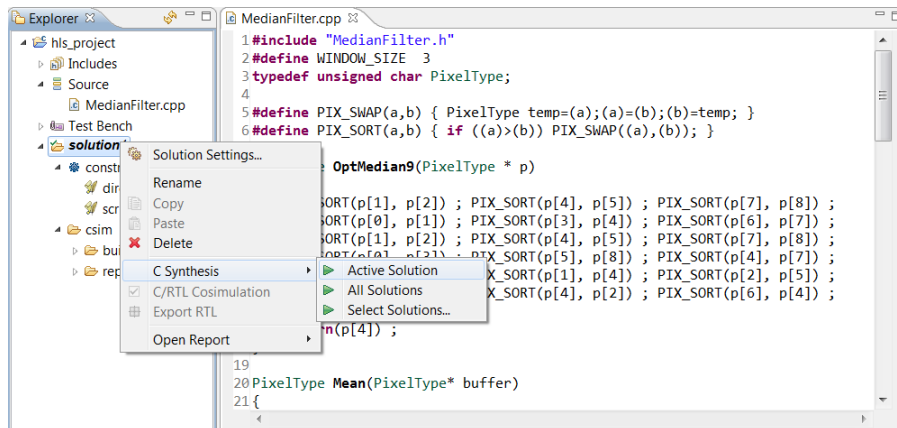

Figure 79: HLS Synthesis

When the synthesis completes, Vivado HLS displays this message:

```
@I [LIC-101] Checked in feature [VIVADO_HLS]
```

Now you will package the source for use in System Generator for DSP.

6. Right click `solution1` and select **Export RTL**.
7. Set Format Selection to **System Generator for DSP** as shown in the following figure and click **OK**.

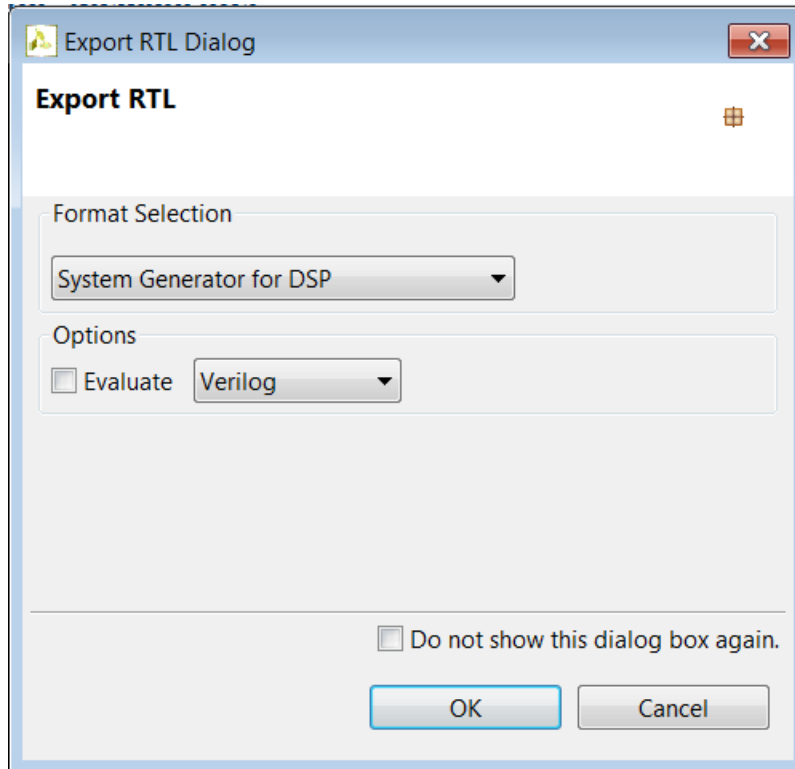

Figure 80: Export HLS IP to System Generator

When the Export RTL process completes, Vivado HLS displays this message:

```
@I [LIC-101] Checked in feature [VIVADO_HLS]
```

8. **Exit** Vivado HLS.

Step 2: Including a Vivado HLS Package in a System Generator Design

1. Launch System Generator and open the `Lab7_1.slx` file in the `Lab7` folder. This should open the model as shown in the following figure.

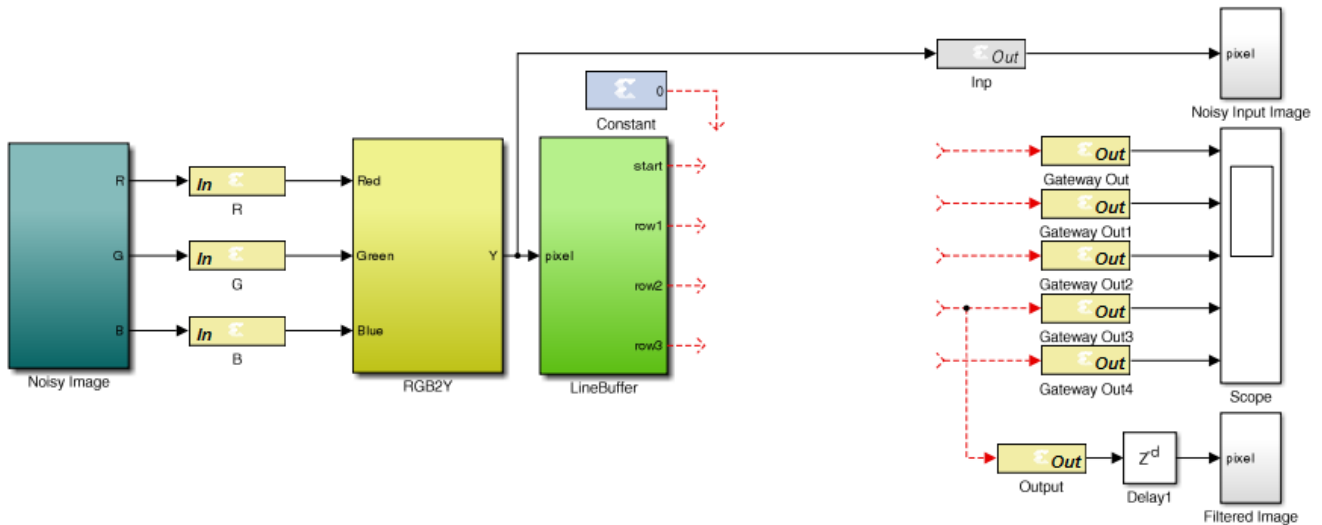

Figure 81: Lab7_1 Design

2. Add a Vivado HLS block by right-clicking anywhere on the canvas workspace.
3. Select **Xilinx BlockAdd**.
4. Type `Vivado HLS` in the Add block dialog box.
5. Select **Vivado HLS** as shown in the figure below.

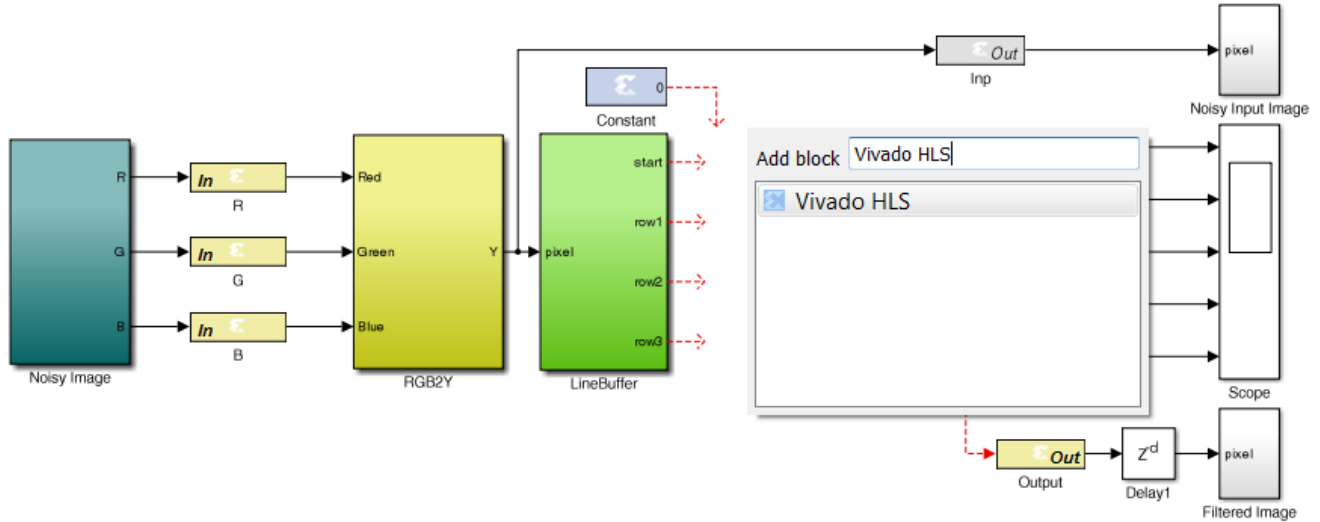

Figure 82: Adding a Vivado HLS Block

6. Double-click the **Vivado HLS** block to open the Properties Editor.
7. Use the **Browse** button to select the solution created by Vivado HLS in Step 1, at `C:/SysGen_Tutorial/Lab7/hls_project/solution1`, as shown in [Figure 83: Importing Vivado HLS IP](#).
8. Click **OK** to import the Vivado HLS IP.

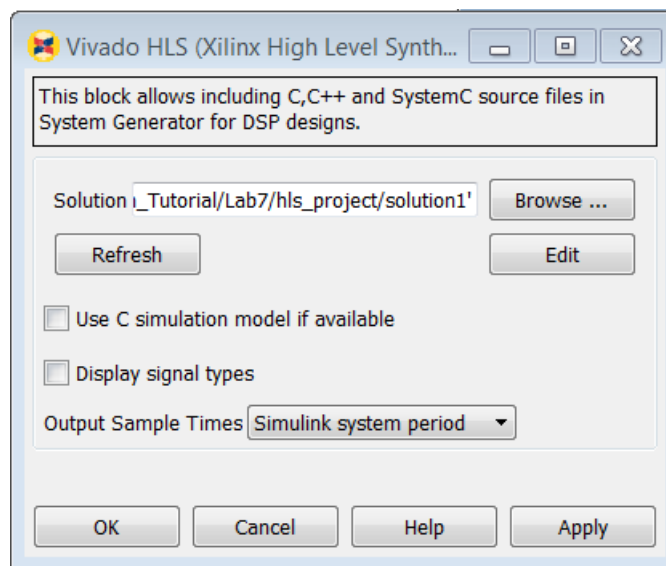

Figure 83: Importing Vivado HLS IP

9. Connect the input and output ports of the block as shown in the following figure.

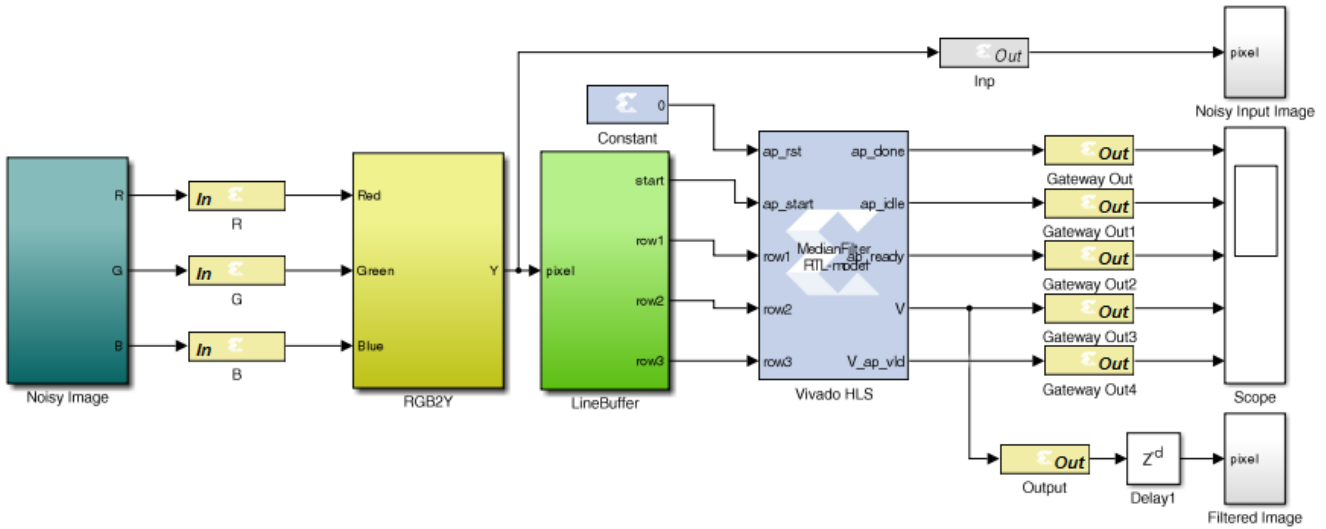

Figure 84: Completed Lab7_1 Design

10. Navigate into the **Noisy Image** sub-system and double-click the **Image From File** block `lena.png` to open the Source Block Parameters dialog box.
11. Use the **Browse** button to ensure the file name correctly point to the file `lena.jpg` as shown below.

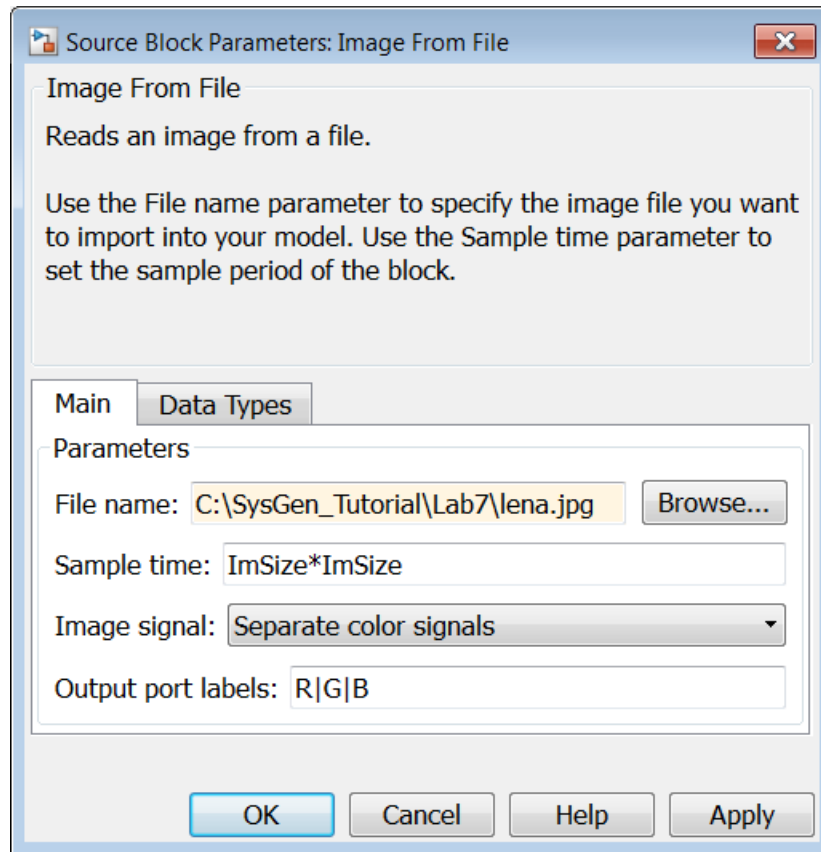



Figure 85: Input Image Location

12. Click **OK** to exit the Source Block Parameters dialog box.
13. Use the toolbar button Up to Parent  to return to the top level.
14. Save the design.
15. **Simulate** the design and verify the image is filtered, as shown in the following figures.

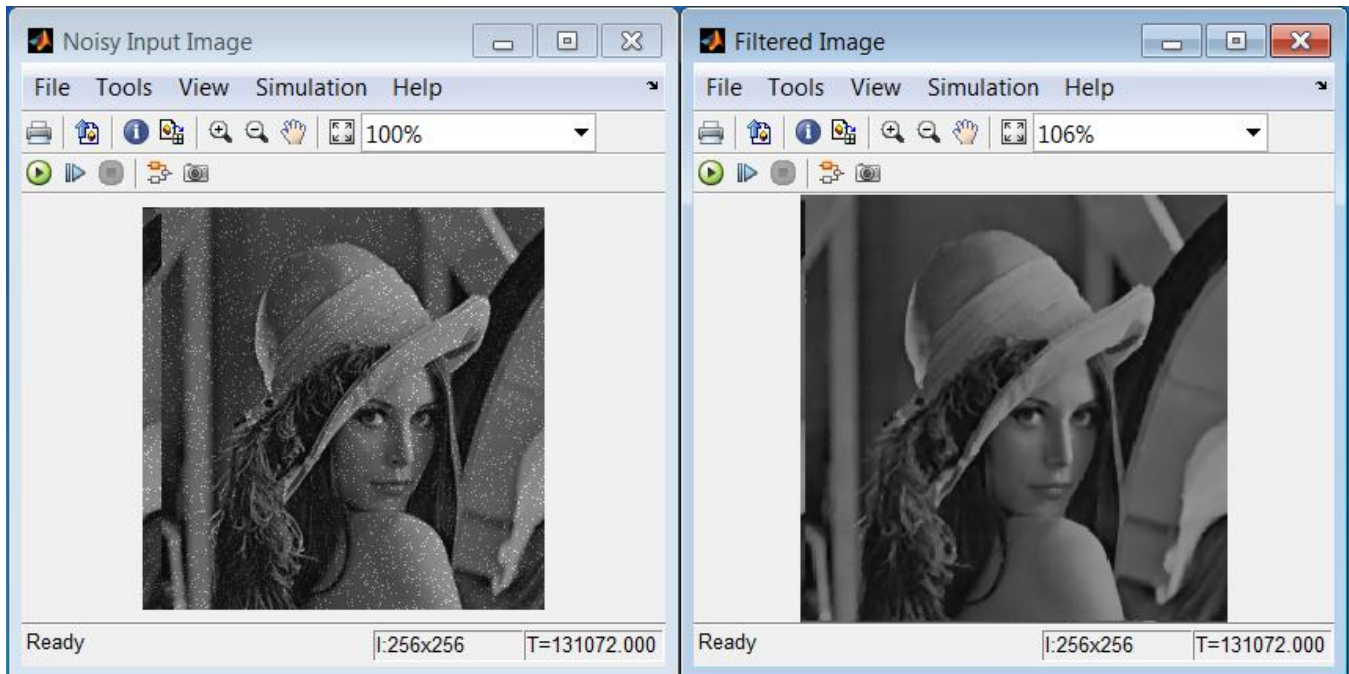

Figure 86: Lab7_1 Simulation Results

Summary

In this lab exercise you were able to take a filter written in C++, synthesize it with Vivado HLS and incorporate the design into MATLAB. This process allows you to use any C, C++ or SystemC design and create a custom block for use in your designs.

This exercise showed you how to import the RTL design generated by Vivado HLS and use the design inside MATLAB.

Solutions to this lab can be found in the following location:

```
C:/SysGen_Tutorial/Lab7/solution
```

Lab 8: Using AXI Interfaces and IP Integrator

Introduction

In this lab, you will learn how AXI interfaces are implemented using System Generator. You will save the design in IP catalog format and use the resulting IP in the Vivado IP Integrator environment. Then you will see how IP Integrator enhances your productivity by supplying connection assistance when you use AXI interfaces.

Objectives

After completing this lab, you will be able to:

- Implement AXI interfaces in your designs.
- Add your design as IP in the Vivado IP Catalog.
- Connect your design in IP Integrator.

Procedure

This exercise has four primary parts.

- In Step 1, you will review how AXI interfaces are implemented using System Generator.
- In Step 2, you will create a Vivado project for your System Generator IP.
- In Step 3, you will create a design in IP Integrator using the System Generator IP.
- In Step 4, you will implement the design and generate an FPGA bitstream (the file used to program the FPGA).

Step 1: Review the AXI Interfaces

In this step you review how AXI interfaces are defined and created.

1. Invoke System Generator and use the **Current Folder** browser to change the directory to `C:\SysGen_Tutorial\Lab8`.
2. Type `Open Lab8_1.slx` in the Command Window.

This opens the design shown in the following figure.

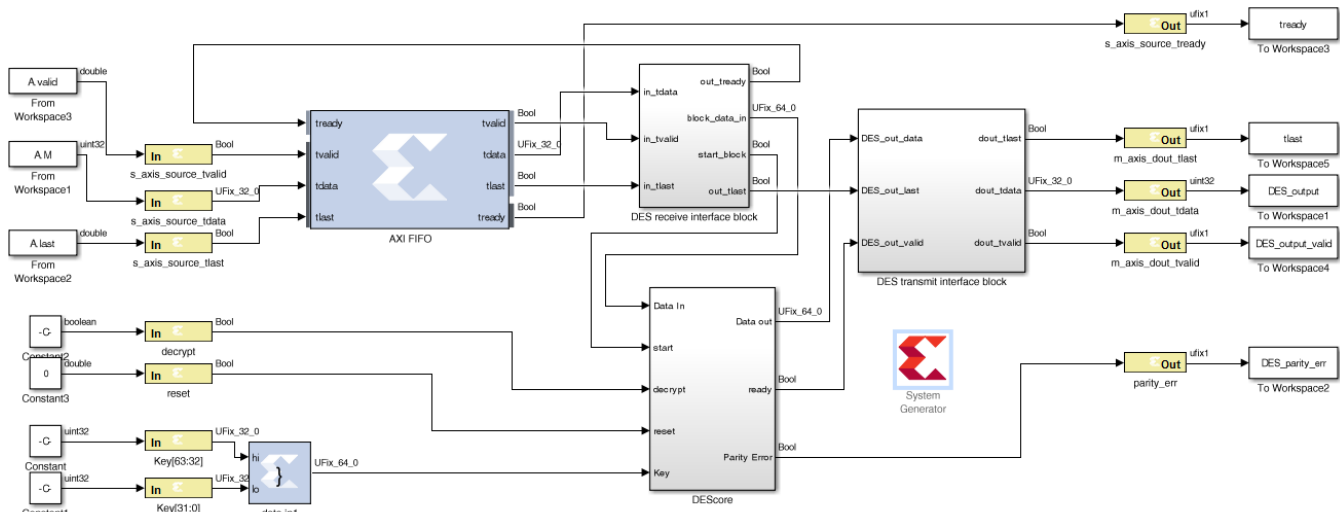

Figure 87: Lab8_1 Design

This design uses a number of AXI interfaces. You will review these shortly.

- Using AXI interfaces allows a design exported to the Vivado IP Catalog to be efficiently integrated into a larger system using IP Integrator.
- It is *not* a requirement for designs exported to the IP Catalog to use AXI interfaces.

This design uses the following AXI interfaces:

- An AXI4-Stream interface is used for ports `s_axis_source_*`. All Gateway In and Out signals are prefixed with the same name (`s_axis_source_*`), ensuring they are grouped into the same interface. The suffixes for all ports are valid AXI4-Stream interface signal names (`tready`, `tvalid`, `tlast` and `tdata`).
- Similarly, an AXI4-Stream interface is used for ports `m_axis_dout_*`.
- An AXI4-Lite interface is used for the remaining ports. You can confirm this using the following steps:

3. Double-click Gateway In instance `decrypt` (or any of `reset`, `Keys [63:32]`, `Keys [31:0]`, `parity_err`).
4. In the Properties Editor select the **Implementation** tab.
5. Confirm the Interface is specified as **AXI4-Lite** in the Interface options.
6. Click **OK** to exit the Properties Editor.

Details on simulating the design are provided in the canvas notes. For this exercise, you will concentrate on exporting the design to the Vivado IP catalog and use the IP in an existing design.

Step 2: Create a Vivado Project using System Generator IP

In this step you create a Vivado project which you will use to create your hardware design.

1. Double-click the **System Generator** token to open the Properties Editor.
2. In the Properties Editor, make sure **IP Catalog** is selected for the **Compilation** type.
3. Click **Generate** to generate a design in IP Catalog format.
4. Click **OK** to dismiss the Compilation status dialog box.
5. Click **OK** to dismiss the **System Generator** token.

The design has been written in IP Catalog format to the directory `./sys_gen_ip`. You will now import this IP into the Vivado IP Catalog and use the IP in an existing example project.

6. Open the Vivado IDE using **Start > All Programs > Xilinx Design Tools > Vivado 2015.3 > Vivado 2015.3**.
7. Click **Create New Project**.
8. Select **Next**.
9. Specify the project location as `C:/SysGen_Tutorial/Lab8/IPI_Project`.



TIP: You will have to manually type `/IPI_Project` in the **Project location** box to create the `IPI_Project` directory.

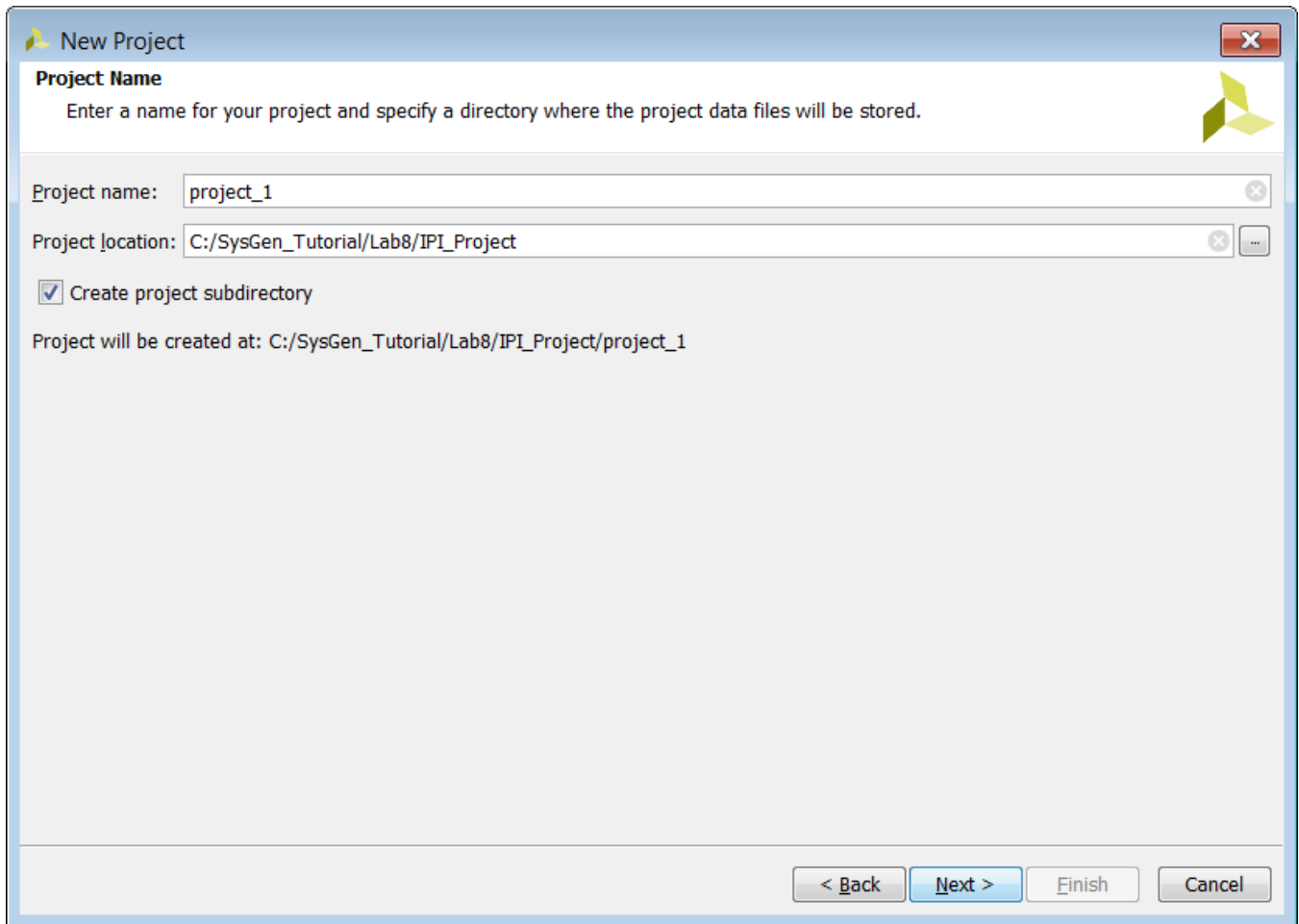

Figure 88: Vivado IPI Project

10. Click **Yes** to create the directory IPI_Project
11. Click **Next**.
12. Select both **RTL Project** and **Do not specify sources at this time** and click **Next**.
13. Select **Boards** and **ZYNQ-7 ZC702 Evaluation Board** as shown in the next figure.

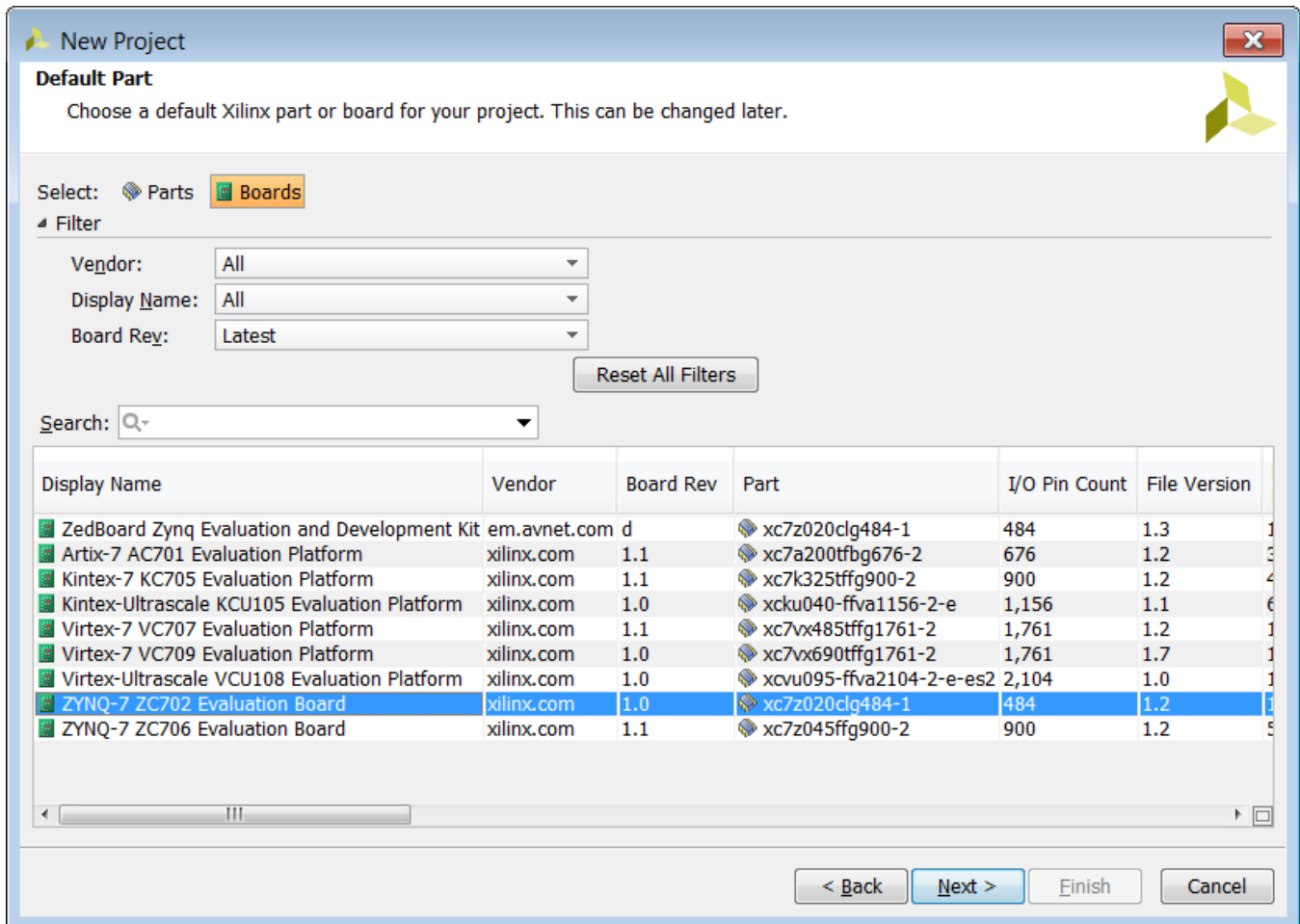

Figure 89: Target Device

14. Click **Next**.
15. Click **Finish**.

You have now created a Vivado project based on the ZC702 evaluation board.

Step 3: Create a Design in IPI

In this step you will create a design using the System Generator IP.

1. Click **Create Block Design** in the Flow Navigator pane.

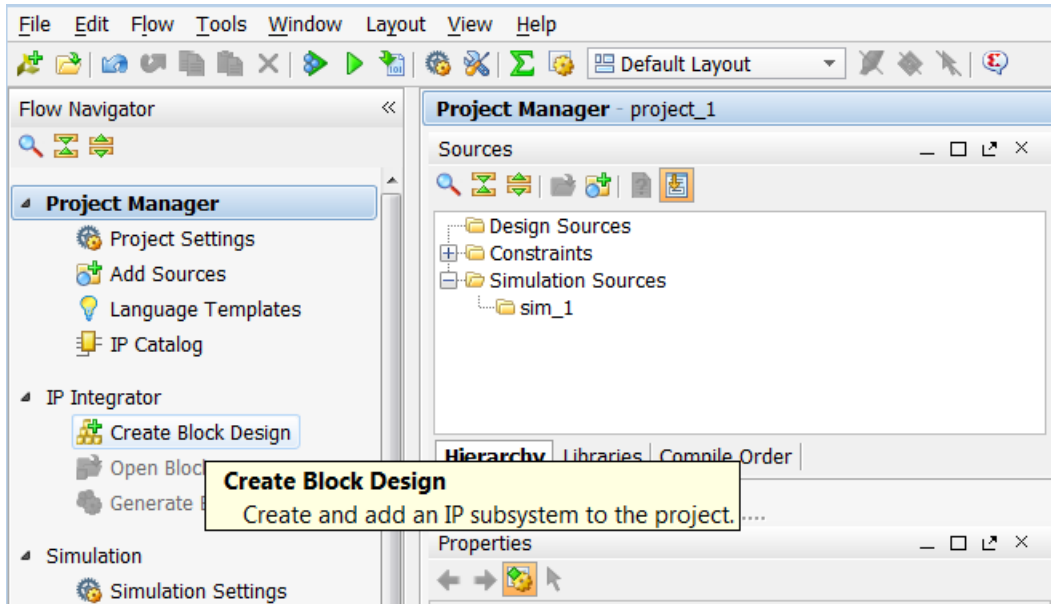

Figure 90: Open Block Design

2. In the Create Block Design dialog box, click **OK** to accept the default name.
You will first create an IP repository for the System Generator IP and add the IP to the repository.
3. Click the **IP Setting** button as shown below.

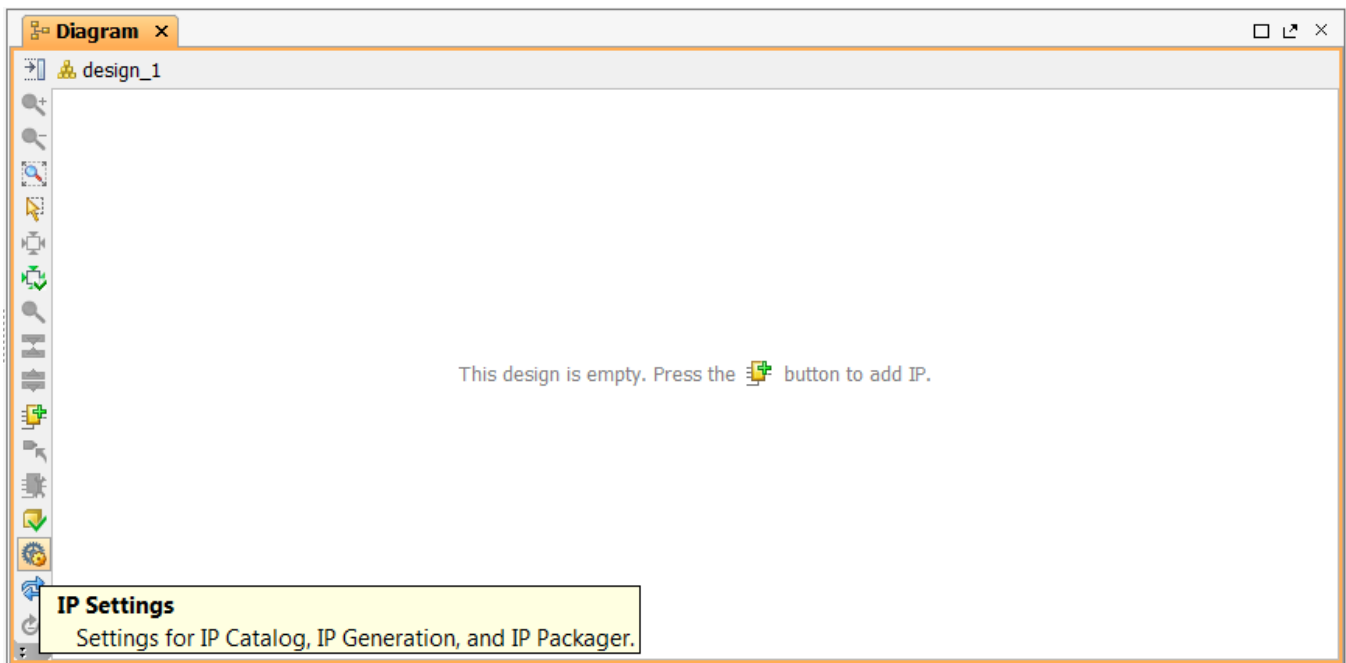

Figure 91: Open IP Settings

4. In the Repository Manager tab, click the Add Repository button (+) to add a repository.
5. Navigate to C:\SysGen_Tutorial\Lab8\sys_gen_ip\ip.
6. With folder ip selected, click **Select** to create the new repository as shown below.

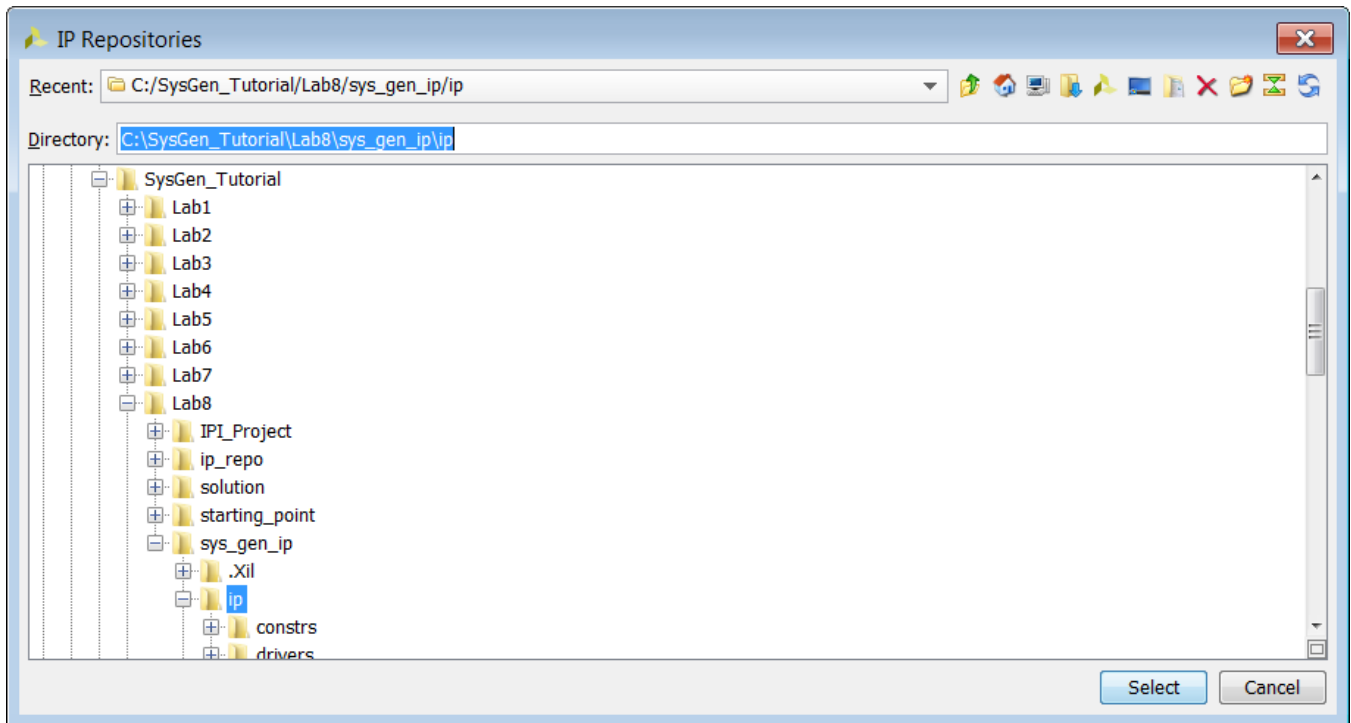

Figure 92: IP Repository ip

7. Click **OK** to exit the Add Repository dialog box.
8. Click **OK** to exit the Repository Manager.
9. Press the Add IP button in the center of the canvas.
10. Type `zynq` in the Search dialog box.
11. Double-click **ZYNQ7 Processing System** to add the CPU.

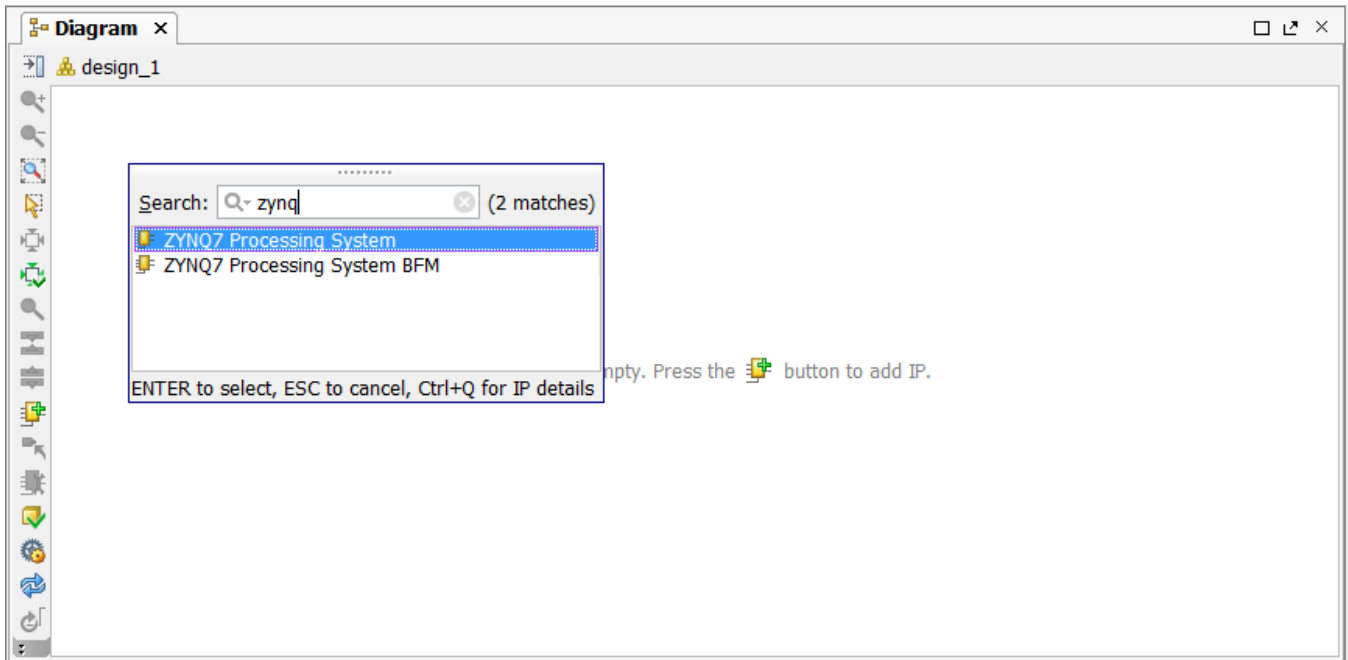

Figure 93: Adding the Zynq Processor

12. Click **Run Block Automation** as shown in the following figure.

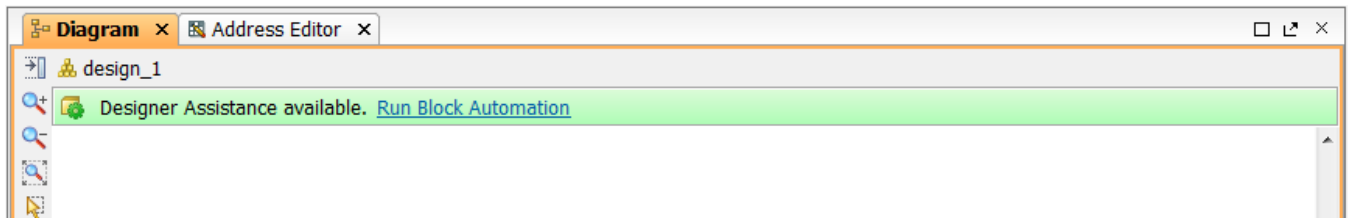

Figure 94: Block Automation

13. Leave **Apply Board Preset** selected and click **OK**. This will ensure the design is automatically configured to operate on the ZC702 evaluation board.

14. Right-click anywhere in the block diagram and select **Add IP**.

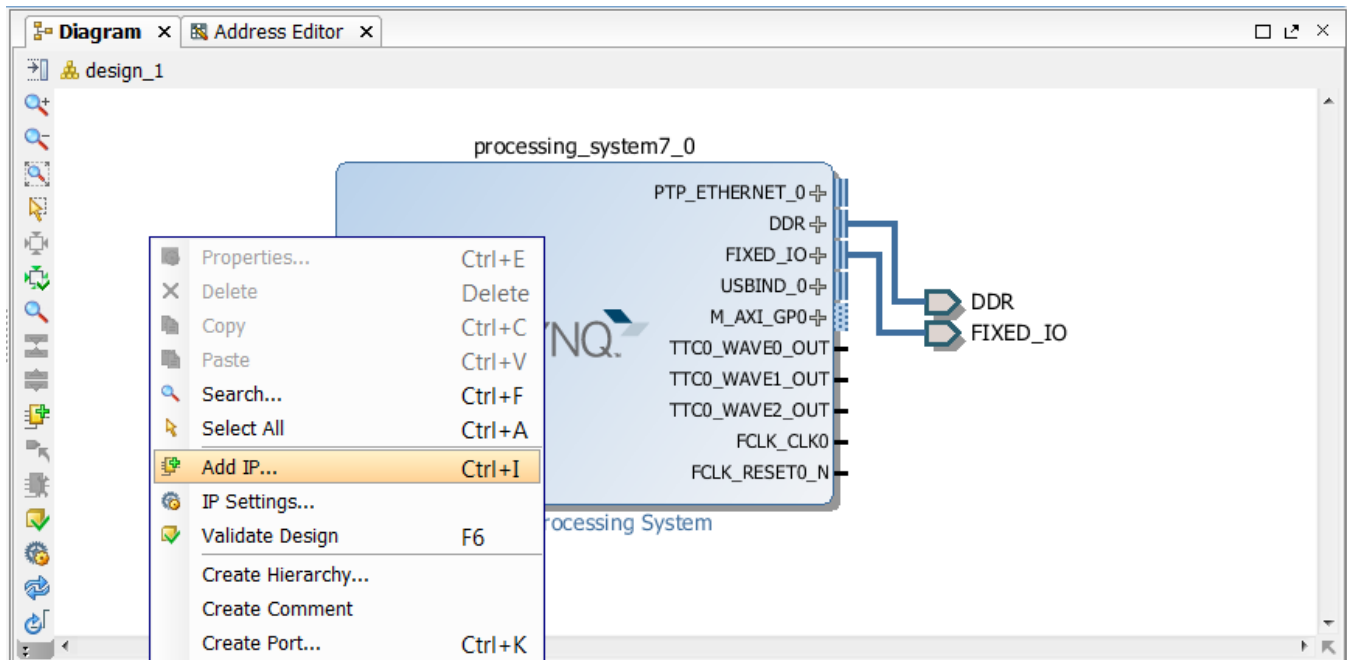

Figure 95: Add IP to the IP Integrator Diagram

15. Type lab8 in the Search dialog box.

16. Double-click lab8_1 to add the IP to the design.

You will now connect the IP to the rest of the design. Vivado IP Integrator provides automated assistance when the design uses AXI interfaces.

17. Click **Run Connection Automation** (at the top of the design canvas).

18. Click **OK** to accept the default options (lab8_1_0/lab8_1_s_axi to processing_system7_0/M_AXI_GP0) and connect the AXI4-Lite interface to the Zynq 7000 IP SoC.

19. Double-click the **ZYNQ7 Processing System** to customize the IP.

20. Click the **PS-PL Configuration** as shown in the figure below.

21. Expand the **HP Slave AXI Interface** and Select the **S AXI HP0 interface**.

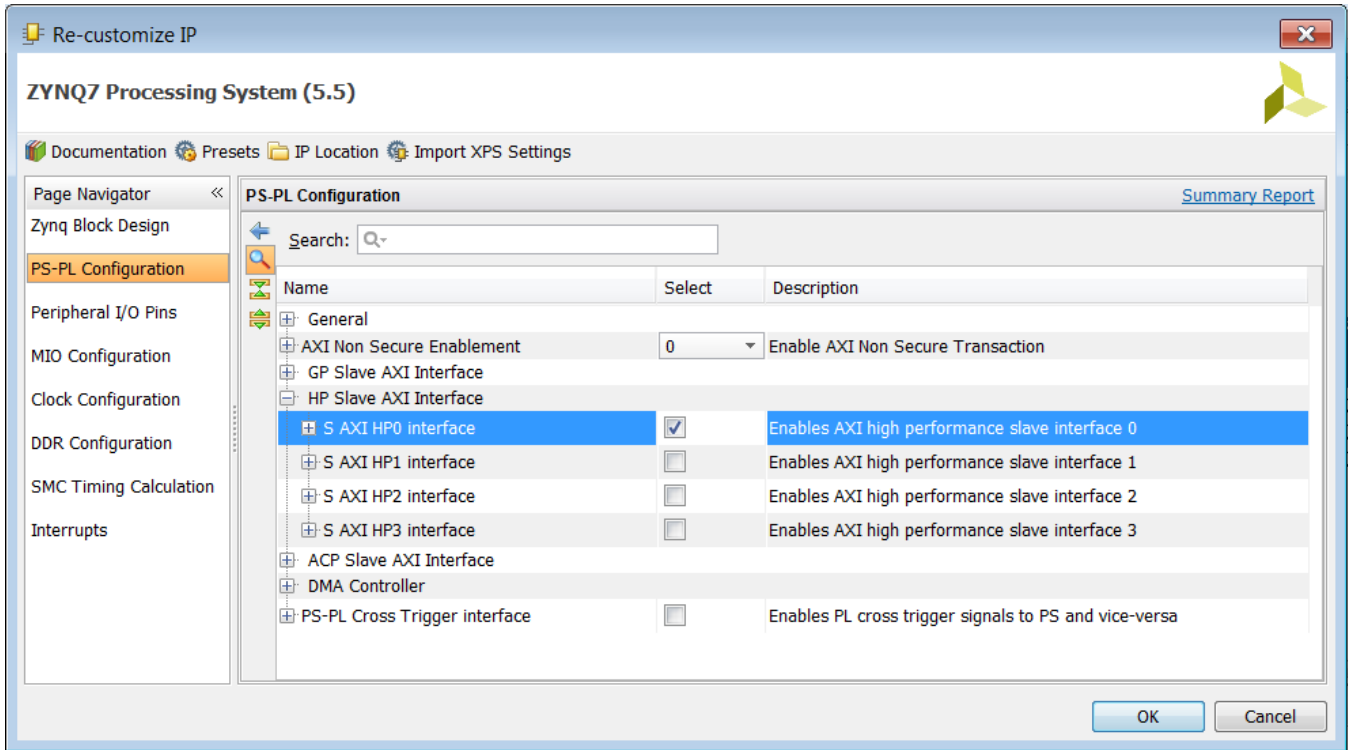

Figure 96: Customize the Zynq Processing System

22. Click **OK** to add this port to the Zynq Processing System.
23. On the System Generator IP **lab8_1** block, click the AXI4-Stream input interface port `s_axis_source` and drag the mouse. Possible valid connections are shown with green check marks as the pencil cursor approaches them. Drag the mouse to the `S_AXI_HP0` port on the `Zynq Processing System` to complete the connection.

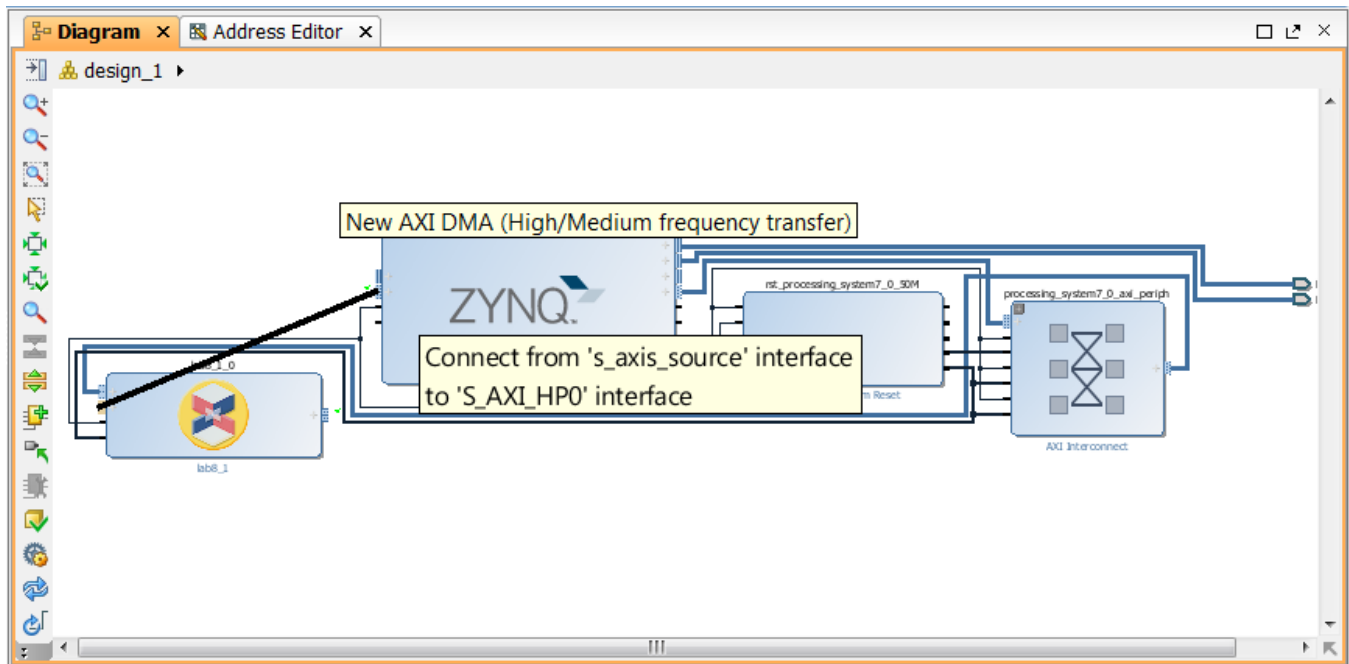

Figure 97: Connecting the AXI4-Stream Interface

24. Click **OK** in the Make Connection window.
25. Finally, click **Run Connection Automation** to connect the AXI4-Lite interface on the AXI DMA to the processor.
26. Click **OK** to accept the default.
27. Use the Validate Design toolbar button to confirm the design has no errors.

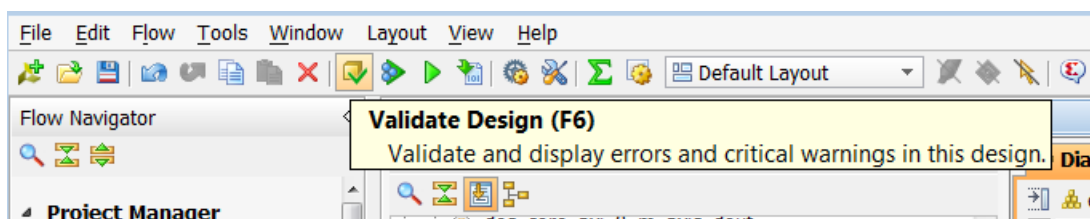

Figure 98: Validate the IPI Design

28. Click **OK** to close the Validate Design message.
- The design from System Generator has now been successfully incorporated into an IP Integrator design. The IP in the repository may be used within any Vivado project, by simply adding the repository to the project.
- You will now process the design through to bitstream.

Step 4: Implement the Design

In this step you will implement the IPI design and generate a bitstream.

1. Return to the Project Manager view by clicking **Project Manager** in the Flow Navigator.
2. In the Sources browser in the main workspace pane, a Block Diagram object called `design_1` is at the top of the Design Sources tree view.
3. Right-click this object and select **Generate Output Products**.

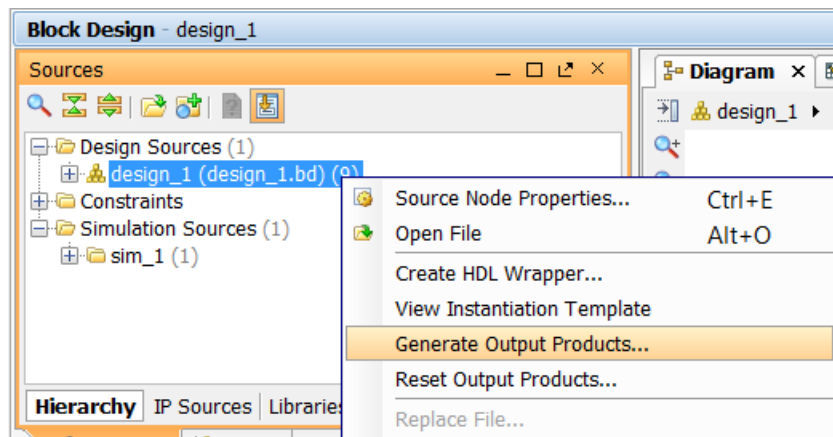

Figure 99: Generate Output Products

4. In the Generate Output Products dialog box, click **Generate** to start the process of generating the necessary source files.
5. When the generation completes, right-click the `design_1` object again, select **Create HDL Wrapper**, and click **OK** to exit the resulting dialog box.

The top level of the Design Sources tree becomes the `design_1_wrapper.v` file. The design is now ready to be synthesized, implemented, and to have an FPGA programming bitstream generated.

6. In the Flow Navigator, click **Generate Bitstream** to initiate the remainder of the flow.
7. Click **Yes** to generate the synthesis and implementation files.
8. In the dialog that appears after bitstream generation has completed, select **Open Implemented Design** and click **OK**.
9. Exit the Vivado IDE.

The next tutorial: [Lab 9: Using a System Generator Design with a Zynq-7000 AP SoC](#), shows how this design may be further processed using the Vivado IDE to implement this design with software on a Xilinx ZC702 evaluation board.

Summary

In this lab, you learned how AXI interfaces are added to a System Generator design and how a System Generator design is saved in IP Catalog format, incorporated into the Vivado IP Catalog, and used in a larger design. You also saw how IP Integrator can substantially increase productivity with connection automation and hints when AXI interfaces are used in your design.

The following solutions directory contains the final System Generator (*.slx) files for this lab. The solutions directory does not contain the IP output from System Generator or the files and directories generated when Vivado is executed.

```
C:/SysGen_Tutorial/Lab8/solution
```

Lab 9: Using a System Generator Design with a Zynq-7000 AP SoC

Introduction

In this lab, you will learn how to export your Vivado design with System Generator IP to a software environment and use driver files created by System Generator to quickly implement your project on a Xilinx evaluation board, running hardware with software in the same design.

Objectives

After completing this lab, you will be able to:

- Understand how to export your Vivado design with System Generator IP to a software environment (SDK).
- Understand how System Generator automatically creates software driver files for AXI4-Lite interfaces.
- Understand how to integrate the System Generator driver files into your software application.

Procedure

This exercise has two primary parts.

- In Step 1, you will review the AXI4-Lite interface and associated C drivers.
- In Step 2, you will export your Vivado design to a software environment and run it on a board.

Step 1: Review the AXI4-Lite Interface Drivers

In this step you review how AXI4-Lite interface drivers are provided when a design with an AXI4-Lite interface is saved.

This exercise uses the same design as [Lab 8: Using AXI Interfaces and IP Integrator](#).

1. Invoke System Generator and use the **Current Folder** browser to change the directory to:

C:\SysGen_Tutorial\Lab9.

2. At the command prompt, type `open Lab9_1.slx`.

This opens the design shown in the following figure.

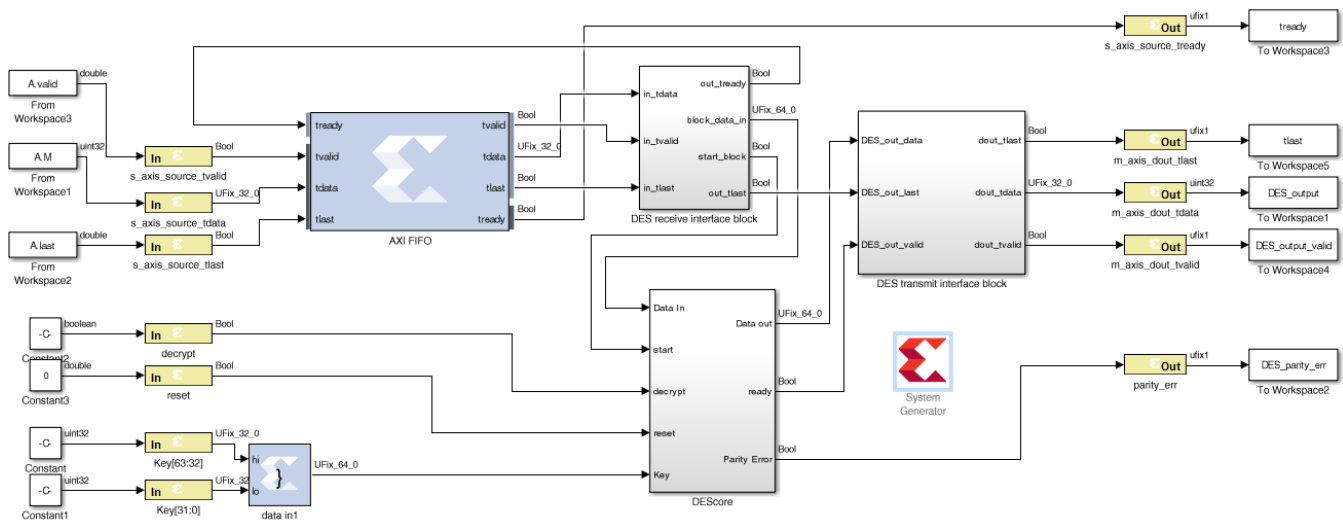

Figure 100: Lab9_1 Design

This design uses a number of AXI interfaces. These interfaces were reviewed in Lab 8 and the review is repeated here with additional details on the AXI4-Lite register addressing.

- Using AXI interfaces allows a design exported to the Vivado IP Catalog to be efficiently integrated into a greater system using IP integrator.
- It is *not* a requirement for designs exported to the IP Catalog to use AXI interfaces.

The design uses the following AXI interfaces:

- An AXI4-Stream interface is used for ports `s_axis_source_*`. All Gateway In and Out signals are prefixed with same name (`s_axis_source_*`) ensuring they are grouped into the same interface. The suffix for all ports are valid AXI4-Stream interface signal names (`tvalid`, `tlast` and `tdata`).
- An AXI4-Lite interface is used for the remaining ports. You can confirm this by performing the following steps:

3. Double-click Gateway In `decrypt` (or any of `reset`, `Keys [63:32]`, `Keys [31:0]`, `parity_err`).
4. In the Properties Editor select the **Implementation** tab.
5. Confirm the Interface is specified as AXI4-Lite in the Interface options.

Also note how the address of this port may be automatically assigned (as the current setting of **Auto assign address offset** indicates) or the address may be manually specified.

6. Click **OK** to exit the Properties Editor.

Details on simulating the design are provided in the canvas notes. For this exercise, you will concentrate on exporting the design to the Vivado IP catalog and use the IP in an existing design.

7. In the System Generator token, select **Generate** to generate a design in IP Catalog format.
8. Click **OK** to dismiss the Compilation status dialog box.
9. Click **OK** to dismiss the **System Generator** token.

10. In the file system, navigate to the directory

`C:\SysGen_Tutorial\Lab9\sys_gen_ip\ip\drivers\lab9_1_v1_2\src` and view the driver files.

The driver files for the AXI4-Lite interface are automatically created by System Generator when it saves a design in IP Catalog format.

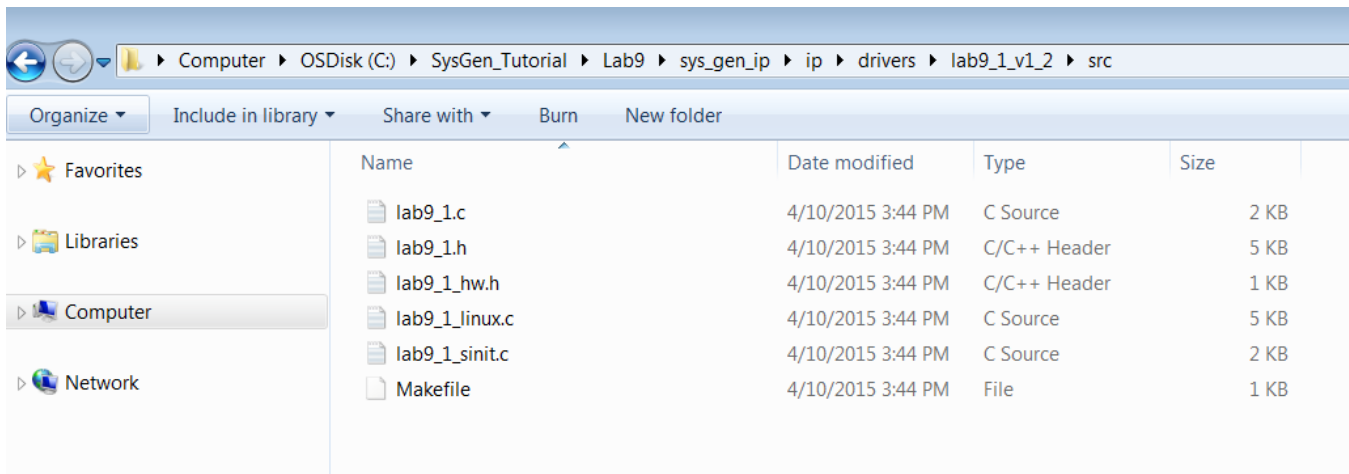

Figure 101: AXI4-Lite Driver Files

11. Open file `lab9_1_hw.h` to review which addresses the ports in the AXI4-Lite interface were automatically assigned.

```

/**
 *
 * @file lab9_1_hw.h
 *
 * This header file contains identifiers and driver functions (or
 * macros) that can be used to access the device. The user should refer to the
 * hardware device specification for more details of the device operation.
 */
#define LAB9_1_RESET 0x0/**< reset */
#define LAB9_1_DECRYPT 0x4/**< decrypt */
#define LAB9_1_KEY_63_32 0x8/**< key_63_32 */
#define LAB9_1_KEY_31_0 0xc/**< key_31_0 */
#define LAB9_1_PARITY_ERR 0x10/**< parity_err */
    
```

Figure 102: AXI4-Lite Address Assignment

12. Open file `lab9_1.c` to review the C code for the driver functions. These are used to read and write to the AXI4-Lite registers and can be incorporated into your C program running on the Zynq-7000 CPU. The function to write to the decrypt register is shown in the figure below.

```

#include "lab9_1.h"
#ifdef __linux__
int lab9_1_CfgInitialize(lab9_1 *InstancePtr, lab9_1_Config *ConfigPtr) {
    Xil_AssertNonvoid(InstancePtr != NULL);
    Xil_AssertNonvoid(ConfigPtr != NULL);

    InstancePtr->lab9_1_BaseAddress = ConfigPtr->lab9_1_BaseAddress;

    InstancePtr->IsReady = 1;
    return XST_SUCCESS;
}
#endif
void lab9_1_reset_write(lab9_1 *InstancePtr, u32 Data) {

    Xil_AssertVoid(InstancePtr != NULL);

    lab9_1_WriteReg(InstancePtr->lab9_1_BaseAddress, 0, Data);
}
u32 lab9_1_reset_read(lab9_1 *InstancePtr) {

    u32 Data;
    Xil_AssertVoid(InstancePtr != NULL);

    Data = lab9_1_ReadReg(InstancePtr->lab9_1_BaseAddress, 0);
    return Data;
}
void lab9_1_decrypt_write(lab9_1 *InstancePtr, u32 Data) {

    Xil_AssertVoid(InstancePtr != NULL);

    lab9_1_WriteReg(InstancePtr->lab9_1_BaseAddress, 4, Data);
}
    
```

Figure 103: AXI4-Lite Driver Code

The driver files are automatically included when the System Generator design is added to the IP Catalog. The procedure for adding a System Generator design to the IP Catalog is detailed in Lab 8. In the next step, you will implement the design

Step 2: Developing Software and Running it on the ZYNQ-7000 System

In this step you will use a copy of the design which was completed in Lab 8: Using AXI Interfaces and IP Integrator.

1. Open the Vivado IDE:
 - Use **Start > All Programs > Xilinx Design Tools > Vivado 2015.3 > Vivado 2015.3**

In this lab you will use the same design as Lab 8, but this time you will create the design using a Tcl file, rather than the interactive process used in Lab 8.

2. Using the Tcl console as shown in the following figure:
 - a. Type `cd C:/SysGen_Tutorial/Lab9/IPI_Project` to change to the project directory.
 - b. Type `source lab9_design.tcl` to create the RTL design.

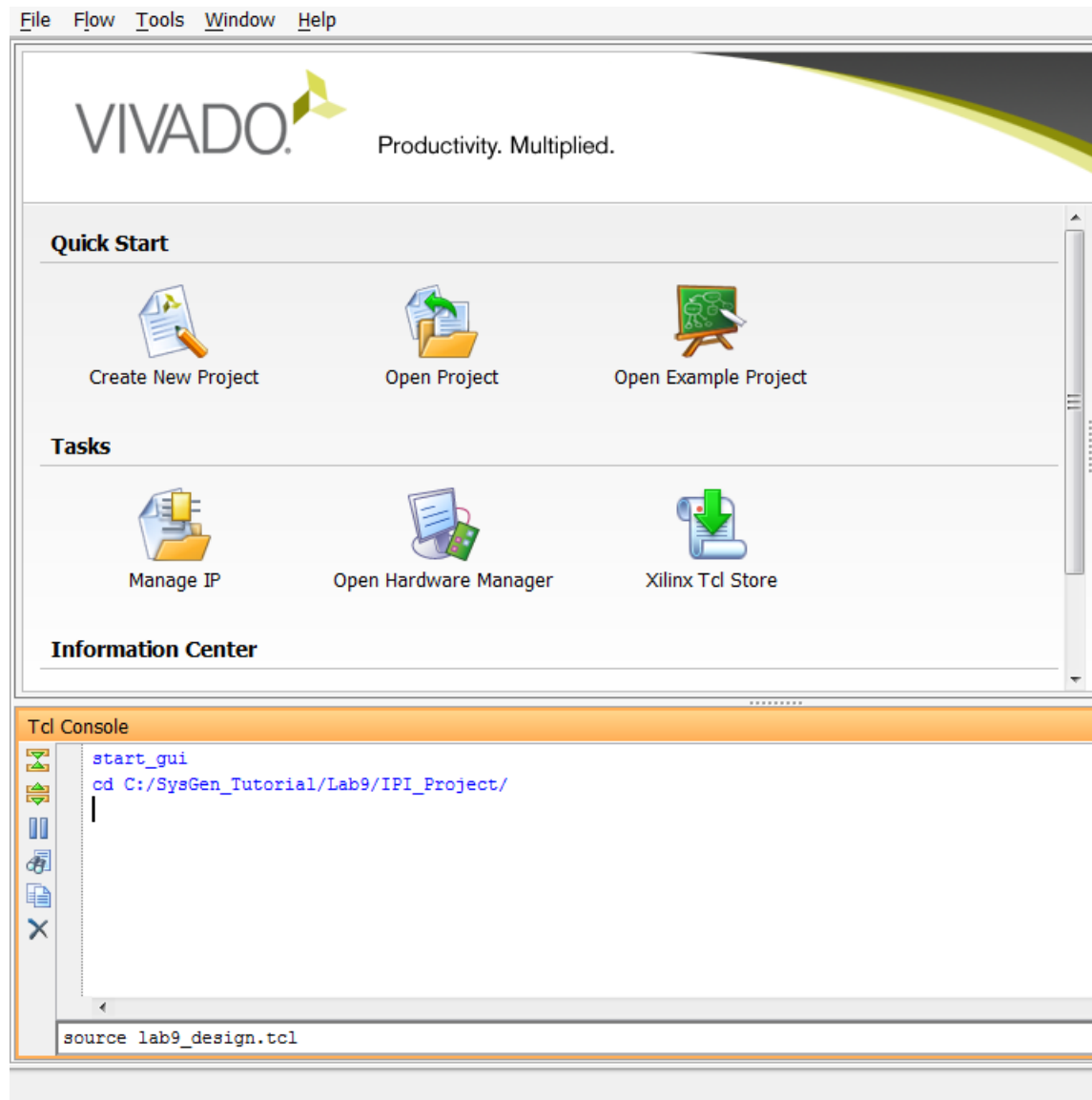

Figure 104: Lab9 IPI Design

This creates the project, creates the IPI design and builds the implementation (RTL synthesis, followed by place and route). *This may take some time to complete* (same as the final step of lab8).

When it completes:

3. Click **Open Implemented Design** in the Flow Navigator pane.
4. From the Vivado **File** menu select **Export > Export Hardware**.
5. In the Export Hardware dialog box make sure the **Include Bitstream** option is enabled.
Leave everything as local to the project.
6. Click **OK** to export the hardware.

7. From the Vivado **File** menu select **Launch SDK**.

In the Launch SDK dialog box, leave everything as local to the project.

8. Click **OK** to open SDK.

SDK opens. Observe that Sysgen IP `lab9_1` is listed in the IP blocks present in the design section of the `system.hdf` file.

***Note:** If the Welcome page is open, close it.*

9. From the SDK File menu, select **New > Application Project**.
10. Enter the project name `Des_Test` in the New Project dialog box.
A board support package will also be created as part of this step.
11. Click **Next**.
12. Select the **Hello World** template.
13. Click **Finish**.

You may expand the `Des_Test_bsp` container, as shown below, to confirm the AXI4-Lite driver code is included in the project.

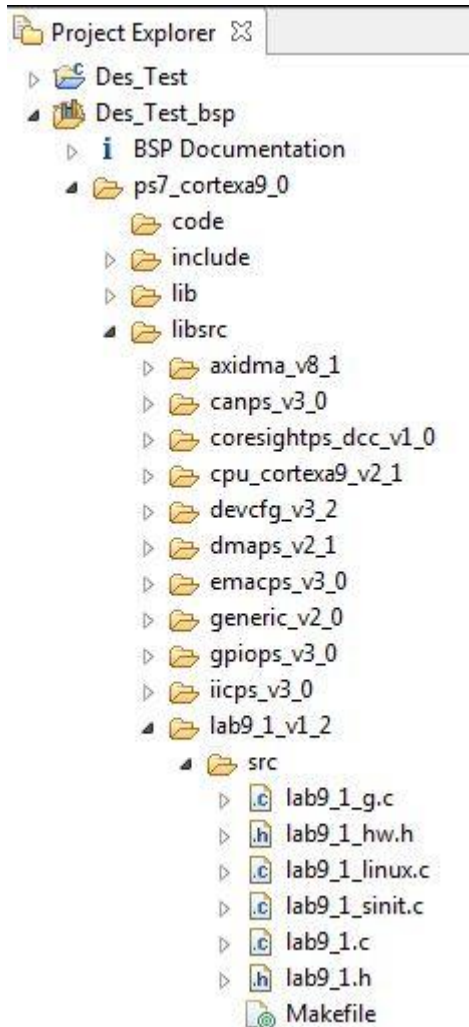

Figure 105: SDK Project

14. Power up the ZC702 board and program the FPGA.

Make sure the board has all the connections to allow you to download the bitstream on the FPGA device, and make sure switches SW10 and SW16 are set correctly. Refer to the documentation that accompanies the ZC702 development board.

15. Click **XilinxTools > Program FPGA**.

The Done LED (DS3) goes on.

16. Select the **SDK Terminal** tab at the bottom of the workspace.

17. To set up the terminal in the **SDK Terminal** tab, click the Connect icon and perform the following:
 - a. Select **Connection Type > Serial**.
 - b. Select the COM port to which the USB UART cable is connected. On Windows, if you are not sure, open the Device Manager and identify the port with the Silicon Labs driver under Ports (COM & LPT).
 - c. Change the Baud Rate to 115200.
 - d. Click **OK** to exit the Terminal Settings dialog box.
 - e. Check that terminal is connected by message in tab title bar.
18. Right-click application project Des_Test in the Project Explorer pane.
 - a. Select **Run As > Launch on Hardware**.
19. Switch to the **SDK Terminal** tab and confirm that `Hello World` was received.
20. Expand the container Des_Test and then expand the container src.
21. Double-click the `helloworld.c` file.
22. Replace the contents of this file with the contents of the file `hello_world_final.c` from the lab9 directory.
23. Save the `helloworld.c` source code.
24. Right-click application project Des_Test in the Explorer pane, and select **Run As > Launch on Hardware**.

***Note:** If a window opens containing the text "debug session already exists", click **OK** in that window.*
25. Review the results in the **SDK Terminal** tab (shown below).

```

/* initialize DES core
*/
Status = lab9_1_Initialize(&DES_inst, XPAR_LAB9_1_0_DEVICE_ID);

if (Status == XST_FAILURE) {
    print("DES core initialization FAILED\r\n");
    return -1;
} else {
    print("DES core initialization PASSED\r\n");
}
}
/*
 * Initialize the DMA Driver
 */
AxiDmaCfgPtr = XAxiDma_LookupConfig(XPAR_AXI_DMA_DEVICE_ID);
Status = XAxiDma_CfgInitialize(&PL_AXI_DMA_Device, AxiDmaCfgPtr);
if (Status != XST_FAILURE) {
    XAxiDma_IntrDisable(&PL_AXI_DMA_Device, XAXIDMA_IRQ_ALL_MASK, XAXIDMA_DEVICE_TO_DMA);
    XAxiDma_IntrDisable(&PL_AXI_DMA_Device, XAXIDMA_IRQ_ALL_MASK, XAXIDMA_DMA_TO_DEVICE);

    // execute test(s)
    for (i = 0; i < 100; i++) {
        run_DES_test(&DES_inst, &PL_AXI_DMA_Device);
    }
}

print("DES core - example all done\r\n");
return 0;
}

#endif

```

```

Serial: (COM4, 115200, 8, 1, None, None - CONNECTED) - Encoding: (ISO-8859-1)
This is a secret - 54 68 69 73 20 69 73 20 61 20 73 65 63 72 65 74
message that mu - 20 6d 65 73 73 61 67 65 20 74 68 61 74 20 6d 75
st be hidden, no - 73 74 20 62 65 20 68 69 64 64 65 6e 2c 20 6e 6f
matter what. Wa - 20 6d 61 74 74 65 72 20 77 68 61 74 2e 20 57 61
it - what?      - 69 74 20 2d 20 77 68 61 74 3f 20 20 20 20 20 20

Running DES accelerator tests...
DES key = 0x9867405801645880
DES plain text input:
This is a secret - 54 68 69 73 20 69 73 20 61 20 73 65 63 72 65 74
message that mu - 20 6d 65 73 73 61 67 65 20 74 68 61 74 20 6d 75
st be hidden, no - 73 74 20 62 65 20 68 69 64 64 65 6e 2c 20 6e 6f
matter what. Wa - 20 6d 61 74 74 65 72 20 77 68 61 74 2e 20 57 61
it - what?      - 69 74 20 2d 20 77 68 61 74 3f 20 20 20 20 20 20

AXI DMA Status = 10001000
AXI DMA Status = 10021002
DES cipher text output:
....YeF.\.g.O.. - 88 d7 b5 0e aa 59 65 46 ec 5c e1 67 91 4f a4 dd
b.M. |.v.zY....{ - 62 8a 4d f8 20 7c d1 76 2e 7a 59 da 93 d2 07 7b
.t..5.R.....$. - e3 74 15 1e 35 b5 52 9e 12 c6 11 db d8 0d 24 9c
...ZR.2a...^5." - 1e cd da 5a 52 d7 32 61 e0 0b da 5e 60 35 84 22
...b].V..._y..*. - d8 cf 89 62 5d c6 56 05 af 5f 02 79 b9 a2 2a 16

DES deciphered output:
This is a secret - 54 68 69 73 20 69 73 20 61 20 73 65 63 72 65 74
message that mu - 20 6d 65 73 73 61 67 65 20 74 68 61 74 20 6d 75
st be hidden, no - 73 74 20 62 65 20 68 69 64 64 65 6e 2c 20 6e 6f
matter what. Wa - 20 6d 61 74 74 65 72 20 77 68 61 74 2e 20 57 61
it - what?      - 69 74 20 2d 20 77 68 61 74 3f 20 20 20 20 20 20

DES core - example all done

```

Figure 106: Terminal Display

Summary

In this lab, you learned how to export your Vivado design containing System Generator IP to the SDK software environment and integrate the driver files automatically created by System Generator to run the application on the ZC702 board. You then viewed the result of the acceleration.

The following solutions directory contains the final System Generator (*.slx) files for this lab. The solutions directory does *not* contain the IP output from System Generator, the files and directories generated when Vivado is executed, or the SDK workspace.

```
C:/SysGen_Tutorial/Lab9/solution
```

Please Read: Important Legal Notices

The information disclosed to you hereunder (the "Materials") is provided solely for the selection and use of Xilinx products. To the maximum extent permitted by applicable law: (1) Materials are made available "AS IS" and with all faults, Xilinx hereby DISCLAIMS ALL WARRANTIES AND CONDITIONS, EXPRESS, IMPLIED, OR STATUTORY, INCLUDING BUT NOT LIMITED TO WARRANTIES OF MERCHANTABILITY, NON-INFRINGEMENT, OR FITNESS FOR ANY PARTICULAR PURPOSE; and (2) Xilinx shall not be liable (whether in contract or tort, including negligence, or under any other theory of liability) for any loss or damage of any kind or nature related to, arising under, or in connection with, the Materials (including your use of the Materials), including for any direct, indirect, special, incidental, or consequential loss or damage (including loss of data, profits, goodwill, or any type of loss or damage suffered as a result of any action brought by a third party) even if such damage or loss was reasonably foreseeable or Xilinx had been advised of the possibility of the same. Xilinx assumes no obligation to correct any errors contained in the Materials or to notify you of updates to the Materials or to product specifications. You may not reproduce, modify, distribute, or publicly display the Materials without prior written consent. Certain products are subject to the terms and conditions of the Limited Warranties which can be viewed at <http://www.xilinx.com/warranty.htm>; IP cores may be subject to warranty and support terms contained in a license issued to you by Xilinx. Xilinx products are not designed or intended to be fail-safe or for use in any application requiring fail-safe performance; you assume sole risk and liability for use of Xilinx products in Critical Applications: <http://www.xilinx.com/warranty.htm#critapps>.

©Copyright 2013-2015 Xilinx, Inc. Xilinx, the Xilinx logo, Artix, ISE, Kintex, Spartan, Virtex, Zynq, UltraScale and other designated brands included herein are trademarks of Xilinx in the United States and other countries. All other trademarks are the property of their respective owners.