

Kintex UltraScale FPGA KCU1250 Characterization Kit IBERT

Getting Started Guide

Vivado Design Suite

UG1061 (v2016.4) December 15, 2016

Revision History

The following table shows the revision history for this document.

| Date | Version | Revision |
|------------|---------|---|
| 12/15/2016 | 2016.4 | Updated for Vivado Design Suite 2016.4. Design file changed to rdf0352-kcu1250-ibert-2016-4.zip. |
| 10/12/2016 | 2016.3 | Updated for Vivado Design Suite 2016.3. Design file changed to rdf0352-kcu1250-ibert-2016-3.zip. Updated Figure 1-14 , Figure 2-1 , Figure 2-2 , and Figure 2-4 . |
| 06/08/2016 | 2016.2 | Updated for Vivado Design Suite 2016.2. Design file changed to rdf0352-kcu1250-ibert-2016-2.zip. Updated Figure 2-11 , Figure 2-12 , and Figure 2-13 . |
| 04/13/2016 | 2016.1 | Updated for Vivado Design Suite 2016.1. Design file rdf0352-kcu1250-ibert-2015-4.zip changed to rdf0352-kcu1250-ibert-2016-1.zip. Updated Figure 1-2 and Figure 1-20 . |
| 11/24/2015 | 2015.4 | Updated for Vivado Design Suite 2015.4. Design file rdf0352-kcu1250-ibert-2015-3.zip changed to rdf0352-kcu1250-ibert-2015-4.zip. |
| 10/07/2015 | 2015.3 | Updated for Vivado Design Suite 2015.3. Design file rdf0352-kcu1250-ibert-2015-2.zip changed to rdf0352-kcu1250-ibert-2015-3.zip. A step 7 was added to Starting the SuperClock-2 Module . Updated Figure 1-12 , Figure 2-2 , and Figure 2-5 through Figure 2-8 . |
| 06/30/2015 | 2015.2 | Updated for Vivado Design Suite 2015.2. Design file rdf0352-kcu1250-ibert-2015-1.zip changed to rdf0352-kcu1250-ibert-2015-2.zip. Board power on was added to step 3 , page 13 . Updated Figure 2-2 , Figure 2-4 , and Figure 2-8 . |
| 04/27/2015 | 2015.1 | Initial Xilinx release. |

Table of Contents

| | |
|---|----|
| Revision History | 2 |
| Chapter 1: KCU1250 IBERT Getting Started Guide | |
| Overview | 4 |
| Requirements..... | 5 |
| Setting Up the KCU1250 Board | 5 |
| Extracting the Project Files | 6 |
| Running the GTH IBERT Demonstration | 7 |
| Chapter 2: Creating the GTH IBERT Core | |
| Appendix A: Warranty | |
| Appendix B: Additional Resources and Legal Notices | |
| Xilinx Resources | 38 |
| Solution Centers..... | 38 |
| References | 38 |
| Please Read: Important Legal Notices | 39 |

KCU1250 IBERT Getting Started Guide

Overview

This document describes setting up the Kintex® UltraScale™ FPGA KCU1250 GTH Transceiver Characterization Board to run the Integrated Bit Error Ratio Test (IBERT) demonstration using the Vivado® Design Suite. The designs required to run the IBERT demonstration are stored in a Secure Digital (SD) memory card provided with the KCU1250 board. The demonstration shows the capabilities of the Kintex UltraScale XCKU040-FFVA1156 FPGA GTH transceiver.

The KCU1250 board is described in detail in the *KCU1250 Board User Guide* (UG1057) [Ref 1].

The IBERT demonstration operates one GTH Quad. The procedure consists of:

1. [Setting Up the KCU1250 Board, page 5](#)
2. [Extracting the Project Files, page 6](#)
3. [Connecting the GTH Transceivers and Reference Clocks, page 7](#)
4. [Starting the SuperClock-2 Module, page 12](#)
5. [Configuring the FPGA, page 15](#)
6. [Setting Up the Vivado Design Suite, page 17](#)
7. [Viewing GTH Transceiver Operation, page 23](#)
8. [Closing the IBERT Demonstration, page 24](#)

Requirements

The hardware and software required to run the GTH IBERT demonstrations are:

- Kintex UltraScale FPGA KCU1250 GTH Transceiver Characterization Board, including:
 - One SD card containing the IBERT demonstration designs
 - One Samtec Bulls Eye cable
 - Eight SMA female-to-female (F-F) adapters
 - Six 50-Ω SMA terminators
 - UltraScale transceiver power supply module (installed)
 - SuperClock-2 module, Rev 1.0 (installed)
 - Active BGA heat sink (installed)
 - 12V DC power adapter
 - Two USB cables, standard-A plug to micro-B plug
- Host PC with:
 - SD card reader
 - USB ports
- Xilinx® Vivado Design Suite 2016.4

The hardware and software required to rebuild the IBERT demonstration designs are:

- Xilinx Vivado Design Suite 2016.4
- PC with a version of the Windows operating system supported by Xilinx Vivado Design Suite

Setting Up the KCU1250 Board

This section describes how to set up the KCU1250 board.



CAUTION! The KCU1250 board can be damaged by electrostatic discharge (ESD). Follow standard ESD prevention measures when handling the board, such as using a grounding strap and static dissipative mat.

When the KCU1250 board ships from the factory, it is configured for the GTH IBERT demonstrations described in this document. If the board has been re-configured, it must be returned to the default setup before running the IBERT demonstrations.

1. Move all jumpers and switches to their default positions. The default jumper and switch positions are listed in the *KCU1250 Board User Guide* (UG1057) [Ref 1].
2. Install the UltraScale transceiver power module by plugging it into connectors J124 and J46.
3. Install the SuperClock-2 module:
 - a. Align the three metal standoffs on the bottom side of the module with the three mounting holes in the SUPERCLOCK-2 MODULE interface of the KCU1250 board.
 - b. Using three 4-40 x 0.25 inch screws, firmly screw down the module from the bottom of the KCU1250 board.
 - c. On the SuperClock-2 module, place a jumper across pins 2–3 (2V5) of the CONTROL VOLTAGE header, J18, and place another jumper across Si570 INH header J11.
 - d. Screw down a 50Ω SMA terminator onto each of the six unused Si5368 clock output SMA connectors: J7, J8, J12, J15, J16 and J17.

Extracting the Project Files

The Vivado Design Suite BIT files required to run the IBERT demonstrations are located in `rdf0352-kcu1250-ibert-2016-4.zip` on the SD card provided with the KCU1250 board. The BIT files are also available online at the [Kintex UltraScale FPGA KCU1250 Characterization Kit documentation](#) website.

The ZIP file contains these BIT files:

- `kcu1250_ibert_q224_125.bit`
- `kcu1250_ibert_q225_125.bit`
- `kcu1250_ibert_q226_125.bit`
- `kcu1250_ibert_q227_125.bit`
- `kcu1250_ibert_q228_125.bit`

To copy the files from the SD card:

1. Connect the SD card to the host computer.
2. Locate the file `rdf0352-kcu1250-ibert-2016-4.zip` on the SD card.
3. Unzip the files to a working directory on the host computer.

Running the GTH IBERT Demonstration

The GTH IBERT demonstration operates one GTH Quad at a time. This section describes how to test GTH Quad 224. The remaining GTH Quads can be tested following a similar series of steps.

Connecting the GTH Transceivers and Reference Clocks

Figure 1-1 shows the locations for GTH transceiver Quads 224, 225, 226, 227, and 228 on the KCU1250 board.

Figure 1-1 is for reference only and might not reflect the current revision of the board.

Note: QUAD 131 and QUAD 132 are not available on the XCKU040 device.

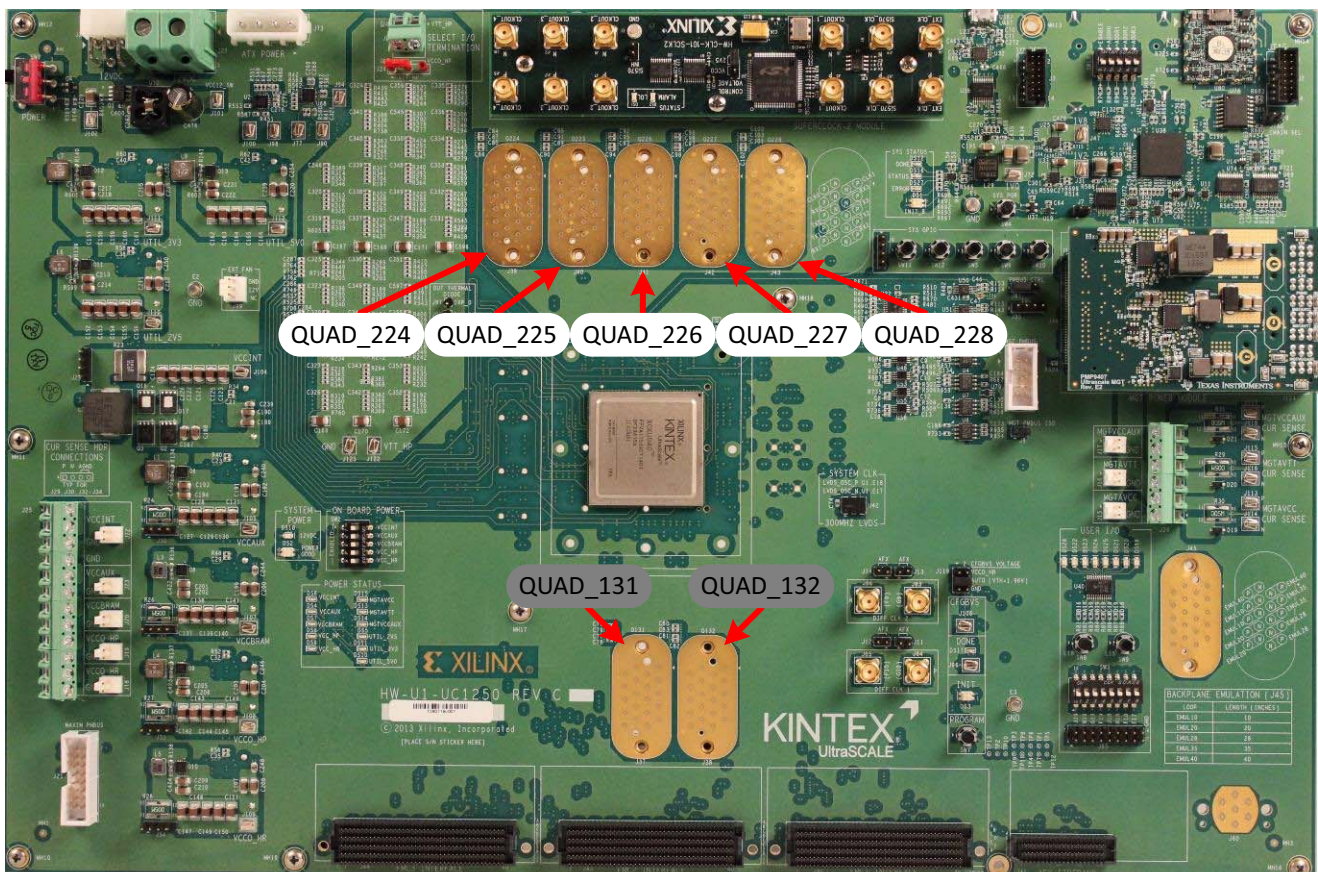

X16282-030416

Figure 1-1: GTH Quad Locations

All GTH transceiver pins and reference clock pins are routed from the FPGA to a connector pad that interfaces with Samtec Bulls Eye connectors. **Figure 1-2 A** shows the connector pad. **Figure 1-2 B** shows the connector pinout.

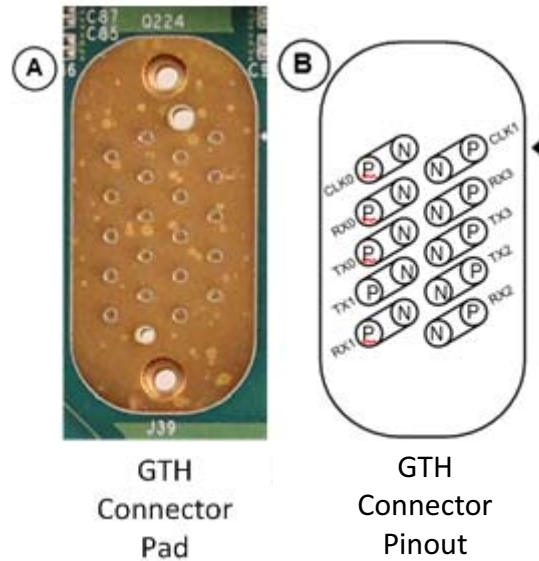

X16283-030416

Figure 1-2: A – GTH Connector Pad. B – GTH Connector Pinout

The SuperClock-2 module provides LVDS clock outputs for the GTH transceiver reference clocks in the IBERT demonstrations. **Figure 1-3** shows the locations of the differential clock SMA connectors on the clock module which can be connected to the reference clock cables.

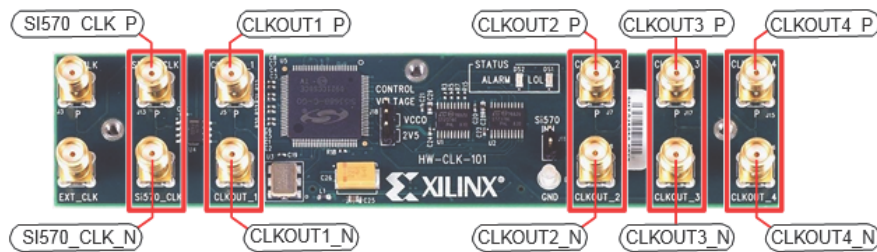

X16284-030416

Figure 1-3: SuperClock-2 Module Output Clock SMA Locations

The four SMA pairs labeled CLKOUT provide LVDS clock outputs from the Si5368 clock multiplier/jitter attenuator device on the clock module. The SMA pair labeled Si570_CLK provides LVDS clock output from the Si570 programmable oscillator on the clock module.

Note: The Si570 oscillator does not support LVDS output on the Rev B and earlier revisions of the SuperClock-2 module.

For more information on the SuperClock-2 module, see the *HW-CLK-101-SCLK2 SuperClock-2 Module User Guide (UG770)* [Ref 2].

Attach the GTH Quad Connector

Before connecting the Bulls Eye cable assembly to the board, firmly secure the blue elastomer seal provided with the cable assembly to the bottom of the connector housing if it is not already inserted (see [Figure 1-4](#)).

Note: [Figure 1-4](#) is for reference only and might not reflect the current version of the connector.



X16285-030416

Figure 1-4: Bulls Eye Connector with Elastomer Seal

Attach the Samtec Bulls Eye connector to GTH Quad 224 ([Figure 1-5](#)), aligning the two indexing pins on the bottom of the connector with the guide holes on the board. Hold the connector flush with the board and fasten it by tightening the two captive screws.

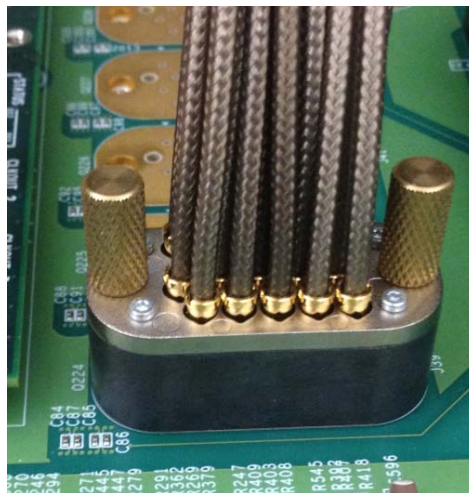

GTH Transceiver Clock Connections

See [Figure 1-2](#) to identify the P and N coax cables that are connected to the CLK0 reference clock inputs. Connect these cables to the SuperClock-2 module as follows:

- CLK0_P coax cable → SMA connector J7 (CLKOUT1_P) on the SuperClock-2 module
- CLK0_N coax cable → SMA connector J8 (CLKOUT1_N) on the SuperClock-2 module

Note: Any one of the five differential outputs from the SuperClock-2 module can be used to source the GTH reference clock. CLKOUT1_P and CLKOUT1_N are used here as an example.

GTH TX/RX Loopback Connections

See [Figure 1-2](#) to identify the P and N coax cables that are connected to the four receivers (RX0, RX1, RX2, and RX3) and the four transmitters (TX0, TX1, TX2, and TX3). Use eight SMA female-to-female (F-F) adapters ([Figure 1-6](#)) to connect the transmit and receive cables as shown in [Figure 1-7](#):

- TX0_P → SMA F-F Adapter → RX0_P
- TX0_N → SMA F-F Adapter → RX0_N
- TX1_P → SMA F-F Adapter → RX1_P
- TX1_N → SMA F-F Adapter → RX1_N
- TX2_P → SMA F-F Adapter → RX2_P
- TX2_N → SMA F-F Adapter → RX2_N
- TX3_P → SMA F-F Adapter → RX3_P
- TX3_N → SMA F-F Adapter → RX3_N

Note: To ensure good connectivity, it is recommended that the adapters be secured with a wrench; however, do not over-tighten the SMAs.



Figure 1-6: SMA F-F Adapter

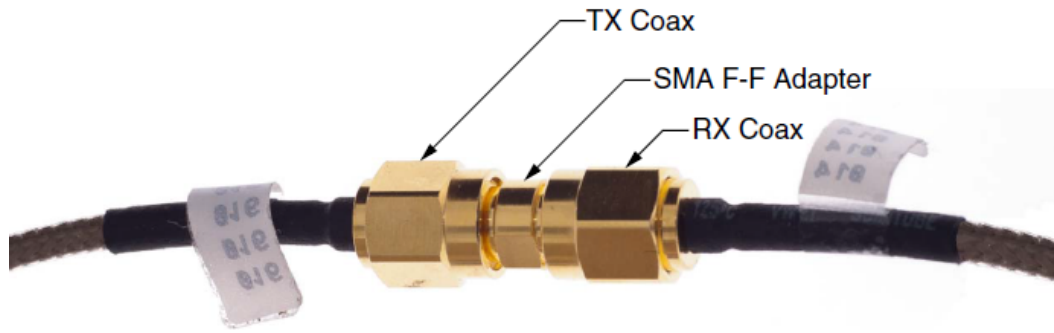

X16288-030416

Figure 1-7: TX-to-RX Loopback Connection Example

Figure 1-8 shows the KCU1250 board with the cable connections required for the Quad 224 GTH IBERT demonstration.

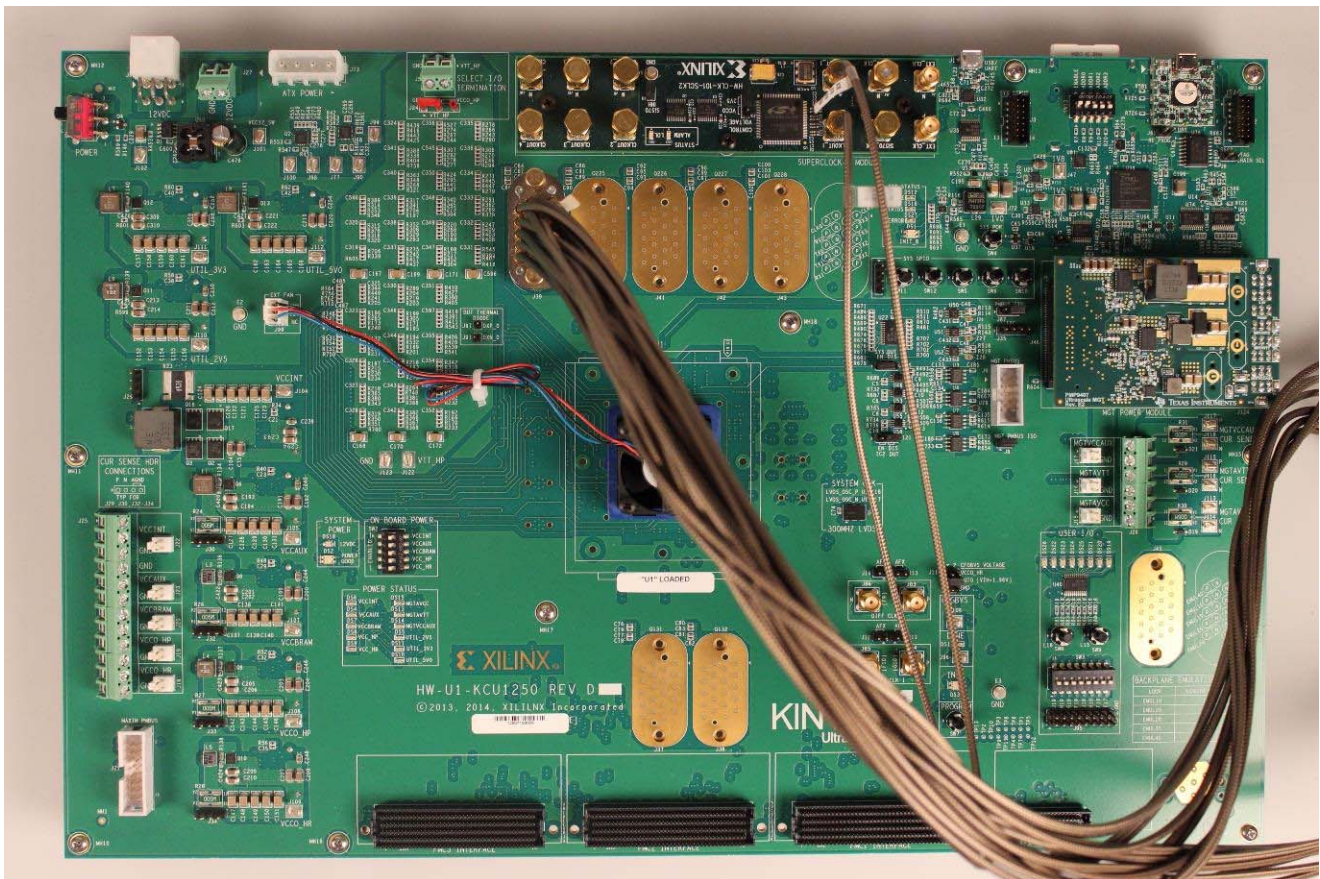

X16289-030416

Figure 1-8: Cable Connections for Quad 224 GTH IBERT Demonstration

Starting the SuperClock-2 Module

The SuperClock-2 module features two clock-source components:

- Always-on Si570 crystal oscillator
- Si5368 jitter-attenuating clock multiplier

Outputs from either source can be used to drive the transceiver reference clocks.

To start the SuperClock-2 module:

1. The SuperClock-2 module is configured using the Xilinx XC7Z010CLG225 Zynq-7000APSoC System Controller command line which can be accessed through a serial communication terminal connection using the enhanced communication port of the Silicon Labs USB to Dual UART Bridge (Figure 1-9). Additional information about the Silicon Labs USB-to-UART is available in *Silicon Labs CP210x USB-to-UART Installation Guide* (UG1033) [Ref 3].

Review the *KCU1250 Board User Guide* (UG1057) [Ref 1] for additional information about the System Controller.

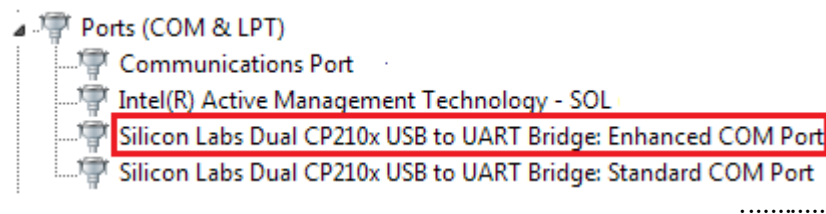
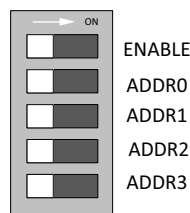

Figure 1-9: Silicon Labs Enhanced COM PORT

2. Set the System Controller configuration DIP switches (SW13) to the OFF position (Figure 1-10). This disables configuration of the FPGA at power reset.



X16291-030416

Figure 1-10: Configuration DIP Switch (SW13)

3. Connect J1 connector (USB/UART) on the KCU1250 board to the host computer using one of the standard-A plug to micro-B plug USB cables provided (Figure 1-11) and power up the board by placing SW1 in the ON position.



X16292-030416

Figure 1-11: **USB-UART Connector**

4. Open a serial communication terminal application on the host computer, for example "HyperTerminal", and connect to the port number associated with the **enhanced COM port** of the Silicon Lab USB-UART Bridge. Set up a new connection as in Figure 1-12, and press the **Return** key to connect and view the **System Controller** options menu.

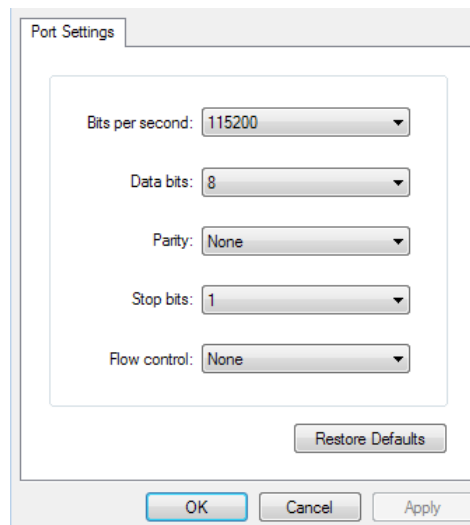

X16293-030416

Figure 1-12: **Terminal Setting**

- From the main **System Controller** menu, select option (1) to access the SuperClock-2 options:

```
KCU1250 System Controller
```

```
    - Main Menu -
```

```
-----
```

- 1. Set Programmable Clocks**
2. Get Power System (PMBUS) Voltages
3. Get Power Monitoring Data (INA226)
4. Adjust FPGA Mezzanine Card (FMC) Settings
5. Get GPIO Data
6. Get EEPROM Data
7. Configure UltraScale FPGA

```
Select an option
```

- Use the Programmable Clocks menu option (2) to set the output clock frequencies of the Si5368 clocks to 125 MHz.

```
KCU1250 System Controller
```

```
    - Clock Menu -
```

```
-----
```

1. Set KCU1250 Si570 Frequency
- 2. Set KCU1250 Si5368 Frequency**
3. Save KCU1250 Clock Frequency to EEPROM
4. Restore KCU1250 Clock Frequency from EEPROM
5. View KCU1250 Saved Clocks in EEPROM
6. Set KCU1250 Clock Restore Options
7. Read KCU1250 Si570 Frequency
8. Read KCU1250 Si5368 Frequency
0. Return to Main Menu

```
Select an option
```

7. Select option 2 (Free-Run crystal) operating mode when prompted.

Choose si5368 operating mode:

1 - Auto-Select

2 - Free-Run using XA-XB crystal

Configuring the FPGA

The KCU1250 board additionally utilizes the Xilinx XC7Z010CLG225 Zynq-7000 AP SoC System Controller to implement a System Integrated Configuration Engine (System ICE) to configure the FPGA using one of the configuration *.bit files provided on the SD card in 8-bit SMAP configuration mode.

The FPGA can also be configured through the Vivado Design Suite using the *.bit files available on the SD card and online (as collection `rdf0352-kcu1250-ibert-2016-4.zip`) at the [Kintex UltraScale FPGA KCU1250 Characterization Kit documentation](#) website.

Review *UltraScale Architecture Configuration User Guide* (UG570) [Ref 4] for additional information about UltraScale device configuration.

1. Insert the SD card provided with the KCU1250 board into the SD card reader slot located on the bottom-side (upper-right corner) of the KCU1250 board.
2. From the main **System Controller** menu, select option (7) to access the SuperClock-2 options:

```
KCU1250 System Controller
```

```
- Main Menu -
```

```
-----
```

1. Set Programmable Clocks
2. Get Power System (PMBUS) Voltages
3. Get Power Monitoring Data (INA226)
4. Adjust FPGA Mezzanine Card (FMC) Settings
5. Get GPIO Data
6. Get EEPROM Data

7. Configure UltraScale FPGA

Select an option

3. Select option (1) to configure the FPGA from the SD card:

```
KCU1250 System Controller
```

```
- CONFIG Menu -
```

```
-----
```

1. Configure UltraScale FPGA from SD Card

```
0. Return to Main Menu
```

```
Select an option
```

The IBERT design demonstrations included with the SD cards can be selected using one of the set numbers listed in [Table 1-1](#).

Table 1-1: IBERT Examples Bitstream Number

| IBERT Demonstration Design | Bitstream Number |
|----------------------------|------------------|
| QUAD_224 | 0 |
| QUAD_225 | 1 |
| QUAD_226 | 2 |
| QUAD_227 | 3 |
| QUAD_228 | 4 |

4. Select option (0) to configure the FPGA with the Quad 224 IBERT example design. Press **Enter** and review the terminal for configuration progress:

```
Enter a Bitstream number (0-15):
```

```
0
```

```
Info: xilinx.sys opened
```

```
Info: Opening rev_1/set0/config.def
```

```
Info: Configuration definition file "rev_1/set0/config.def"
opened
```

```
Info: Clock divider is set to 2
```

```
Info: Configuration clock frequency is 25MHz
```

```
Info: Bitfile "rev_1/set0/ibert224.bit" opened
```

```
...10%...20%...30%...40%...50%...60%...70%...80%...90%...100%
```

```
Configuration completed successfully
```

Setting Up the Vivado Design Suite

1. Connect the host computer to the KCU1250 board using the second standard-A plug to micro-B plug USB cable. The standard-A plug connects to a USB port on the host computer and the micro-B plug connects to U80, the Digilent USB JTAG configuration port on the KCU1250 board (Figure 1-13).



X16294-030416

Figure 1-13: USB-UART Connector

2. Start the Vivado Design Suite on the host computer and click **Flow > Open Hardware Manager** (highlighted in [Figure 1-14](#)).

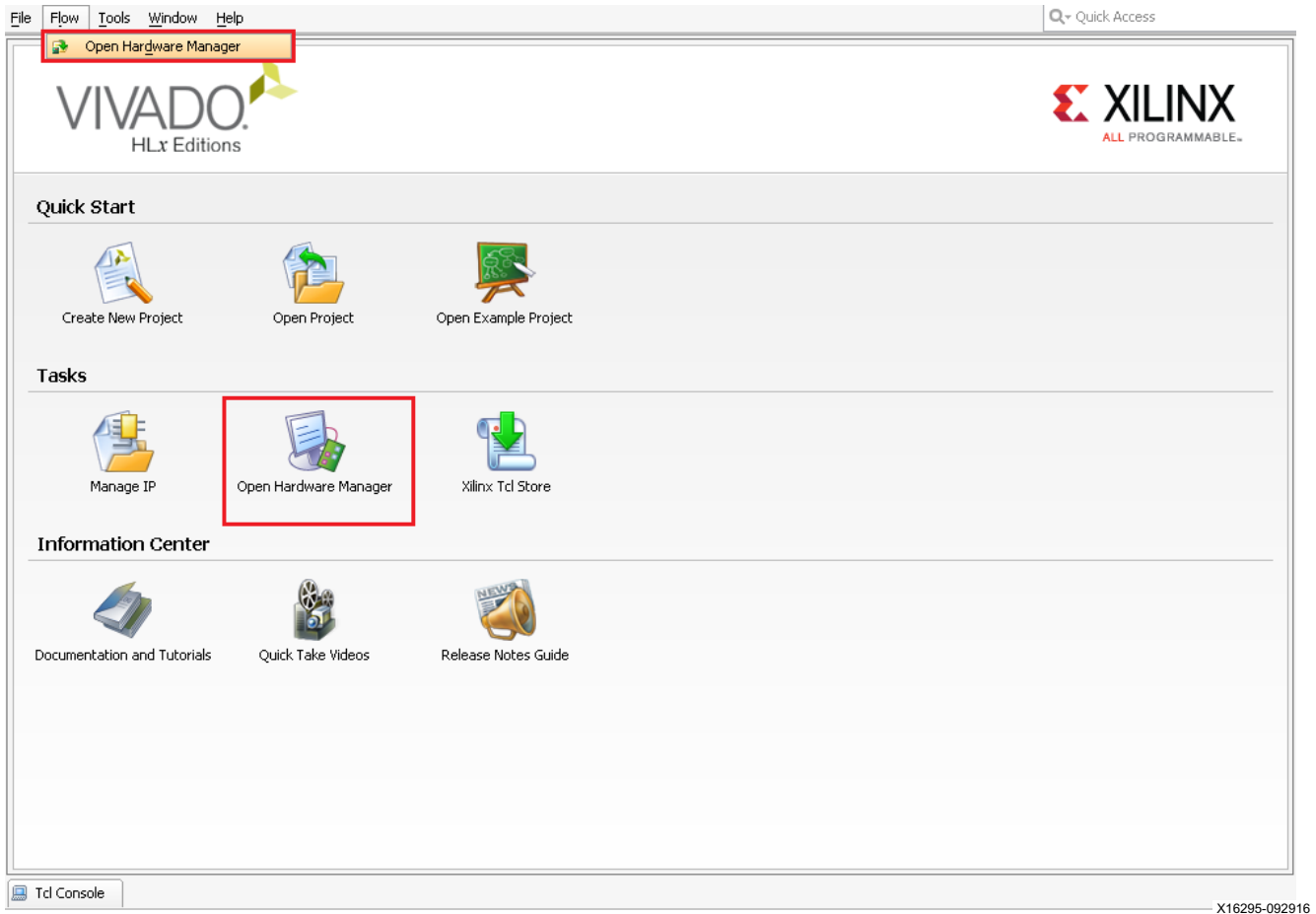

Figure 1-14: Vivado Design Suite, Open Hardware Manager

3. In the **Hardware Manager** window (Figure 1-15), click **Open New Target**.

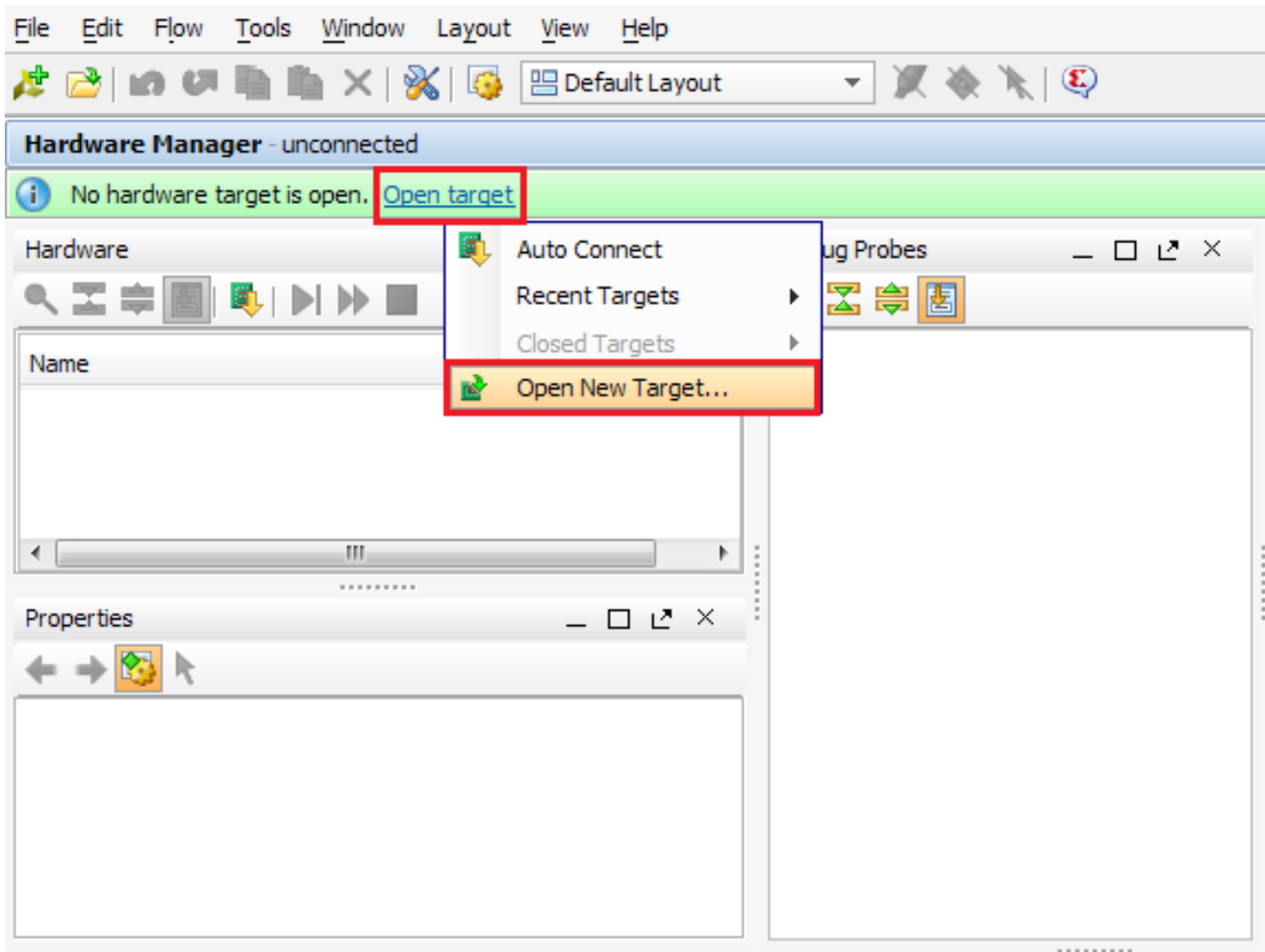
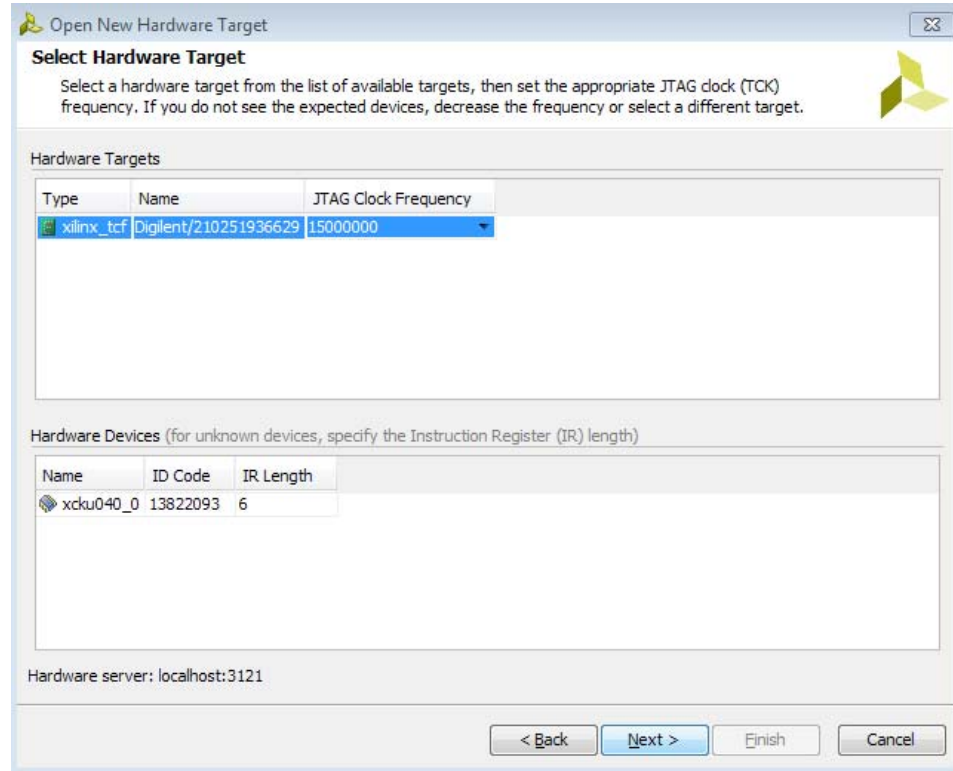

Figure 1-15: Open a New Hardware Manager

4. An **Open Hardware Target** wizard opens. Click **Next** in the first window.
5. In the **Hardware Server Settings** window, select **Local server (target is on local machine)**. Click **Next**.

- In the **Select Hardware Target** window, the **xilinx_tcf** cable appears under **Hardware Targets**, and the JTAG chain contents of the selected cable appear under **Hardware Devices** (Figure 1-16). Select the **xilinx_tcf_Digilent** target and keep the JTAG Clock Frequency at the default value (**15 MHz**). Click **Next**.



X16297-030416

Figure 1-16: Select Hardware Target

- In the **Open Hardware Target Summary** window, click **Finish**. The wizard closes and the Vivado Design Suite opens the hardware target.
- A dialog to auto-detect the I/O links for the IBERT cores is displayed if the Vivado Design Suite default warnings and notifications setting has not been changed. Press **Yes** to automatically detect the links (Figure 1-17).

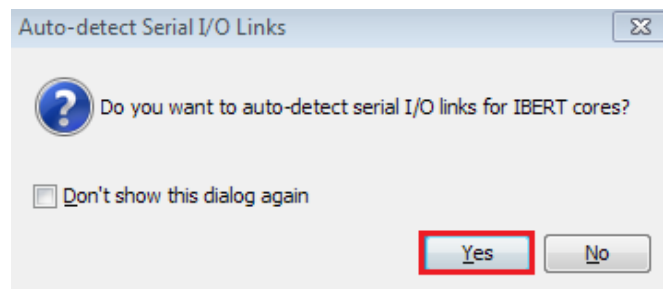

X16298-030416

Figure 1-17: Auto-Detect the Serial I/O Links

- Alternatively, to view the GTH transceiver operation, click **Layout > Serial I/O Analyzer**. From the top of the **Hardware Manager** window, select **Auto-Detect Links** to display all available links automatically. Links can also be created manually in the **Links** window by right-clicking and selecting **Create Links** or by clicking the **Create Links** button (Figure 1-18).

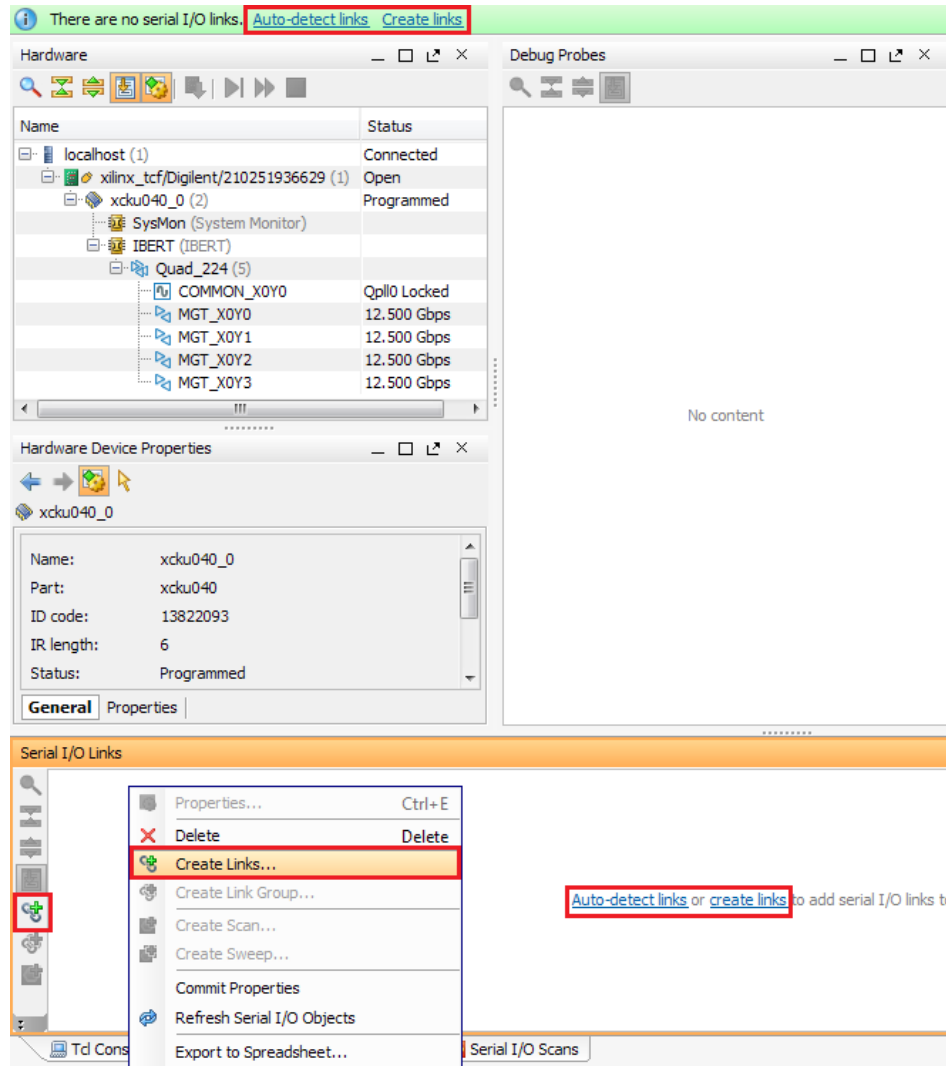

X16299-030416

Figure 1-18: Serial I/O Analyzer – Create Links

10. If links are created manually, the **Create Links** window is displayed. The options in this window are used to link any TX GT to any RX GT. To create links, select the TX GT and RX GT from the two lists, then click the **Add (+)** button. For this project, connect the following links (Figure 1-19):

- MGT_X0Y0/TX (xcku040_0/Quad_224) to MGT_X0Y0/RX (xcku040_0/Quad_224)
- MGT_X0Y1/TX (xcku040_0/Quad_224) to MGT_X0Y1/RX (xcku040_0/Quad_224)
- MGT_X0Y2 /TX (xcku040_0/Quad_224) to MGT_X0Y2/RX (xcku040_0/Quad_224)
- MGT_X0Y3/TX (xcku040_0/Quad_224) to MGT_X0Y3/RX (xcku040_0/Quad_224)

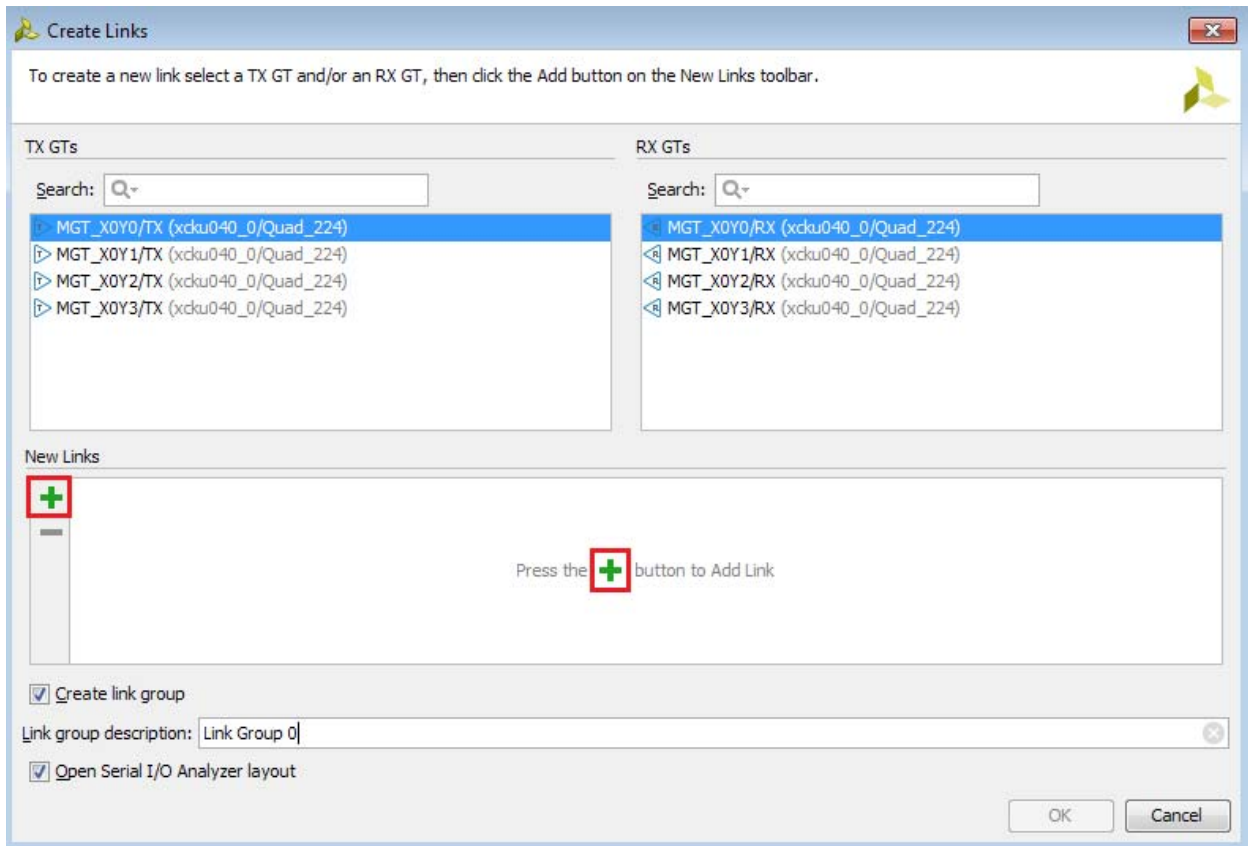

X16300-030416

Figure 1-19: **Create Links Window**

Viewing GTH Transceiver Operation

After completing [step 10, page 22](#) in [Setting Up the Vivado Design Suite](#), the IBERT demonstration is configured and running. The status and test settings are displayed on the **Links** tab in the **Links** window shown in [Figure 1-20](#).

Note the line rate and RX bit error count. The line rate for all four GTH transceivers is 12.5 Gb/s (see MGT Link Status in [Figure 1-20](#)). Verify that there are no bit errors.

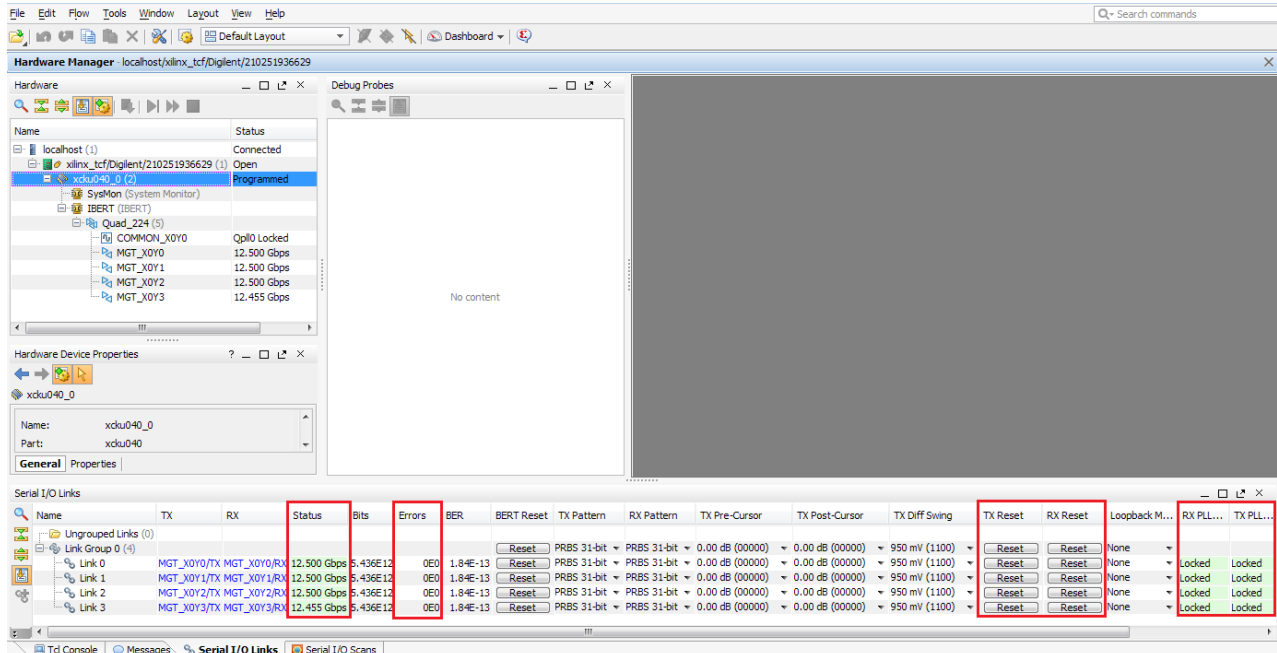

X16301-030416

Figure 1-20: **Serial I/O Analyzer Links**

In Case of RX Bit Errors

If there are initial bit errors after linking, or as a result of changing the TX or RX pattern, click the respective **BERT Reset** button to zero the count.

If the **MGT Link Status** shows **No Link** for one or more transceivers:

- Make sure the blue elastomer seal is connected to the bottom of the Bulls Eye cable and the cable is firmly connected and flush on the board.
- Increase the TX differential swing of the transceiver (to compensate for any loss due to PCB process variation).
- Click the respective **TX Reset** button followed by **BERT Reset**.

Additional information on the Vivado Design Suite and IBERT core can be found in *Vivado Design Suite User Guide: Programming and Debugging* (UG908) [\[Ref 5\]](#).

Closing the IBERT Demonstration

To stop the IBERT demonstration:

1. Close the Vivado Design Suite by selecting **File > Exit**.
2. Place the main power switch SW1 in the OFF position.

Creating the GTH IBERT Core

Note: Vivado® Design Suite 2016.4 is required to rebuild the designs shown here.

This section provides a procedure to create a single Quad GTH IBERT core. The procedure assumes Quad 224 at 12.5 Gb/s line rate, but cores for any of the GTH Quads with any supported line rate can be created following the same series of steps.

For more details on generating IBERT cores, see the *Vivado Design Suite User Guide: Programming and Debugging* (UG908) [Ref 5].

1. Start the Vivado Design Suite.
2. In the Vivado Design Suite window, click **Manage IP** (highlighted in Figure 2-1) and select **New IP Location**.

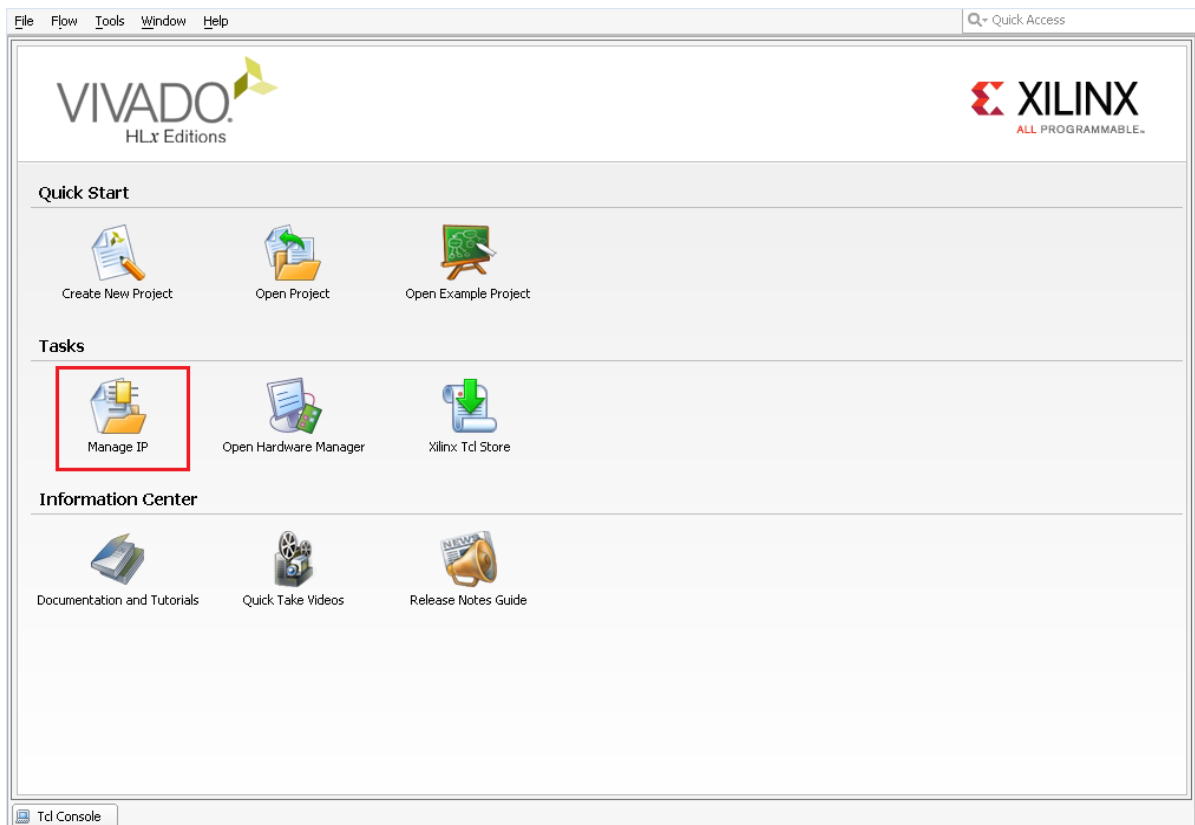

X16302-092916

Figure 2-1: Vivado Design Suite Initial Window

3. A **Create a New Customized IP Location** dialog window opens (not shown), Click **Next**.
4. In the **Manage IP Settings** window, select a part by clicking the (...) button next to the Part field. A **Select Device** window is displayed. Use the drop-down menu items to narrow the choices. Select the **xcku040-ffva1156-3-e** device (see [Figure 2-2](#)). Click **OK**.

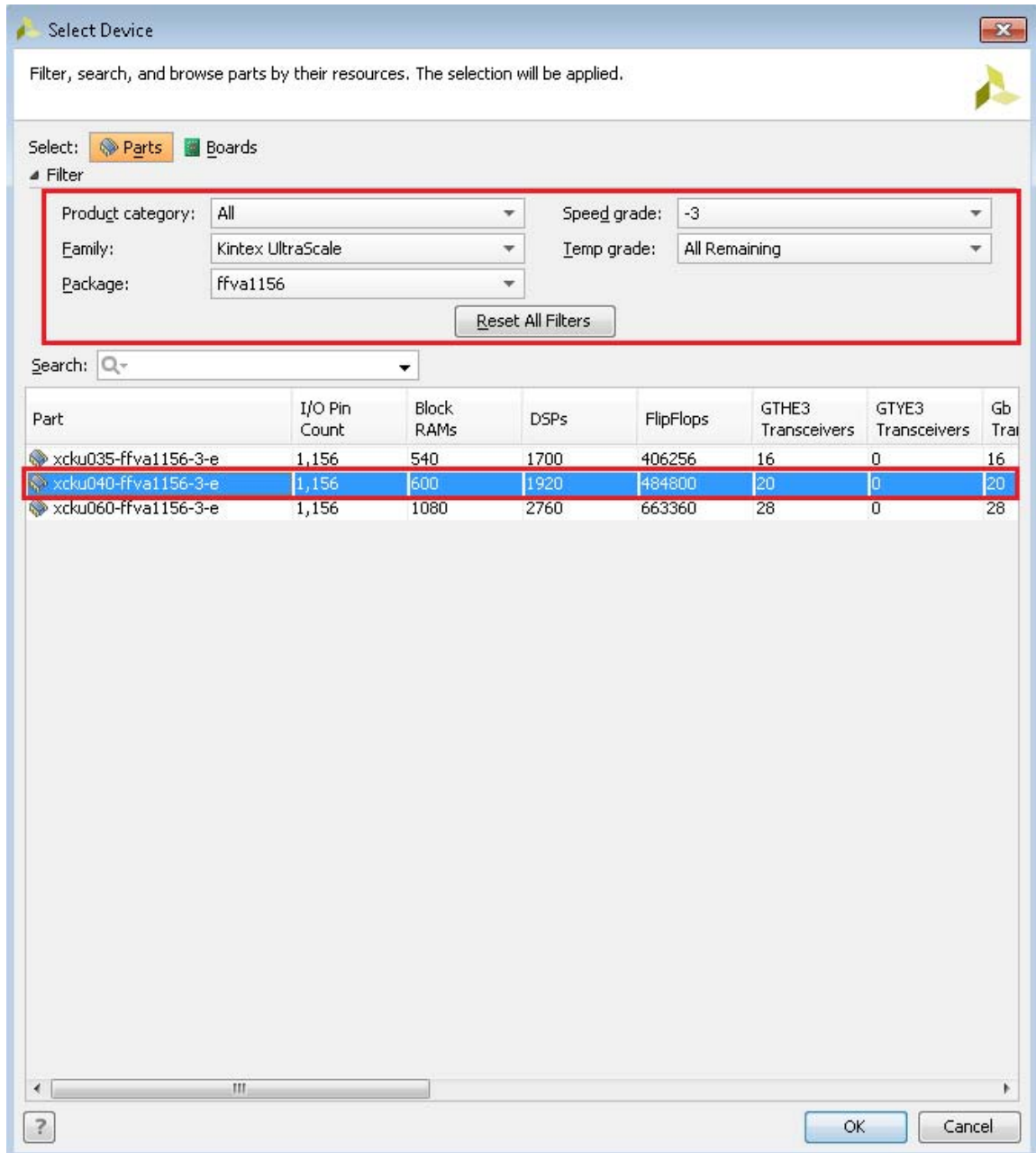

X16303-092916

Figure 2-2: Select Device

5. Back on the **Manage IP Catalog** window, select **Verilog** for Target language, **Vivado Simulator** for Target simulator, **Mixed** for Simulator language, and a directory to save the customized IP (Figure 2-3). Click **Finish**.

Note: Make sure the directory name does not include spaces.

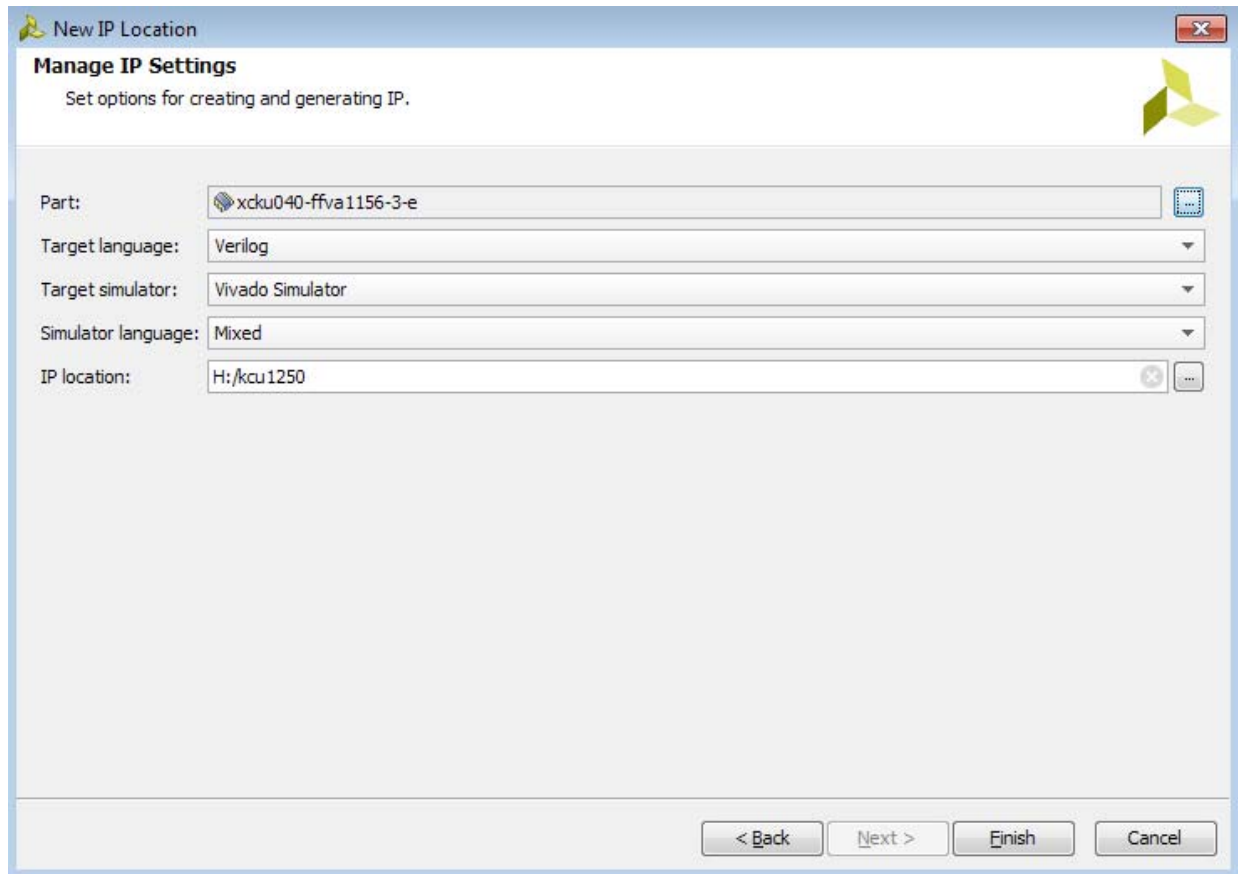

X16304-030416

Figure 2-3: Manage IP Settings

- In the **IP Catalog** window, expand the **Debug & Verification** folder, expand the **Debug** folder, and double-click **IBERT UltraScale GTH** (Figure 2-4).

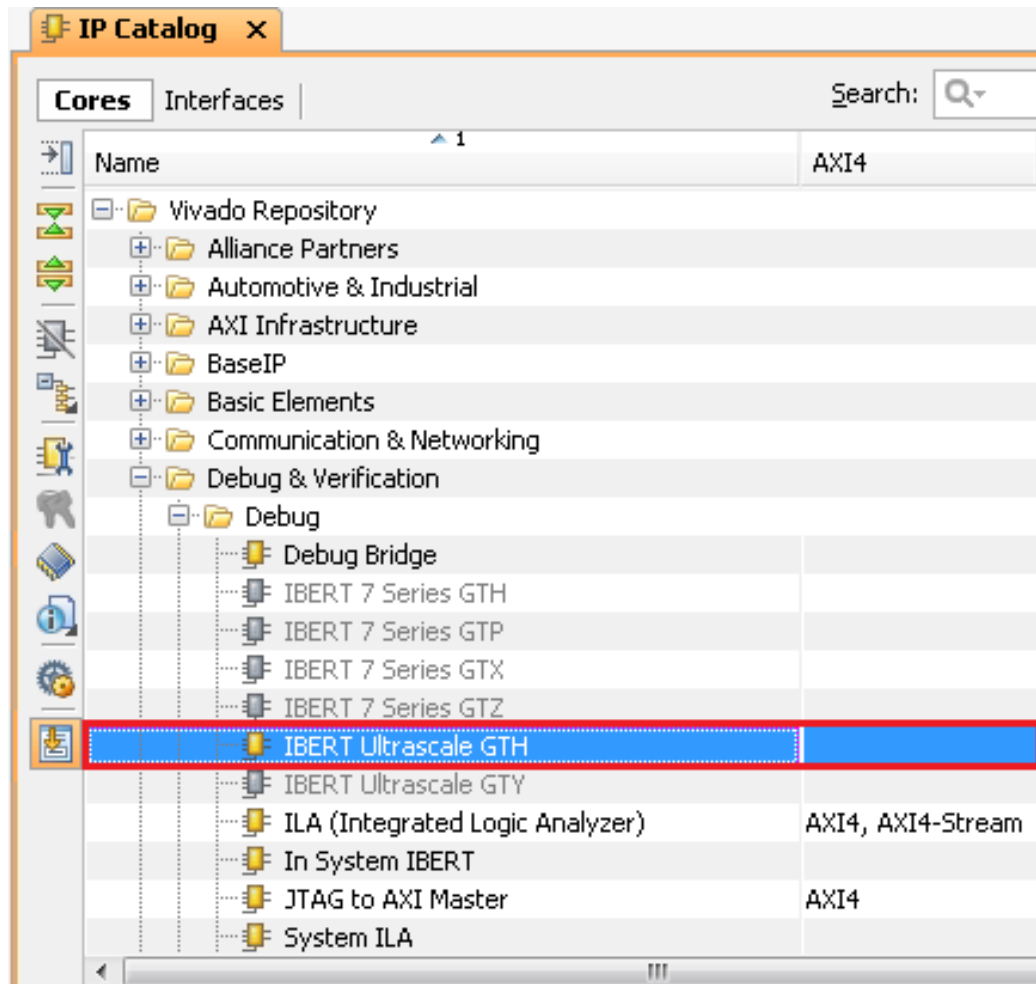

X16305-092916

Figure 2-4: IP Catalog

7. A **Customize IP** window opens. In the Protocol Definition tab, set the **LineRate (Gb/s)** to **12.5 Gbps**. Change **Refclk (MHz)** to 125. Keep defaults for other fields (Figure 2-5).

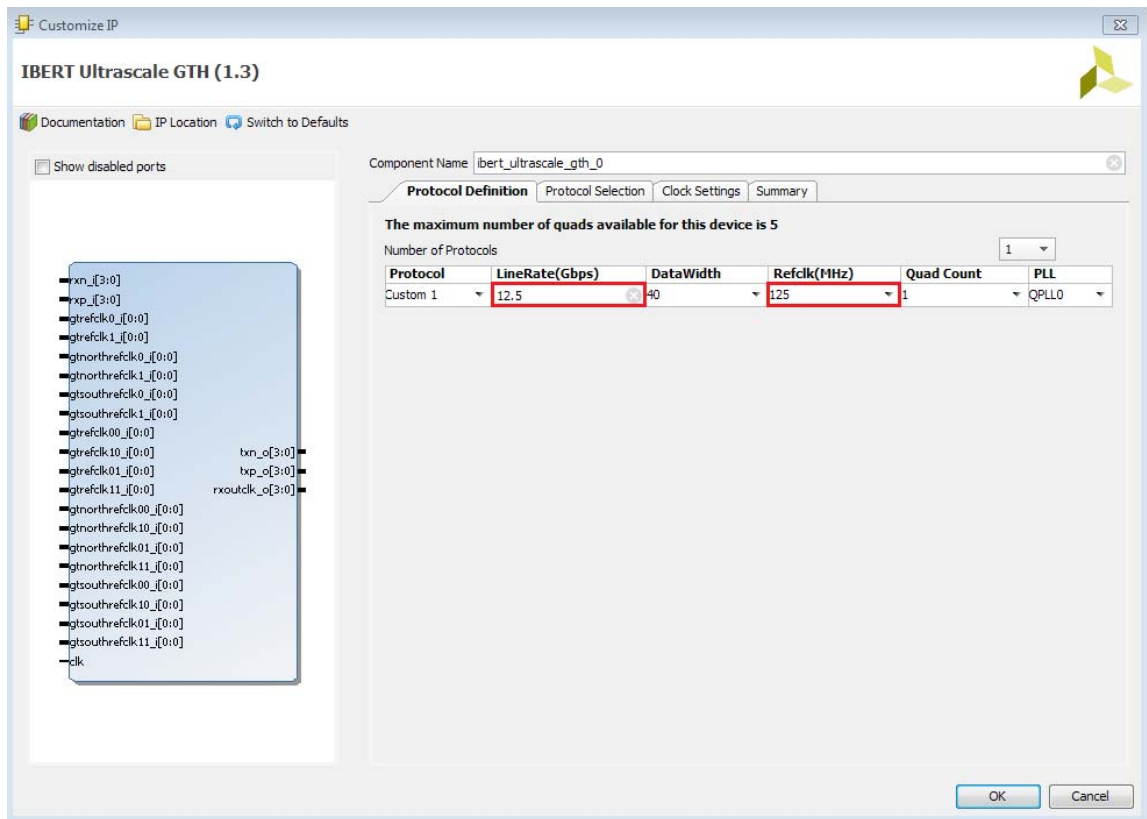

X16306-030416

Figure 2-5: Customize IP – Protocol Definition

- In the **Protocol Selection** tab, use the **Protocol Selected** drop-down menu next to QUAD_224 to select **Custom 1/12.5 Gb/s** (Figure 2-6).

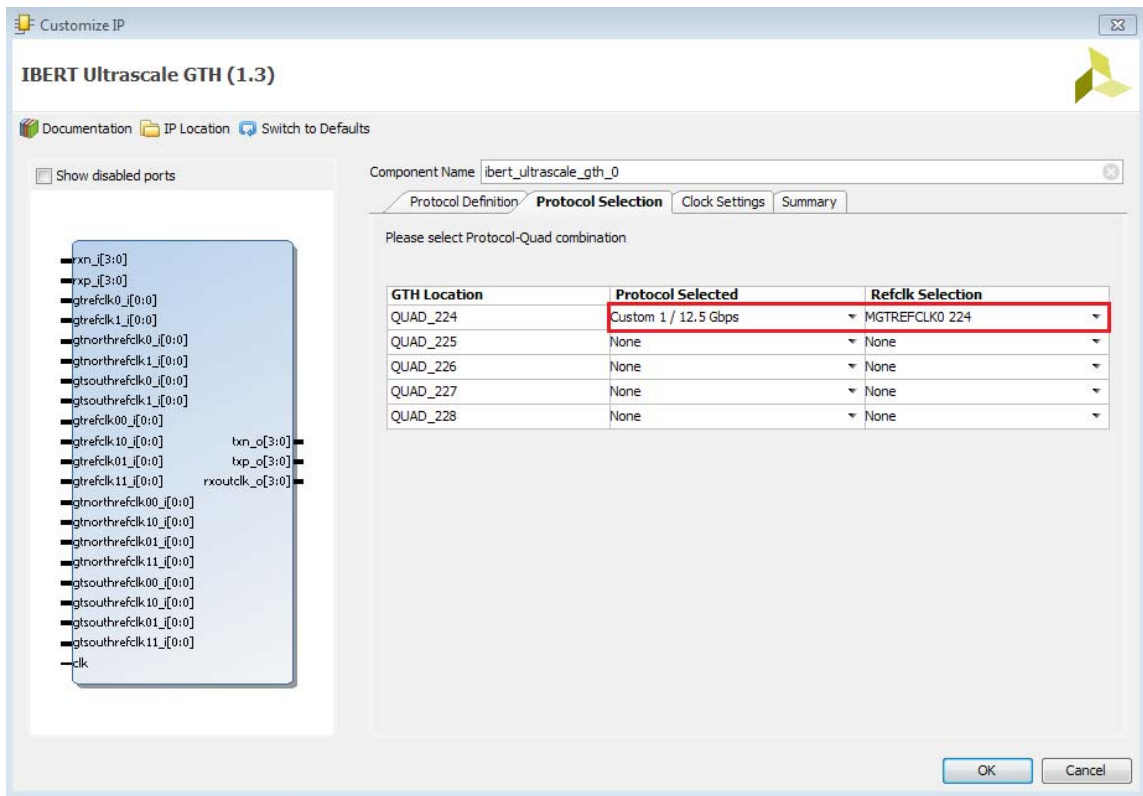

X16307-030416

Figure 2-6: Customize IP – Protocol Selection

- In the **Clock Settings** tab, select **DIFF SSTL15** for the I/O Standard, enter **E18** for the P Package Pin (the FPGA pins to which the system clock is connected), and make sure the **Frequency (MHz)** is set to **300** (Figure 2-7). Click **OK**. Click **Generate** in the next window to generate the output products.

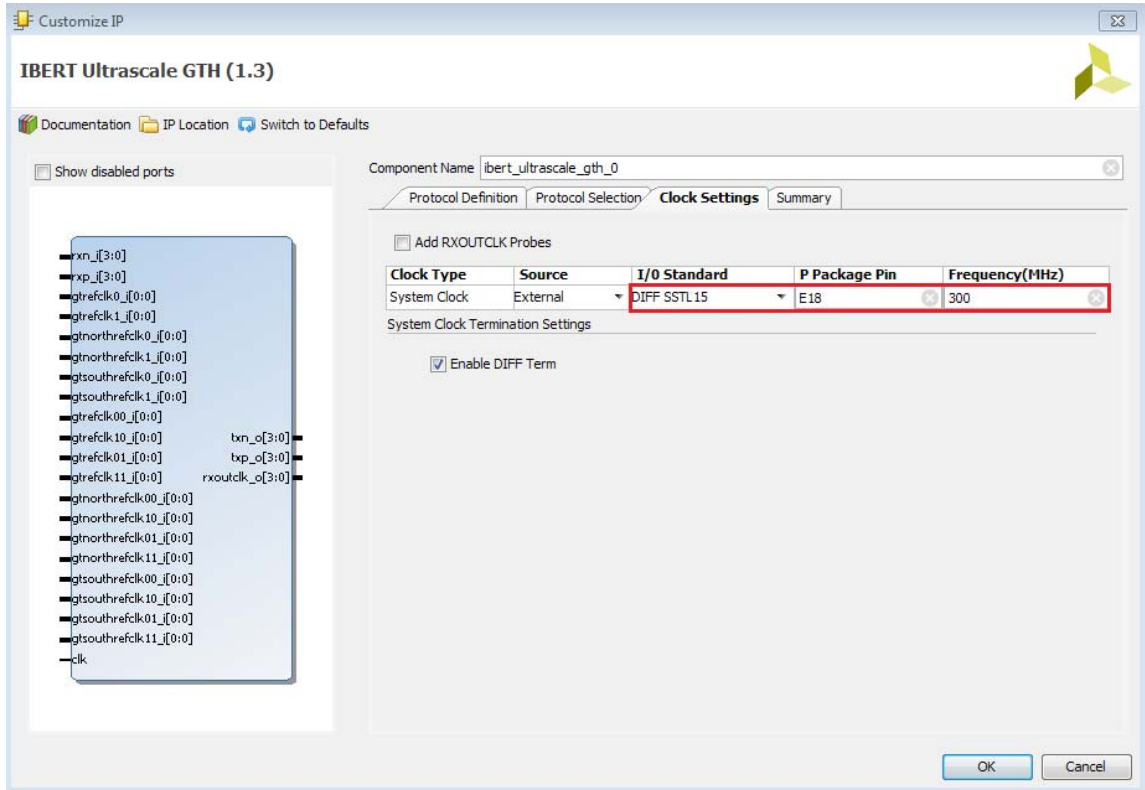

X16308-030416

Figure 2-7: Customize IP - Clock Settings

- Back on the **Manage IP Catalog** window, in the **Sources** window, right-click the **IBERT IP** and select **Open IP Example Design** (Figure 2-8). Specify a location to save the design, click **OK**, and the design opens in a new Vivado Design Suite window.

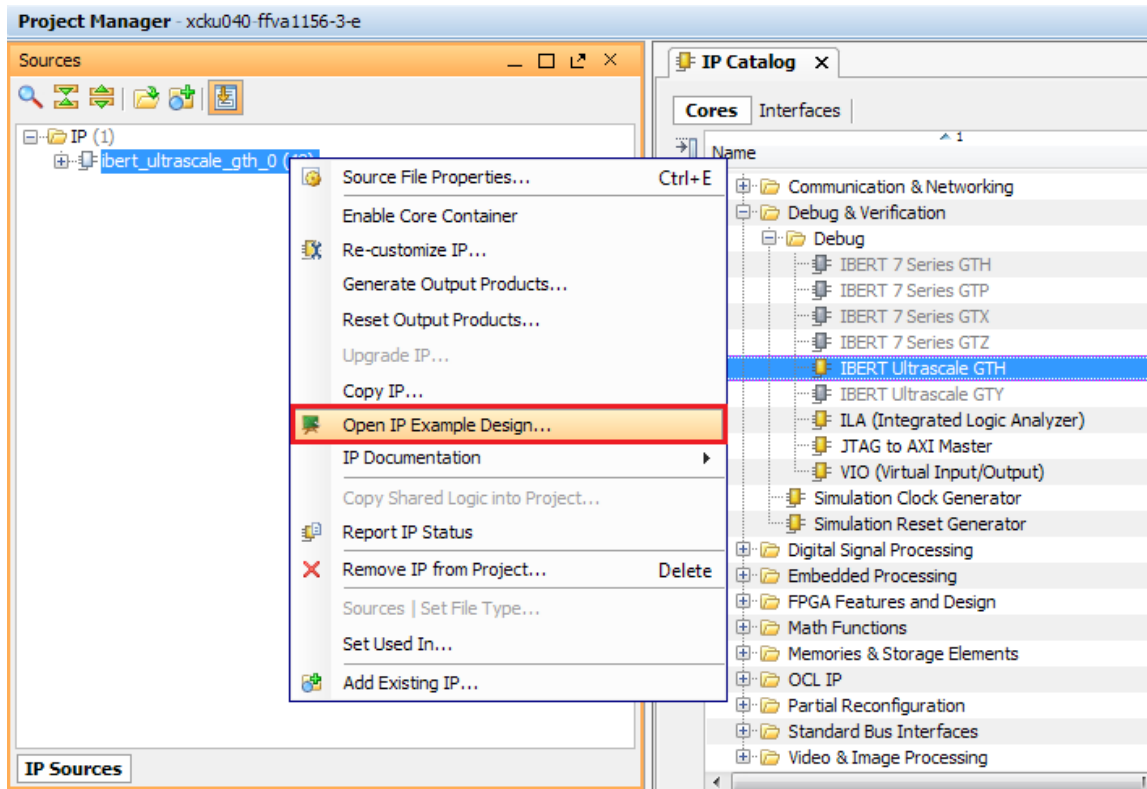

X16309-030416

Figure 2-8: Open IP Example Design

11. In the **Sources** window, Design Sources should now show the IBERT design example (Figure 2-9).

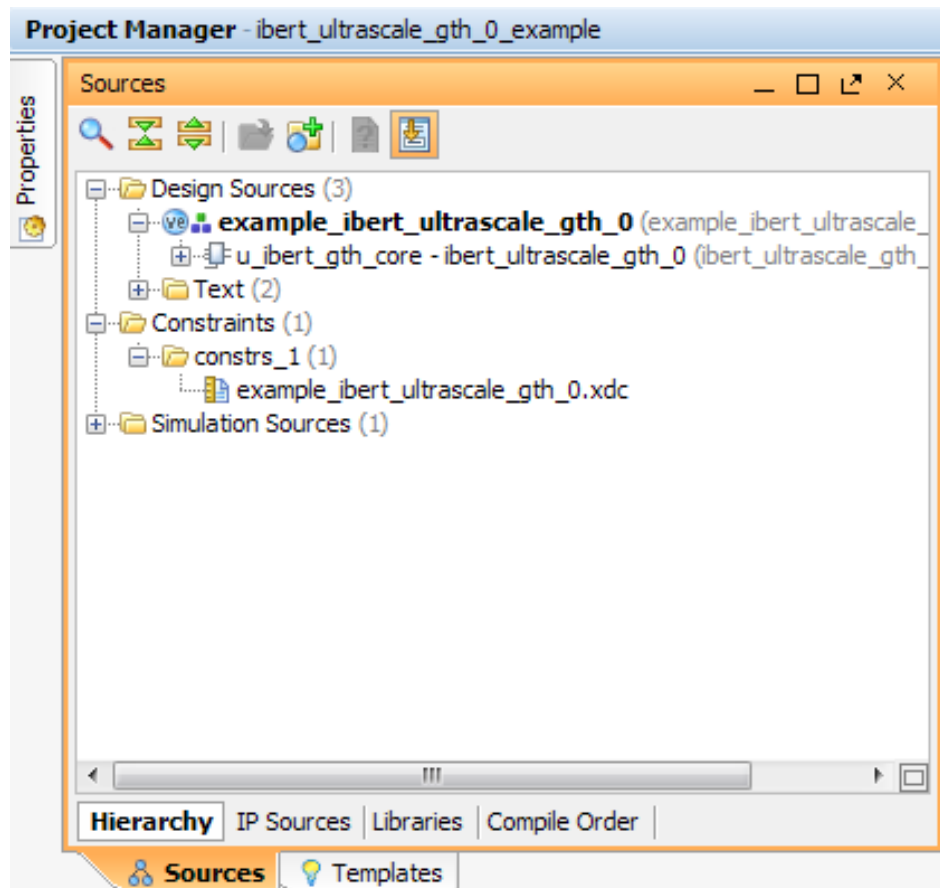

X16310-030416

Figure 2-9: Design Sources File Hierarchy

12. Click **Run Synthesis** from the **Flow Navigator** to synthesize the design (Figure 2-10).

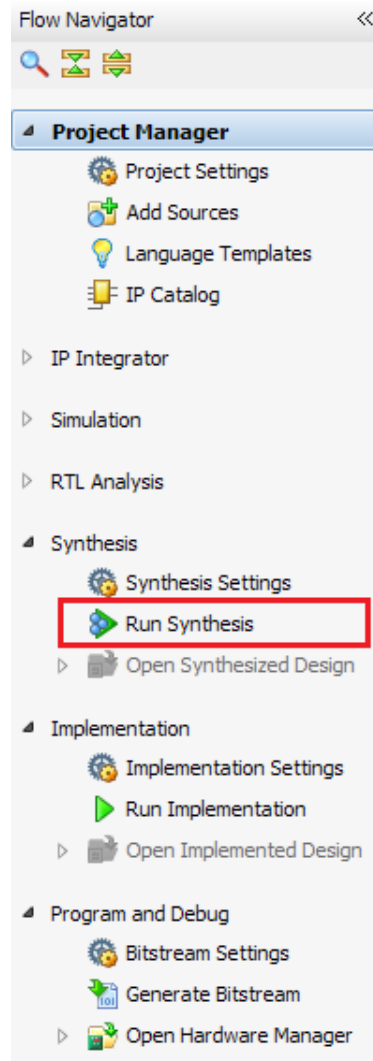

X16311-030416

Figure 2-10: Run Synthesis

13. When the synthesis is done, a **Synthesis Completed** window opens. Select **Run Implementation** and click **OK** (Figure 2-11).

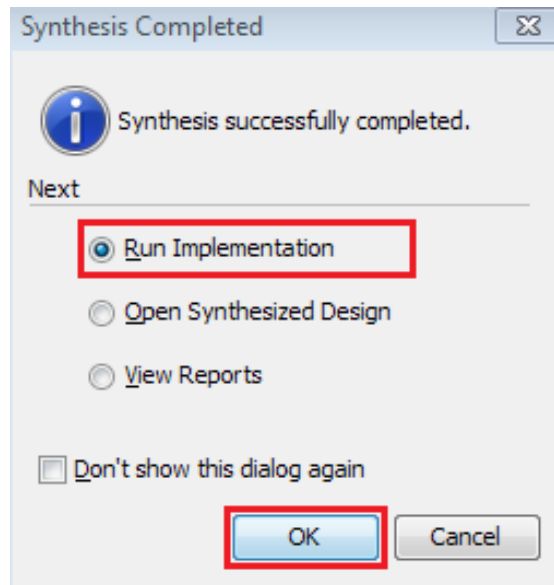

X16312-052716

Figure 2-11: Synthesis Completed

14. When the implementation is done, an **Implementation Completed** window opens. Select **Generate Bitstream** and click **OK** (Figure 2-12).

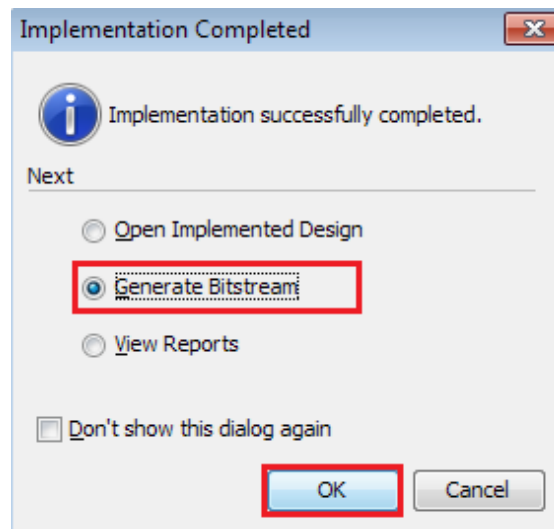

X16313-030416

Figure 2-12: Implementation Completed

- When the **Bitstream Generation Completed** dialog window appears, click **Cancel** (Figure 2-13).

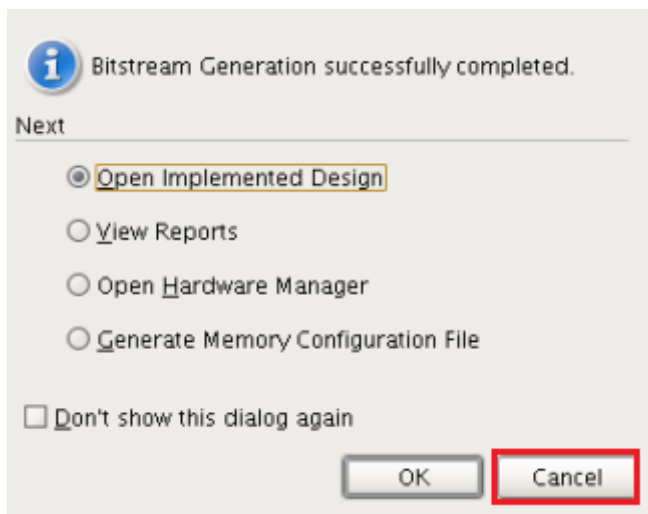

X16314-052716

Figure 2-13: Bitstream Generation Complete

- Navigate to the `...\ibert_ultrascale_gth_0_example\ibert_ultrascale_gth_0_example.runs\impl_1` directory to locate the generated bitstream.

Warranty

THIS LIMITED WARRANTY applies solely to standard hardware development boards and standard hardware programming cables manufactured by or on behalf of Xilinx ("Development Systems"). Subject to the limitations herein, Xilinx warrants that Development Systems, when delivered by Xilinx or its authorized distributor, for ninety (90) days following the delivery date, will be free from defects in material and workmanship and will substantially conform to Xilinx publicly available specifications for such products in effect at the time of delivery. This limited warranty excludes: (i) engineering samples or beta versions of Development Systems (which are provided "AS IS" without warranty); (ii) design defects or errors known as "errata"; (iii) Development Systems procured through unauthorized third parties; and (iv) Development Systems that have been subject to misuse, mishandling, accident, alteration, neglect, unauthorized repair or installation. Furthermore, this limited warranty shall not apply to the use of covered products in an application or environment that is not within Xilinx specifications or in the event of any act, error, neglect or default of Customer. For any breach by Xilinx of this limited warranty, the exclusive remedy of Customer and the sole liability of Xilinx shall be, at the option of Xilinx, to replace or repair the affected products, or to refund to Customer the price of the affected products. The availability of replacement products is subject to product discontinuation policies at Xilinx. Customer may not return product without first obtaining a customer return material authorization (RMA) number from Xilinx.

THE WARRANTIES SET FORTH HEREIN ARE EXCLUSIVE. XILINX DISCLAIMS ALL OTHER WARRANTIES, WHETHER EXPRESS, IMPLIED OR STATUTORY, INCLUDING, WITHOUT LIMITATION, ANY WARRANTY OF MERCHANTABILITY, FITNESS FOR A PARTICULAR PURPOSE, OR NON-INFRINGEMENT, AND ANY WARRANTY THAT MAY ARISE FROM COURSE OF DEALING, COURSE OF PERFORMANCE, OR USAGE OF TRADE. (2008.10)



Do not throw Xilinx products marked with the "crossed out wheeled bin" in the trash. Directive 2002/96/EC on waste electrical and electronic equipment (WEEE) requires the separate collection of WEEE. Your cooperation is essential in ensuring the proper management of WEEE and the protection of the environment and human health from potential effects arising from the presence of hazardous substances in WEEE. Return the marked products to Xilinx for proper disposal. Further information and instructions for free-of-charge return available at: www.xilinx.com/ehs/weee.htm.

Additional Resources and Legal Notices

Xilinx Resources

For support resources such as Answers, Documentation, Downloads, and Forums, see [Xilinx Support](#).

Solution Centers

See the [Xilinx Solution Centers](#) for support on devices, software tools, and intellectual property at all stages of the design cycle. Topics include design assistance, advisories, and troubleshooting tips.

References

The most up to date information related to the KCU1250 kit and its documentation is available on these websites.

[Kintex UltraScale FPGA KCU1250 Characterization Kit](#)

[Kintex UltraScale FPGA KCU1250 Characterization Kit documentation](#)

[Kintex UltraScale FPGA KCU1250 Characterization Kit Master Answer Record \(AR 63058\)](#)

These Xilinx documents provide supplemental material useful with this guide:

1. *KCU1250 Board User Guide* ([UG1057](#))
2. *HW-CLK-101-SCLK2 SuperClock-2 Module User Guide* ([UG770](#))
3. *Silicon Labs CP210x USB-to-UART Installation Guide* ([UG1033](#))
4. *UltraScale Architecture Configuration User Guide* ([UG570](#))
5. *Vivado Design Suite User Guide: Programming and Debugging* ([UG908](#))
6. *Kintex UltraScale FPGAs Data Sheet: DC and AC Switching Characteristics* ([DS892](#))

7. *Zynq-7000 All Programmable SoC Overview* ([DS190](#))
8. *UltraScale Architecture GTH Transceivers User Guide* ([UG576](#))
9. *Vivado Design Suite User Guide: Getting Started* ([UG910](#))
10. *Tera Term Terminal Emulator Installation Guide* ([UG1036](#))
11. *UltraScale FPGAs Transceivers Wizard LogiCORE IP Product Guide* ([PG182](#))

Please Read: Important Legal Notices

The information disclosed to you hereunder (the "Materials") is provided solely for the selection and use of Xilinx products. To the maximum extent permitted by applicable law: (1) Materials are made available "AS IS" and with all faults, Xilinx hereby DISCLAIMS ALL WARRANTIES AND CONDITIONS, EXPRESS, IMPLIED, OR STATUTORY, INCLUDING BUT NOT LIMITED TO WARRANTIES OF MERCHANTABILITY, NON-INFRINGEMENT, OR FITNESS FOR ANY PARTICULAR PURPOSE; and (2) Xilinx shall not be liable (whether in contract or tort, including negligence, or under any other theory of liability) for any loss or damage of any kind or nature related to, arising under, or in connection with, the Materials (including your use of the Materials), including for any direct, indirect, special, incidental, or consequential loss or damage (including loss of data, profits, goodwill, or any type of loss or damage suffered as a result of any action brought by a third party) even if such damage or loss was reasonably foreseeable or Xilinx had been advised of the possibility of the same. Xilinx assumes no obligation to correct any errors contained in the Materials or to notify you of updates to the Materials or to product specifications. You may not reproduce, modify, distribute, or publicly display the Materials without prior written consent. Certain products are subject to the terms and conditions of Xilinx's limited warranty, please refer to Xilinx's Terms of Sale which can be viewed at <https://www.xilinx.com/legal.htm#tos>; IP cores may be subject to warranty and support terms contained in a license issued to you by Xilinx. Xilinx products are not designed or intended to be fail-safe or for use in any application requiring fail-safe performance; you assume sole risk and liability for use of Xilinx products in such critical applications, please refer to Xilinx's Terms of Sale which can be viewed at <https://www.xilinx.com/legal.htm#tos>.

AUTOMOTIVE APPLICATIONS DISCLAIMER

AUTOMOTIVE PRODUCTS (IDENTIFIED AS "XA" IN THE PART NUMBER) ARE NOT WARRANTED FOR USE IN THE DEPLOYMENT OF AIRBAGS OR FOR USE IN APPLICATIONS THAT AFFECT CONTROL OF A VEHICLE ("SAFETY APPLICATION") UNLESS THERE IS A SAFETY CONCEPT OR REDUNDANCY FEATURE CONSISTENT WITH THE ISO 26262 AUTOMOTIVE SAFETY STANDARD ("SAFETY DESIGN"). CUSTOMER SHALL, PRIOR TO USING OR DISTRIBUTING ANY SYSTEMS THAT INCORPORATE PRODUCTS, THOROUGHLY TEST SUCH SYSTEMS FOR SAFETY PURPOSES. USE OF PRODUCTS IN A SAFETY APPLICATION WITHOUT A SAFETY DESIGN IS FULLY AT THE RISK OF CUSTOMER, SUBJECT ONLY TO APPLICABLE LAWS AND REGULATIONS GOVERNING LIMITATIONS ON PRODUCT LIABILITY.

© Copyright 2015–2016 Xilinx, Inc. Xilinx, the Xilinx logo, Artix, ISE, Kintex, Spartan, Virtex, Vivado, Zynq, and other designated brands included herein are trademarks of Xilinx in the United States and other countries. All other trademarks are the property of their respective owners.