



XAPP1076 (v1.0) December 15, 2010

# Implementing Triple-Rate SDI with Spartan-6 FPGA GTP Transceivers

Author: Reed Tidwell

## Summary

The triple-rate serial digital interface (SDI) supporting the SMPTE SD-SDI, HD-SDI, and 3G-SDI standards is widely used in professional broadcast video equipment. SDI interfaces are used in broadcast studios and video production centers to carry uncompressed digital video, along with embedded ancillary data, such as multiple audio channels.

Spartan®-6 FPGA GTP transceivers are well-suited for implementing triple-rate SDI receivers and transmitters. This document describes how to implement triple-rate SDI interfaces using Spartan-6 FPGAs.

## Introduction

The Spartan-6 FPGA triple-rate SDI reference design supports SD-SDI, HD-SDI, and 3G-SDI (both level A and level B). If an application only requires support for a subset of these SDI standards, the triple-rate SDI interface is still used. There is little overhead in the basic triple-rate SDI datapath for the unused SDI standards.

### Differences from Virtex-5 FPGA GTP Transceivers

The GTP transceivers in Spartan-6 devices are similar to the GTP transceivers in Virtex®-5 LXT devices. The differences important to SDI interfaces are described in this section.

Virtex-5 FPGA GTP transceivers come in GTP\_DUAL tiles, with one PMA PLL (used for reference clock multiplication) shared by the two transmitters and two receivers in the tile. The shared PMA PLL limits the independence of the receivers and transmitters in the tile. Spartan-6 FPGA GTP transceivers also come in GTP\_DUAL tiles; however, Spartan-6 FPGA GTP transceivers have a separate PMA PLL available for each lane (receiver/transmitter pair). This provides two independent clocks that are shared by the transmitters and receivers in the tile. This allows more flexibility in using a tile for both transmitting and receiving; however, it is still not recommended to use a transmitter and receiver with a common clock, unless the reference clock does not change. The receivers should use a different clock from the transmitters because if the transmitter clock changes, the receiver stream incurs errors. It is possible, in Spartan-6 devices, to have transmitters in the same tile transmitting at different bit rates, something that was impossible in Virtex-5 devices because of the single PMA PLL.

The clock recovered by a Virtex-5 FPGA GTP receiver stops if the input serial bitstream stops. This situation often requires using a BUFGMUX to substitute a free-running clock for the recovered clock when it stops, because many video applications cannot tolerate a stoppage in the recovered video clock. The recovered clocks from Spartan-6 FPGA GTP receivers do not stop when the input bitstream stops. This eliminates the need to use BUFGMUXes to swap in a free-running clock.

In GTP\_DUAL tiles of Virtex-5 FPGA GTP transceivers, the reference clock provided to the PMA PLL could be changed dynamically, but only through the DRP port. The reference clock multiplexer for each PMA PLL in the Spartan-6 FPGA GTP transceiver is dynamically controlled by reference clock selection ports, rather than through the DRP.

The Virtex-5 FPGA GTP receiver requires a clock and data recovery (CDR) reset when the input bitstream stops, such as when the SDI cable is unplugged. The preferred method to

generate this reset in SDI interfaces is to use the carrier detect signal from the SDI cable equalizer. The Spartan-6 FPGA GTP receiver does not require the carrier detect signal from the SDI cable equalizer to generate a CDR reset when the cable is unplugged.

In Virtex-5 FPGA GTP transceivers, the fundamental user clock frequency is at a two word per clock rate. For SDI, this means the user clock rate is 1/20th the serial bit rate. In the Spartan-6 FPGA GTP transceiver, the user clock frequency is one word per clock. For SDI, that means 1/10th the serial bit rate. The GTP transceiver uses a 20-bit parallel interface. Thus, two clocks must be provided to the GTP transceiver: USRCLK at 1/10th the serial bit rate, and USRCLK2 at 1/20th the serial bit rate.

The slowest speed grade, -2, of Spartan-6 devices does not support the 20-bit interface at the speed required for 3G-SDI and oversampled SD-SDI. Therefore, the reference design described in this application note can only be implemented on speed grades of -3 or faster.

## Supported Video Formats

The triple-rate SDI receiver and transmitter support the video formats shown in [Table 1](#). The receiver and transmitter do not convert between video and SDI data streams for all video formats. The formats that require conversion between SDI data streams and video using external formatting modules are marked as *External* in the SDI Stream Mapping column. Those that are directly supported are marked with Not required in the SDI Stream Mapping column.

Table 1: Supported Video Formats

| Interface                     | Video Standard     | Sampling Structure/<br>Bit Depth              | Frame/Field Rate (Hz)  | SDI Stream Mapping |
|-------------------------------|--------------------|---|--|--------------------|
| SD-SDI<br>SMPTE 259-C         | PAL                | 4:2:2 Y'Cb'Cr' 10-bit or 8-bit                | 50   | Not required       |
|                               | NTSC               | 4:2:2 Y'Cb'Cr' 10-bit or 8-bit                | 59.94  | Not required       |
| HD-SDI<br>SMPTE 292           | SMPTE 274          | 4:2:2 Y'Cb'Cr' 10-bit                         | 1080p: 23.98, 24, 25, 29.97, 30<br>1080i: 50, 59.94, 60<br>1080PsF: 23.98, 24, 25, 29.97, 30 | Not required       |
|                               | SMPTE 296          | 4:2:2 Y'Cb'Cr' 10-bit                         | 720p: 23.98, 24, 25, 29.97, 30, 50,<br>59.94, 60   | Not required       |
|                               | SMPTE 260          | 4:2:2 Y'Cb'Cr' 10-bit                         | 1035i: 59.94, 60   | Not required       |
|                               | SMPTE 295          | 4:2:2 Y'Cb'Cr' 10-bit                         | 1080i: 50  | Not required       |
| 3G-SDI Level A<br>SMPTE 425-A | SMPTE 274          | 4:2:2 Y'Cb'Cr' 10-bit                         | 1080p: 50, 59.94, 60   | Not required       |
|                               |                    | 4:4:4 or 4:4:4:4 Y'Cb'Cr'<br>or<br>RGB 10-bit | 1080p: 23.98, 24, 25, 29.97, 30<br>1080i: 50, 59.94, 60<br>1080PsF: 23.98, 24, 25, 29.97, 30 | External           |
|                               |                    | 4:4:4 Y'Cb'Cr' or RGB 12-bit                  | 1080p: 23.98, 24, 25, 29.97, 30<br>1080i: 50, 59.94, 60<br>1080PsF: 23.98, 24, 25, 29.97, 30 | External           |
|                               |                    | 4:2:2 Y'Cb'Cr' 12-bit                         | 1080p: 23.98, 24, 25, 29.97, 30<br>1080i: 50, 59.94, 60<br>1080PsF: 23.98, 24, 25, 29.97, 30 | External           |
|                               | SMPTE 296          | 4:4:4 or 4:4:4:4 Y'Cb'Cr'<br>or<br>RGB 10-bit | 720p: 23.98, 24, 25, 29.97, 30, 50,<br>59.94, 60   | External           |
|                               | SMPTE 428-9        | 4:4:4 X'Y'Z' 12-bit                           | 2048 x 1080p: 24   | External           |
| 3G-SDI Level B<br>SMPTE 425-B | SMPTE 372          | See Dual-Link HD-SDI SMPTE 372 in this table. |  |                    |
|                               | 2 X HD-SDI streams | See HD-SDI SMPTE 292 in this table.           |  |                    |
| Dual-Link HD-SDI<br>SMPTE 372 | SMPTE 274          | 4:2:2 Y'Cb'Cr' 10-bit                         | 1080p: 50, 59.94, 60   | External           |
|                               |                    | 4:4:4 or 4:4:4:4 Y'Cb'Cr'<br>or<br>RGB 10-bit | 1080p: 23.98, 24, 25, 29.97, 30<br>1080i: 50, 59.94, 60<br>1080PsF: 23.98, 24, 25, 29.97, 30 | External           |
|                               |                    | 4:4:4 Y'Cb'Cr' or RGB 12-bit                  | 1080p: 23.98, 24, 25, 29.97, 30<br>1080i: 50, 59.94, 60<br>1080PsF: 23.98, 24, 25, 29.97, 30 | External           |
|                               |                    | 4:2:2 Y'Cb'Cr' 12-bit                         | 1080p: 23.98, 24, 25, 29.97, 30<br>1080i: 50, 59.94, 60<br>1080PsF: 23.98, 24, 25, 29.97, 30 | External           |
|                               | SMPTE 428-9        | 4:4:4 X'Y'Z' 12-bit                           | 2048 x 1080p: 24   | External           |

# Triple-Rate SDI Receiver Reference Design

A triple-rate SDI receiver is implemented by an `s6_sdi_rx_light_20b` module, combined with a Spartan-6 FPGA GTP receiver and an `s6gtp_sdi_control` module, as shown in Figure 1. Optionally, an EDH processor can be included to provide SD-SDI error checking and lock-detection features.

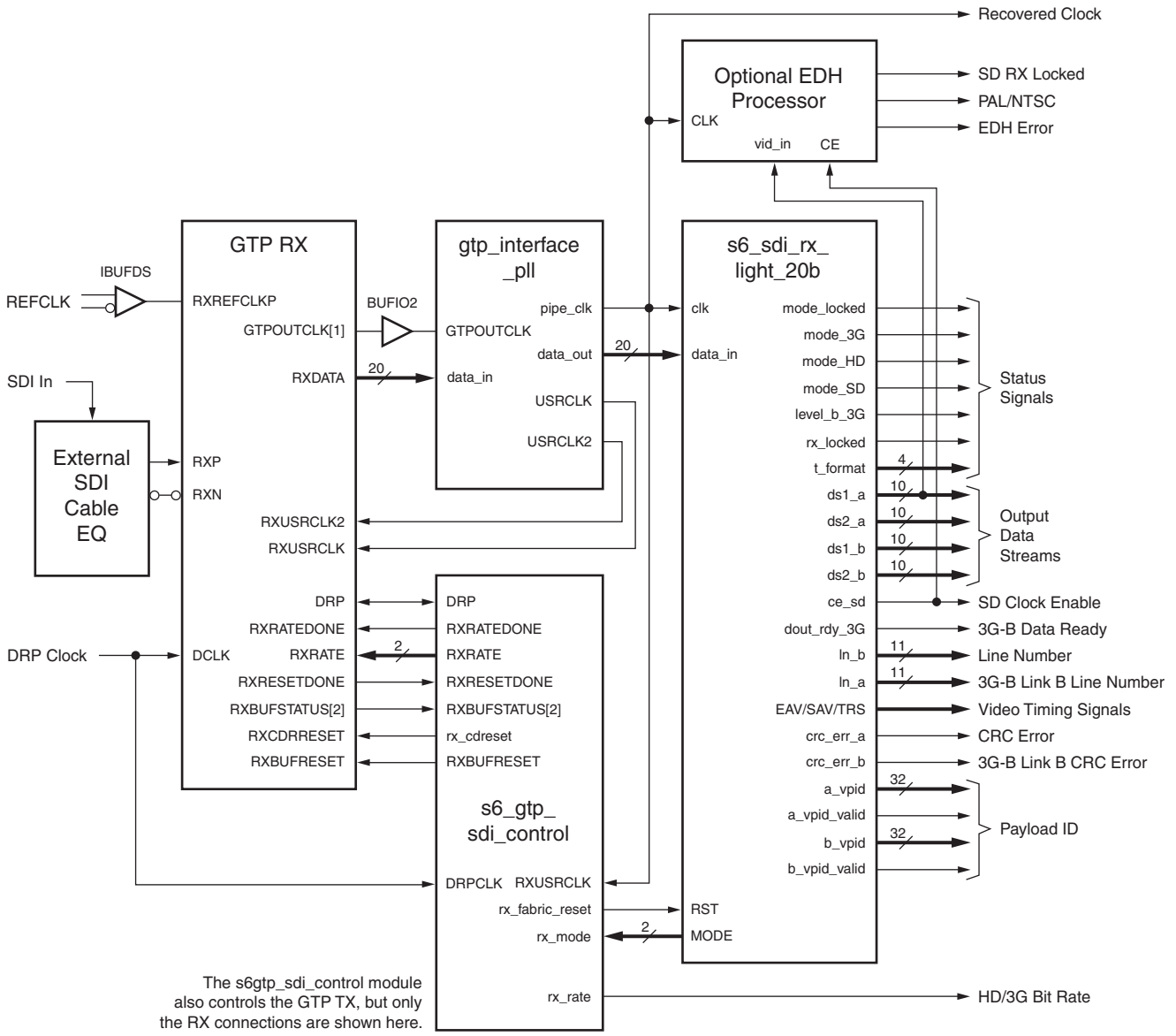

X1076\_01\_120210

Figure 1: Spartan-6 FPGA GTP Transceiver Triple-Rate SDI Receiver Block Diagram

The triple-rate SDI receiver has these features:

- Uses a 20-bit GTP transceiver interface, supported on -3 and faster Spartan-6 devices
- A single reference clock frequency is required to receive the five supported bit rates:
  - 270 Mb/s SD-SDI (SMPTE 259)
  - 1.485 Gb/s HD-SDI (SMPTE 292)
  - 148.5/1.001 Gb/s HD-SDI (SMPTE 292)
  - 2.97 Gb/s 3G-SDI (SMPTE 424)
  - 2.97/1.001 Gb/s 3G-SDI (SMPTE 424)

- The receiver has a bit rate detector that can distinguish between the two HD-SDI and two 3G-SDI bit rates. An output signal from the receiver indicates which bit rate is being received.
- The receiver automatically detects the SDI standard of the input signal (3G-SDI, HD-SDI, or SD-SDI) and reports the current SDI mode on an output port.
- The receiver detects and reports the video transport format (e.g., 1080p 30 Hz, 1080i 50 Hz).
- The receiver supports both 3G-SDI level A and level B formats, and automatically detects whether 3G-SDI data streams are level A or B. The 3G-SDI level is reported on an output port.
- The receiver performs CRC error checking for HD-SDI and 3G-SDI modes.
- Optional EDH error checking for SD-SDI is available.
- Line numbers are captured and output from the triple-rate SDI receiver. For 3G-SDI level B format, line numbers are captured for each of the two HD-SDI streams carried on the 3G-SDI interface.
- SMPTE 352 video payload ID packets are captured for all SDI modes. All captured SMPTE 352 packet data is available on output ports for one or two streams (for those formats that require SMPTE 352 packets in both streams).
- The pipeline clock and the GTP transceiver user clocks are created in the GTP interface module.
- All ancillary data embedded in the SDI data streams is preserved and output from the receiver on the video data stream outputs.

Table 2 describes the I/O ports of the `s6_sdi_rx_light_20b` module.

Table 2: I/O Ports of the `s6_sdi_rx_light_20b` Module

| Port Name | I/O | Width     | Description   |
|-----------|-----|-----------|---|
| clk       | In  | 1         | The user connects this clock input to the <code>pipe_clk</code> output of the <code>gtp_interface_pll</code> module for the GTP RX. The clock frequency is 148.5 MHz (or 148.5/1.001 MHz) for 3G-SDI, and 74.25 MHz (or 74.25/1.001 MHz) for HD-SDI and SD-SDI.   |
| rst       | In  | 1         | This is an asserted High asynchronous reset input. The falling edge of this reset signal must meet the reset recovery time of all flip-flops relative to the next rising edge of <code>clk</code> . Usually, this input can be tied to ground because a reset is not required. After FPGA configuration, this module is in a fully operational mode.  |
| data_in   | In  | 20        | The user connects this port to the <code>data_out_20</code> port of the <code>gtp_interface_pll</code> module.  |
| frame_en  | In  | 1         | This input enables the SDI framer function. When this input is High, the framer automatically readjusts the output word alignment to match the alignment of each timing reference signal (TRS), EAV or SAV. Normally, this input should always be High. However, if controlled properly, this input can be used to implement TRS alignment filtering. For example, if the <code>nsp</code> output is connected to the <code>frame_en</code> input, the framer ignores a single misaligned TRS, keeping the existing word alignment until the new word alignment is confirmed by a second matching TRS. It is important to turn off any TRS filtering during the synchronous switching lines by driving the <code>frame_en</code> input High on the synchronous switching lines. |
| ce_sd     | Out | NUM_SD_CE | This output port consists of NUM_SD_CE identical copies of the clock enable signal generated by the SD-SDI data recovery unit in SD-SDI mode. In SD-SDI mode, this output is asserted at a 27 MHz rate. In HD-SDI and 3G-SDI modes, this output is always High.   |

Table 2: I/O Ports of the s6\_sdi\_rx\_light\_20b Module (Cont'd)

| Port Name                     | I/O | Width | Description   |
|-------------------------------|-----|-------|---|
| mode                          | Out | 2     | <p>This output port indicates the current SDI mode of the receiver:</p> <ul style="list-style-type: none"> <li>• 00 = HD-SDI</li> <li>• 01 = SD-SDI</li> <li>• 10 = 3G-SDI</li> </ul> <p>When the receiver is not locked, the mode port changes values as the receiver searches for the correct SDI mode. During this time, the mode_locked output is Low. When the receiver detects the correct SDI mode, the mode_locked output goes High.</p> <p>This output port must be connected to the s6gtp_sdi_control module's rx_mode input.</p>   |
| mode_HD<br>mode_SD<br>mode_3G | Out | 1     | <p>These three output ports are decoded versions of the mode port. They are provided for convenience. Unlike the mode port, which changes continuously as the receiver seeks to identify and lock to the incoming signal, these outputs are all forced Low when the receiver is not locked. The mode output matching the current SDI mode of the receiver is High when mode_locked is High.</p>   |
| mode_locked                   | Out | 1     | <p>When this output is Low, the receiver is actively searching for the SDI mode that matches the input data stream. During this time, the mode output port changes frequently. When the receiver locks to the correct SDI mode, the mode_locked output goes High.</p>   |
| t_format                      | Out | 4     | <p>This output port indicates the video transport timing format of the SDI signal in HD and 3G modes only. Refer to <a href="#">Table 3, page 8</a> for encoding. The output port is only valid when rx_locked is High. This output port is not valid in SD-SDI mode.</p>   |
| rx_locked                     | Out | 1     | <p>This output is High when the receiver is locked to the incoming signal. In HD-SDI and 3G-SDI modes, this output is driven by the transport format detector that generates the t_format output. In SD-SDI mode, this output is identical to the mode_locked signal. Because this output is driven by the transport format detector in HD-SDI and 3G-SDI modes, there can be more than one video frame time of delay from when the receiver is actually locked to the input signal until rx_locked is asserted. During this time, the transport format detector determines the transport format.</p>                           |
| nsp                           | Out | 1     | <p>When this output is High, the framer has detected a TRS at a new word alignment. If frame_en is High, this output is only asserted briefly. If frame_en is Low, this output remains High until the framer is allowed to readjust to the new TRS alignment (by asserting frame_en High during the occurrence of a TRS).</p>   |
| ln_a                          | Out | 11    | <p>The current line number captured from the LN words of the Y data stream is output on this port. This output is valid in HD-SDI and 3G-SDI modes, but not in SD-SDI mode. In 3G-SDI level B mode, the output value is the line number from the Y data stream of link A or HD-SDI signal 1. For any case where the interface line number is not the same as the picture line number, such as for 1080p 60 Hz carried on 3G-SDI level B or dual-link HD-SDI, the output value is the interface line number, not the picture line number.</p>  |
| a_vpid                        | Out | 32    | <p>All four user data bytes of the SMPTE 352 packet from data stream 1 are output on this port in this format: most-significant byte to least-significant byte – byte4, byte3, byte2, byte1. This output port is valid only when a_vpid_valid is High. This port is potentially valid in any SDI mode, if there are SMPTE 352 packets embedded in the SDI signal. In 3G-SDI level A mode, the output data is the VPID data captured from data stream 1 (luma). In 3G-SDI level B mode, the output data is the VPID data captured from data stream 1 of link A (dual-link streams) or HD-SDI signal 1 (dual HD-SDI signals).</p> |
| a_vpid_valid                  | Out | 1     | <p>This output is High when a_vpid is valid.</p>  |

Table 2: I/O Ports of the s6\_sdi\_rx\_light\_20b Module (Cont'd)

| Port Name                                       | I/O | Width       | Description  |
|---|-----|-------------|--|
| b_vpid  | Out | 32          | All four user data bytes of the SMPTE 352 packet from data stream 2 are output on this port in this format: most-significant byte to least-significant byte – byte4, byte3, byte2, byte1. This output is valid only in 3G-SDI mode and only when b_vpid_valid is High. In 3G-SDI level A mode, the output data is the VPID data captured from data stream 2 (chroma). In 3G-SDI level B mode, the output data is the VPID data captured from data stream 1 of link B (dual-link streams) or HD-SDI signal 2 (dual HD-SDI signals). |
| b_vpid_valid                                    | Out | 1           | This output is High when b_vpid is valid.  |
| crc_err_a                                       | Out | 1           | This output is asserted High for one sample period when a CRC error is detected on the previous video line. For 3G-SDI level B mode, this output indicates CRC errors on data stream 1 only. There is a second output called crc_err2 that indicates CRC errors on data stream 2 for 3G-SDI level B mode. This output is not valid in SD-SDI mode. The crc_err_a output is asserted High for a single clock cycle when a CRC error is detected.  |
| ds1_a   | Out | 10          | The recovered data stream 1 is output on this port. The contents of this data stream are dependent on the SDI mode: <ul style="list-style-type: none"> <li>• SD-SDI: Multiplexed Y/C data stream</li> <li>• HD-SDI: Y data stream</li> <li>• 3G-SDI level A: Data stream 1</li> <li>• 3G-SDI level B: Data stream 1 of link A or of HD-SDI signal 1</li> </ul>   |
| ds2_a   | Out | 10          | The recovered data stream 2 is output on this port. The contents of this data stream are dependent on the SDI mode: <ul style="list-style-type: none"> <li>• SD-SDI: Not used</li> <li>• HD-SDI: C data stream</li> <li>• 3G-SDI level A: Data stream 2</li> <li>• 3G-SDI level B: Data stream 2 of link A or of HD-SDI signal 1</li> </ul>  |
| eav   | Out | 1           | This output is asserted High for one sample time when the XYZ word of an EAV is present on the data stream output ports.   |
| sav   | Out | 1           | This output is asserted High for one sample time when the XYZ word of an SAV is present on the data stream output ports.   |
| trs   | Out | 1           | This output is asserted High for four consecutive sample times because all four words of an EAV or SAV are output on the data stream ports.  |
| <b>Outputs Used Only in 3G-SDI Level B Mode</b> |     |             |  |
| dout_rdy_3G                                     | Out | NUM_3G_DRDY | In 3G-SDI level B mode, the output data rate is 74.25 MHz, but the clock frequency is 148.5 MHz. The dout_rdy_3G outputs are asserted at a 74.25 MHz rate in 3G-SDI level B mode. This output is always High in all other modes, allowing it to be used as a clock enable to downstream modules.   |
| level_b_3G                                      | Out | 1           | In 3G-SDI mode, this output is asserted High when the input signal is level B and Low when it is level A.  |
| ds1_b   | Out | 10          | In 3G-SDI mode, the recovered data stream 1 of link B or of HD-SDI signal 2 is output on this port.  |
| ds2_b   | Out | 10          | In 3G-SDI mode, the recovered data stream 2 of link B or of HD-SDI signal 2 is output on this port.  |
| crc_err_b                                       | Out | 1           | This output is the CRC error indicator for link B or HD-SDI signal 2. The crc_err_b output is asserted High for a single clock cycle when a CRC error is detected.   |
| ln_b  | Out | 11          | This output port is only valid in 3G-SDI level B mode. It outputs the line number for the Y data stream of link B or the HD-SDI signal 2. For any case where the interface line number is not the same as the picture line number, the line number output on this port is the interface line number, not the picture line number.  |

Table 3 shows the encoding of the `t_format` output port. This port indicates the transport format (not always the same as the picture format) calculated by the receiver by counting words per line and active lines per field or frame. The `t_format` port can uniquely identify most video transport formats, but cannot distinguish between transport formats that have identical timing. For example, it cannot differentiate between 1080i 60 Hz and 1080PsF 30 Hz (1080p 30 Hz video carried on a 1080i 60 Hz transport) because there is no difference in the transport timing.

In dual-link HD-SDI and 3G-SDI level B modes, the 1080p 50 and 60 Hz video formats are carried on an interlaced transport. The module reports them as being 1080i 50 Hz and 1080i 60 Hz, respectively. However, in 3G-SDI level A mode, these two video formats are carried progressively and are uniquely identified as 1080p 50 Hz and 1080p 60 Hz (codes 1110 and 1101, respectively).

The transport format detector does not distinguish between frame rates that are 1000 ppm different, such as 1080p 60 Hz and 1080p 59.94 Hz. However, the `rx_rate` output of the `s6gtp_sdi_control` module can be used to distinguish between these otherwise identical frame rates.

Table 3: `t_format` Output Port Encoding for the `s6_sdi_rx_light_20b` Module

| <code>t_format</code> | Standard   | Video Format (Frame Rate for p and Field Rate for i)                       |
|-----------------------|------------|--|
| 0000                  | SMPTE 260M | 1035i 59.94 Hz and 60 Hz   |
| 0001                  | SMPTE 295M | 1080i 50 Hz  |
| 0010                  | SMPTE 274M | 1080i 59.94 Hz and 60 Hz<br>1080PsF 29.97 Hz and 30 Hz                     |
| 0011                  | SMPTE 274M | 1080i 50 Hz<br>1080PsF 25 Hz   |
| 0100                  | SMPTE 274M | 1080p 29.97 Hz and 30 Hz<br>1080p 59.94 Hz and 60 Hz (3G-SDI level B only) |
| 0101                  | SMPTE 274M | 1080p 25 Hz<br>1080p 50 Hz (3G-SDI level B only)                           |
| 0110                  | SMPTE 274M | 1080p 23.98 Hz and 24 Hz   |
| 0111                  | SMPTE 296M | 720p 59.94 Hz and 60 Hz  |
| 1000                  | SMPTE 274M | 1080PsF 23.98 Hz and 24 Hz   |
| 1001                  | SMPTE 296M | 720p 50 Hz   |
| 1010                  | SMPTE 296M | 720p 29.97 Hz and 30 Hz  |
| 1011                  | SMPTE 296M | 720p 25 Hz   |
| 1100                  | SMPTE 296M | 720p 23.98 Hz or 24 Hz   |
| 1101                  | SMPTE 274M | 1080p 59.94 Hz or 60 Hz (3G-SDI level A only)                              |
| 1110                  | SMPTE 274M | 1080p 50 Hz (3G-SDI level A only)  |
| 1111                  | Reserved   |  |

Table 4 describes the parameters (Verilog) or generics (VHDL) of the `s6_sdi_rx_light_20b` module.

Table 4: Parameters for the `s6_sdi_rx_light_20b` Module

| Parameter         | Default | Description   |
|-------------------|---------|---|
| NUM_SD_CE         | 2       | This parameter specifies the number of identical SD-SDI clock enable output signals provided on the <code>ce_sd</code> port. It specifies the width of the <code>ce_sd</code> port. All bits of the <code>ce_sd</code> port are identical, but separately generate copies. This parameter must never be set to less than 1.   |
| NUM_3G_DRDY       | 2       | This parameter specifies the number of identical 3G-SDI level B data ready outputs provided by the module on the <code>dout_rdy_3G</code> port. It specifies the width of the <code>dout_rdy_3G</code> port. All bits of the <code>dout_rdy_3G</code> port are identical, but separately generated copies. This parameter must never be set to less than 1.   |
| ERRCNT_WIDTH      | 4       | This parameter is used by the SDI mode detection function. It specifies the number of bits used in the SDI mode detection error counter. This counter must be wide enough to support counting up to <code>MAX_ERRS_LOCKED</code> and <code>MAX_ERRS_UNLOCKED</code> values.   |
| MAX_ERRS_LOCKED   | 15      | This parameter is used by the SDI mode detection function. It specifies the maximum number of consecutive lines with errors allowed while the receiver is locked to an SDI signal. When <code>MAX_ERRS_LOCKED</code> consecutive lines with errors are detected, the receiver moves to the unlocked state and begins searching for the new SDI mode. Reducing this value causes the SDI receiver to respond more quickly to an unlocked condition, reducing the time it takes to relock when the SDI input signal changes modes. However, reducing this value can also cause the receiver to be more prone to prematurely moving to an unlocked state during a burst of errors on the SDI signal. |
| MAX_ERRS_UNLOCKED | 2       | This parameter is used by the SDI mode detection function. When the receiver is actively searching for the SDI mode, this parameter specifies the maximum number of consecutive lines with errors allowed before the SDI mode search continues by moving to the next mode. Increasing this value gives the SDI receiver more time to lock to the SDI signal as it tries to lock in each SDI mode. However, testing has shown that a value of 2 provides adequate lock time while also minimizing the SDI mode detection search time.  |

## GTP RX Interface Module

Figure 2 shows a block diagram of the `gtp_interface_pll` module. This module abstracts the clock creation and buffering so that alternate clock creation and distribution schemes can be employed by the user, if desired. The 20-bit data is routed through this module to facilitate synchronization between clock domains, if it is required for the alternate clocking schemes.

The module creates the two synchronized user clocks required for interfacing to the GTP transceiver: `usrclk` and `usrclk2`. `Pipe_clk` is identical to `usrclk2`.

The input clock is the RX recovered clock from the GTP transceiver. Table 5 describes the inputs and outputs of this module. Figure 3 shows the `gtp_interface_pll` module in the context of a triple-rate SDI receiver. This module is also used for the GTP transmitter, but it requires a separate instance, and the usage and clock frequencies are different (see [GTP TX Interface Module, page 22](#)).

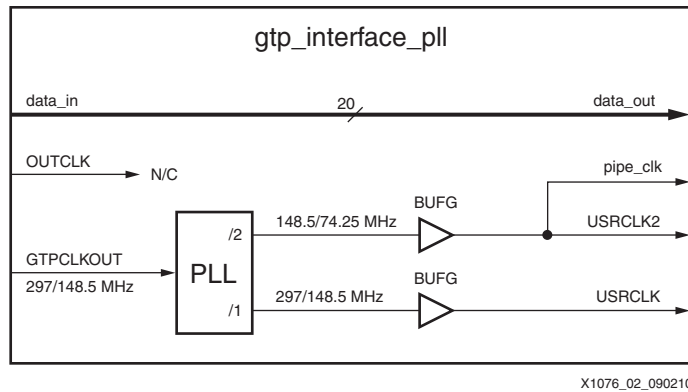

Figure 2: Block Diagram of the gtp\_interface\_pll Module

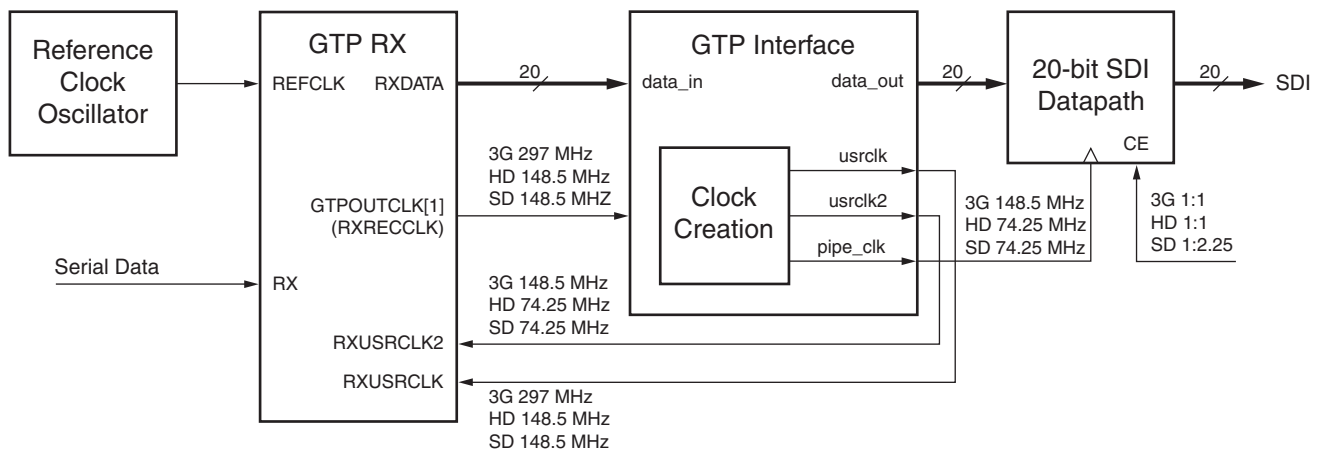

Figure 3: GTP Interface Module in RX Context

Table 5: I/O Ports of the gtp\_interface\_pll Module

| Port Name    | I/O | Width | Description  |
|--------------|-----|-------|--|
| outclk       | In  | 1     | Not used. Output clocks using dedicated clock routing come through gtpclkout.  |
| gtpoutclk    | In  | 1     | PLL input clock on dedicated clock routing. Nominally, 297 MHz for 3G-SDI and 148.5 MHz for HD-SDI and SD-SDI. This should be connected to the GTPOUTCLK[1] port of the GTP transceiver through a BUFIO2 buffer. |
| pll_reset_in | In  | 1     | Asynchronous PLL reset.<br>1 = Reset PLL.<br>0 = Do not reset PLL.   |
| data_in      | In  | 20    | 20-bit input data. This should be connected to the RXDATA port of the GTP transceiver.   |
| usrclk       | Out | 1     | Output user clock at one times the input clock rate. Nominally, 297 MHz for 3G-SDI, and 148.5 MHz for HD-SDI and SD-SDI. This is used to drive the USRCLK input of the GTP transceiver.                          |
| usrclk2      | Out | 1     | Output user clock at one-half times the input clock rate. Nominally, 148.5 MHz for 3G-SDI, and 74.25 MHz for HD-SDI and SD-SDI. This output drives the USRCLK2 input of the GTP transceiver.                     |
| pipe_clk     | Out | 1     | Pipeline clock for downstream pixel processing. This must be at the same frequency as usrclk2. In the reference design, it is the same clock.  |

Table 5: I/O Ports of the `gtp_interface_pll` Module (Cont'd)

| Port Name                   | I/O | Width | Description   |
|-----------------------------|-----|-------|---|
| <code>data_out</code>       | Out | 20    | 20-bit output data. This should be connected to the <code>data_in</code> port of the <code>S6_sdi_rx_light</code> module. |
| <code>pll_locked_out</code> | Out | 1     | Locked flag from the PLL.<br>1 = Locked.<br>0 = Unlocked.   |

## Operation of the Triple-Rate SDI Receiver in the Various SDI Modes

The triple-rate SDI receiver automatically determines the standard of the incoming SDI mode (SD-SDI, HD-SDI, 3G-SDI level A, or 3G-SDI level B). It does this by sequentially trying to lock to each SDI mode until it finds the correct SDI mode. When locked to the correct SDI mode, the receiver configures itself for correct operation in that mode. The recovered clock frequency and the number and data rate of the output data streams depend on the SDI mode.

### Triple-Rate SDI Clocking

The GTP receiver's CDR unit requires a reference clock, which can be either 74.25 MHz or 74.25/1.001 MHz. Some integer multiples of these frequencies are also supported. In particular, 148.5 MHz and 148.5/1.001 MHz are also commonly used. Only a single reference clock frequency is required to support SD-SDI at 270 Mb/s, HD-SDI at both bit rates, and 3G-SDI at both bit rates. The frequency of the reference clock should not change. Any change in the reference clock frequency requires resetting the GTP RX, including the RX PMA PLL.

The GTP receiver recovers a clock in 3G-SDI and HD-SDI modes, but not in SD-SDI mode. The recovered clock from the GTP transceiver is output on bit 1 of the `GTPOUTCLK` port. This port is connected to dedicated clock resources and is used in place of `RXRECCLK` to carry the recovered clock. The frequency of the recovered clock depends on the current SDI mode of the receiver. In HD-SDI mode, it is 148.5 MHz or 148.5/1.001 MHz. In 3G-SDI mode, it is 297 MHz or 297/1.001 MHz. In SD-SDI mode, the CDR unit is locked to the reference clock and `GTPOUTCLK[1]` is either 148.5 MHz or 148.5/1.001 MHz, depending on the frequency of the reference clock.

The `GTPOUTCLK[1]` output of the GTP receiver usually should be buffered by a `BUFIO2` buffer. The output of this clock buffer drives the `gtpoutclk1` input of the `gtp_interface_pll` module. The `gtp_interface_pll` module is shown in Figure 2. This module creates two synchronous clocks from the RX recovered clock by dividing the clock by 1 and 2 using a PLL. These clocks are buffered by global clock buffers. The `usrclk` output is at the recovered clock rate. The `usrclk2` output is at one-half the recovered clock rate. These two clocks are required by the GTP RX interface. They must be synchronous with each other and with the data going into the GTP interface. The `pipe_clk` is identical to `usrclk2` at one-half the rate of the recovered clock, and thus can be used to clock the 20-bit `s6_sdi_rx_light_20b` module and any other downstream logic. It can also be used to drive any additional downstream modules that need to be clocked by the recovered clock.

Internally, most of the logic in the `s6_sdi_rx_light_20b` module runs at the pipe clock frequency for HD-SDI and 3G-SDI (some portions run at half the pipe clock frequency in 3G-SDI level B mode). For SD-SDI, the internal data rate is 27 MHz. Clock enables are used in the `s6_sdi_rx_light_20b` module to run the various sections at the proper rates when the data rate is different from the clock frequency.

The `s6_sdi_rx_light_20b` module also supplies one or more copies of the SD-SDI clock enable on the `ce_sd` output port. These clock enables can be used, in conjunction with the recovered clock, to clock logic downstream from the `s6_sdi_rx_light_20b` module at the 27 MHz SD-SDI data rate. The `NUM_SD_CE` parameter/generic specifies the number of identical copies of `ce_sd` output by the module. `NUM_SD_CE` must never be set to less than 1.

The source of the `ce_sd` clock enable signal is the SD-SDI data recovery unit (DRU) located inside the `s6_sdi_rx_light_20b` module. Typically, the cadence of a `ce_sd` signal is 3/3/3/2 cycles of the clock. However, the cadence varies occasionally to make up for differences between the actual recovered data rate and the frequency of the reference clock. In all modes except SD-SDI, `ce_sd` is always High.

The `s6_sdi_rx_light_20b` module also outputs a `dout_rdy_3G` data ready signal. In 3G-SDI level B mode, `dout_rdy_3G` toggles at half the recovered clock frequency because the output data rate is 74.25 MHz and the clock frequency is 148.5 MHz. In all modes except 3G-SDI level B, `dout_rdy_3G` is always High. The `NUM_3G_DRDY` parameter/generic specifies the number of identical copies of the `dout_rdy_3G` signal output by the module. `NUM_3G_DRDY` should never be set to less than 1.

The `ce_sd` clock enable signals can be used as clock enables to those datapaths that only operate at the SD-SDI data rate, such as the optional SD-SDI EDH processor. The `ce_sd` signal is always High when not in SD-SDI mode. The `dout_rdy_3G` signal can be used as a clock enable to those datapaths that operate in HD-SDI and 3G-SDI modes, but not in SD-SDI mode. In SD-SDI mode, `dout_rdy_3G` is always High. If a datapath must operate correctly in all three SDI modes, it should use a clock enable that is the AND of a `ce_sd` signal and a `dout_rdy_3G` signal.

### SD-SDI Output Timing

When the triple-rate SDI receiver operates in SD-SDI mode, the frequency of `rxpipeclk` is 74.25 MHz or 74.25/1.001 MHz, depending on the reference clock frequency. The recovered SD-SDI data stream is output on the `ds1_a` port with the Y and C components interleaved at a 27 MHz data rate. The timing signals `trs`, `eav`, and `sav` are valid.

In SD-SDI mode, `pipe_clk` is not a recovered clock because the GTP receiver is locked to the reference clock and asynchronously samples the input bitstream. `pipe_clk` is, therefore, an exact multiple of the reference clock supplied to the GTP receiver.

A data recovery unit (DRU) in the `s6_sdi_rx_light_20b` module recovers the actual data stream from the oversampled data. The DRU provides a data ready signal that is asserted when it has a 10-bit data word ready. The `s6_sdi_rx_light_20b` module outputs this data ready signal on the `ce_sd` output. On average, this output is asserted once every 2.75 clock cycles by using a 3/3/3/2 clock cycle cadence. The output cadence is occasionally altered when the DRU needs to catch up to the actual data rate. This occurs because the GTP transceiver reference clock is a local clock and is asynchronous to the actual timing of the incoming SD-SDI bitstream. High amounts of jitter on the SD-SDI can also cause the cadence to vary.

Figure 4 shows the timing of the SD video and timing signals output by the `s6_sdi_rx_light_20b` module. The outputs only change on the rising edge of `clk` when `ce_sd` is High. The timing of the EAV sequence is shown. The `sav` output signal has the same timing as the `eav` signal except that it is asserted during SAV sequences.

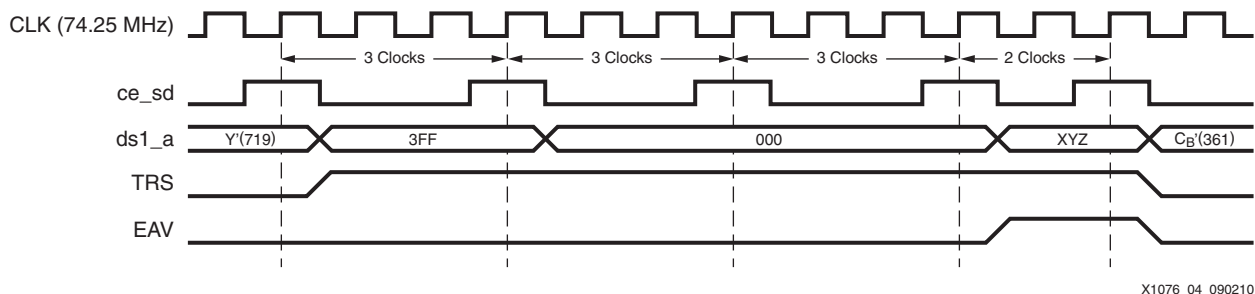

X1076\_04\_090210

Figure 4: SD-SDI RX Timing Diagram

### HD-SDI Output Timing

When the triple-rate SDI receiver operates in HD-SDI mode, pipe\_clk is based on a true recovered clock and runs at 74.25 MHz or 74.25/1.001 MHz, depending on the HD-SDI bit rate. The Y and C data streams of the HD-SDI signal are output on the ds1\_a and ds2\_a ports, respectively, along with the timing signals trs, eav, and sav. The line number is output on the In\_a port. In HD-SDI mode, the line number changes during the CRC0 word. Figure 5 shows the timing of the HD-SDI outputs.

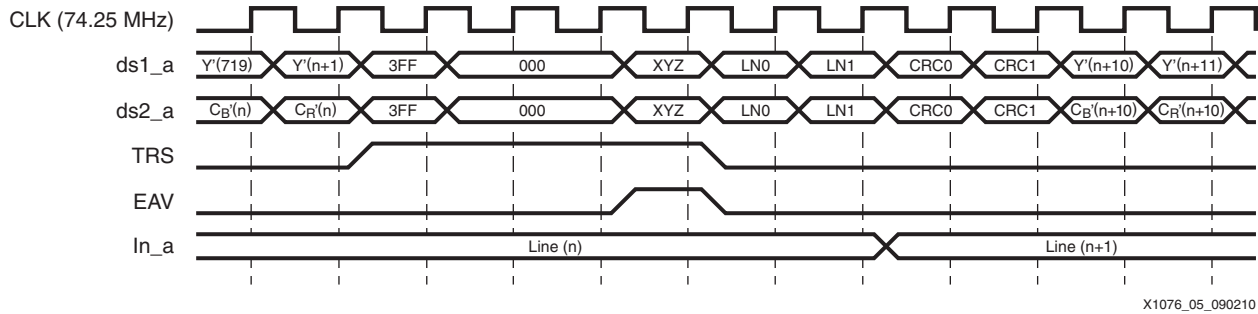

Figure 5: HD-SDI RX Timing Diagram

### 3G-SDI Level A Output Timing

When the triple-rate SDI receiver operates in 3G-SDI level A mode, the frequency of pipe\_clk is 148.5 MHz or 148.5/1.001 MHz, depending on the 3G-SDI bit rate.

Figure 6 shows the output timing of the s6\_sdi\_rx\_light\_20b module when receiving a 1080p 50, 59.94, or 60 Hz signal in 3G-SDI level A mode. These video formats do not require further unpacking of the data streams, because ds1\_a carries the luma component and ds2\_a carries the multiplexed chroma components.

Other video formats, such as 4:4:4 10-bit or 12-bit, have identical timing to that shown in Figure 6, but the video samples are packed as specified by the SMPTE 425 so that it takes two consecutive words on each data stream to carry a single video sample. The s6\_sdi\_rx\_light\_20b module does not unpack these other video formats, but outputs the two data streams exactly as described in the 3G-SDI level A data stream mapping sections of SMPTE 425.

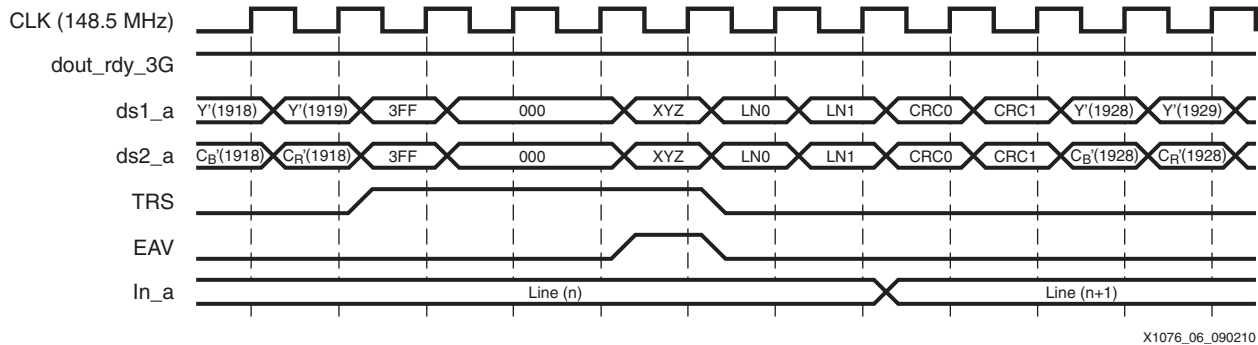

Figure 6: 3G-SDI Level A RX Timing (1080p 50 Hz or 60 Hz)

### 3G-SDI Level B Output Timing

When the triple-rate SDI receiver operates in 3G-SDI level B mode, the frequency of pipe\_clk is 148.5 MHz or 148.5/1.001 MHz, depending on the 3G-SDI bit rate. However, in this mode, there are four 10-bit data streams output by the s6\_sdi\_rx\_light\_20b module. The data rate of these data streams is half the frequency of pipe\_clk, therefore, the dout\_rdy\_3G signal is asserted every other clock cycle and acts as a clock enable.

Figure 7 shows the output timing of the `s6_sdi_rx_light_20b` module when receiving a 3G-SDI level B signal.

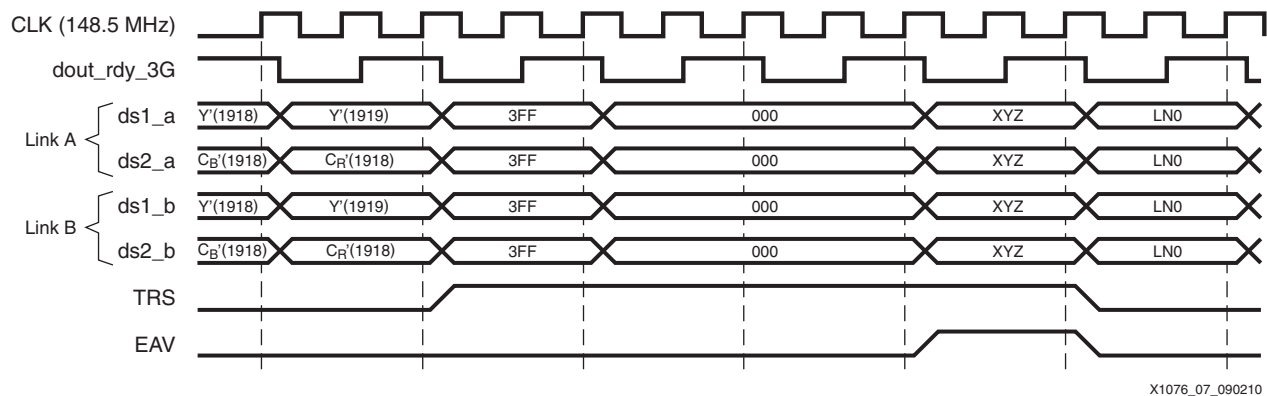

Figure 7: 3G-SDI Level B RX Timing

Both line number output ports are active. When the level B signal is transporting SMPTE 372 dual-link data streams, the values on both `ln_a` and `ln_b` are identical and indicate the interface line number, not the picture line number. When the level B signal is transporting two independent HD-SDI signals, the two line number values are not necessarily the same, depending on whether the two HD-SDI signals are frame locked or not. The `ln_a` and `ln_b` ports, not shown in Figure 7, change at the same relative position as they do for 3G-SDI level A and HD-SDI, as the CRC0 word is output on the data streams.

When the 3G-SDI level B signal carries SMPTE 372 dual-link data streams, the link A data streams are output on `ds1_a` and `ds2_a` and the link B data streams are output on `ds1_b` and `ds2_b`. These four links carry video mapped as required by SMPTE 372. The `s6_sdi_rx_light_20b` module does not unpack the data streams into video, but outputs them as SMPTE 372 data streams.

When the 3G-SDI level B signal carries two independent HD-SDI streams, the first HD-SDI stream is output with the luma component on `ds1_a` and the multiplexed chroma components on `ds2_a`. The second HD-SDI stream is output with the luma component on `ds1_b` and the multiplexed chroma component on `ds2_b`. These two HD-SDI streams are horizontally synchronized so that their EAVs and SAVs always line up exactly, therefore there is only a single set of eav, sav, and trs timing signals.

## Other Triple-Rate SDI RX Design Considerations

To incorporate the triple-rate receiver into a complete system, the designer should take into account some additional considerations. This section describes those considerations.

### HD-SDI and 3G-SDI Bit Rate Detection

The `s6gtp_sdi_control` module contains a bit rate detector. The `rx_rate` output of the `s6gtp_sdi_control` module is 0 when the incoming bit rate is 1.485 Gb/s or 2.97 Gb/s. It is 1 when the incoming bit rate is 1.485/1.001 Gb/s or 2.97/1.001 Gb/s. The bit rate detector depends on a known constant frequency clock supplied to the `s6gtp_sdi_control` module on its `dclk` port. Refer to [SDI GTP Transceiver Control Module, page 32](#) for a detailed description of this module.

### Dual-Link HD-SDI

To implement a dual-link HD-SDI receiver, two triple-rate SDI receivers are paired together with one receiving link A and the other receiving link B. Typically, the received data streams for the two links are skewed, so the skew must be removed. Next, the data streams can be unpacked into video streams, if desired.

Deskewing the data streams involves watching the EAV or SAV signals from each link and delaying the data streams of the link whose EAV becomes asserted first by an appropriate amount to match the timing of the other link. The Spartan-6 FPGA SRL elements make perfect delay devices for implementing this deskew function.

### Processing Embedded Audio and Other Ancillary Data

The data streams that are output from the triple-rate SDI receiver always have all ancillary data intact, including embedded audio packets. Modules designed to process ancillary data can be connected to the data streams, clock enables, and other timing signals output by the triple-rate SDI receiver.

### SMPTE 352 Video Payload ID Packets

The triple-rate SDI receiver module captures SMPTE 352 packets present in the data streams for all SDI modes. For SD-SDI and HD-SDI, the four data bytes of the SMPTE 352 packet are output on the a\_vpid port. The a\_vpid\_valid port indicates when valid SMPTE 352 packets have been captured. This output has some hysteresis so that SMPTE 352 packets can be missing from a few fields or frames before the valid signal is negated. During the time that the valid output is asserted and new SMPTE 352 packets are not found, the data from the last valid SMPTE 352 packet received is output on the a\_vpid port.

The 3G-SDI standard requires SMPTE 352 packets in both data streams. The triple-rate SDI receiver captures the SMPTE 352 packets from both streams, outputting the data from the packet in data stream 1 on a\_vpid and the data from the packet in data stream 2 on b\_vpid. The module also provides individual a\_vpid\_valid and b\_vpid\_valid outputs.

### SD-SDI EDH Error Detection

The triple-rate SDI receiver detects CRC errors in HD-SDI and 3G-SDI modes, but it does not contain an EDH error checker. However, either of the two EDH processors described in Chapters 6 and 7 of *Audio/Video Connectivity Solutions for Virtex-II Pro and Virtex-4 FPGAs* [Ref 1] can be connected downstream from the s6\_sdi\_rx\_light\_20b module to check the SD-SDI data stream for EDH errors.

### SD-SDI Data Recovery Unit

The triple-rate SDI receiver uses a DRU to recover the SD-SDI data. This DRU is based on the digital PLL data recovery design described in *Dynamically Programmable DRU for High-Speed Serial I/O* [Ref 2], but has been optimized for SD-SDI and ported to the Spartan-6 FPGA. This SD-SDI DRU has been optimized for use with 5.5X oversampled 270 Mb/s data. By optimizing the DRU specifically for SD-SDI, it is much smaller than the general-purpose implementation of the DRU. The SD-SDI DRU has also been optimized so that the reference clock used for SD-SDI reception can be either 74.25 MHz or 74.25/1.001 MHz.

### Electrical Interface

The GTP receiver must be connected to the SDI connector through an SDI cable equalizer. The equalizer serves two purposes. It equalizes the SDI signal to compensate for signal distortion and attenuation, and it converts the single-ended 75Ω SDI signal to a differential signal compatible with the GTP receiver input. Most, if not all, SDI cable equalizers currently available do not have a common mode output directly compatible with the Spartan-6 FPGA GTP transceiver inputs. Therefore AC coupling is required to shift the common mode voltage of the signal as it enters the GTP receiver. The GTP receiver has built-in AC coupling, but these internal capacitors are not adequate to support the long run lengths of the SDI signals. The internal AC coupling must be bypassed, and external AC coupling capacitors must be used. The value of these external capacitors is usually about 4.7 μF. Nothing else needs to be done to set the common mode voltage because the GTP receiver provides a correct termination voltage to set the common mode voltage on its inputs.

## Triple-Rate SDI Transmitter Reference Design

The Spartan-6 FPGA SDI transmitter provides the basic operations necessary to support SD-SDI, HD-SDI, dual-link HD-SDI, and 3G-SDI transmission. The transmitter does not perform video mapping for 3G-SDI or dual-link HD-SDI. Video formats that require mapping must be mapped into SDI data streams prior to the triple-rate SDI TX module. These video formats include those in [Table 1](#) marked “external” in the “SDI Stream Mapping column: 3G-SDI level A formats except 1080p 50 Hz, 59.94 Hz, and 60 Hz, all 3G-SDI level B formats, and all dual-link HD-SDI formats.

The Spartan-6 FPGA GTP transceiver triple-rate SDI transmitter has these features:

- A 20-bit GTP interface, supported on -3 and faster Spartan-6 devices.
- Only two reference clock frequencies are required to support all SDI modes:
  - 148.5 MHz for SD-SDI at 270 Mb/s, HD-SDI at 1.485 Gb/s, and 3G-SDI at 2.97 Gb/s.
  - 148.5/1.001 MHz for HD-SDI at 1.485/1.001 Gb/s and 3G-SDI at 2.97/1.001 Gb/s.
- Direct support for 3G-SDI level A transmission of 1080p 50 Hz, 59.94 Hz, and 60 Hz video.
- Transmission of preformatted dual-link HD-SDI streams via either dual-link HD-SDI or 3G-SDI level B formats.
- With the addition of a 3G-SDI level A mapping module, supports all 3G-SDI level A compatible video formats.
- Direct support for transmission of two independent HD-SDI streams via 3G-SDI level B format.
- EDH packets generated and updated for SD-SDI mode.
- CRC values can be generated and inserted for HD-SDI and 3G-SDI modes.
- Line number words inserted for HD-SDI and 3G-SDI modes.
- SMPTE 352M video payload ID packets can be generated and inserted in all SDI modes.

A block diagram of the Spartan-6 FPGA GTP Transceiver triple-rate SDI transmitter is shown in [Figure 8](#).

The transmitter datapath consists of three modules: `triple_sdi_vpid_insert`, `triple_sdi_tx_output_20b`, and `gtp_interface_pll`. These three modules, combined with the GTP transceiver and the `s6gtp_sdi_control` module, form the triple-rate SDI transmitter design. One `s6gtp_sdi_control` module is required per GTP transceiver (RX/TX pair). If both the RX and the TX in a GTP transceiver are used for SDI, only one `s6gtp_sdi_control` module is required for that transceiver. [Figure 8](#) only shows the transmitter connections of the GTP transceiver wrapper and the `s6gtp_sdi_control` module.

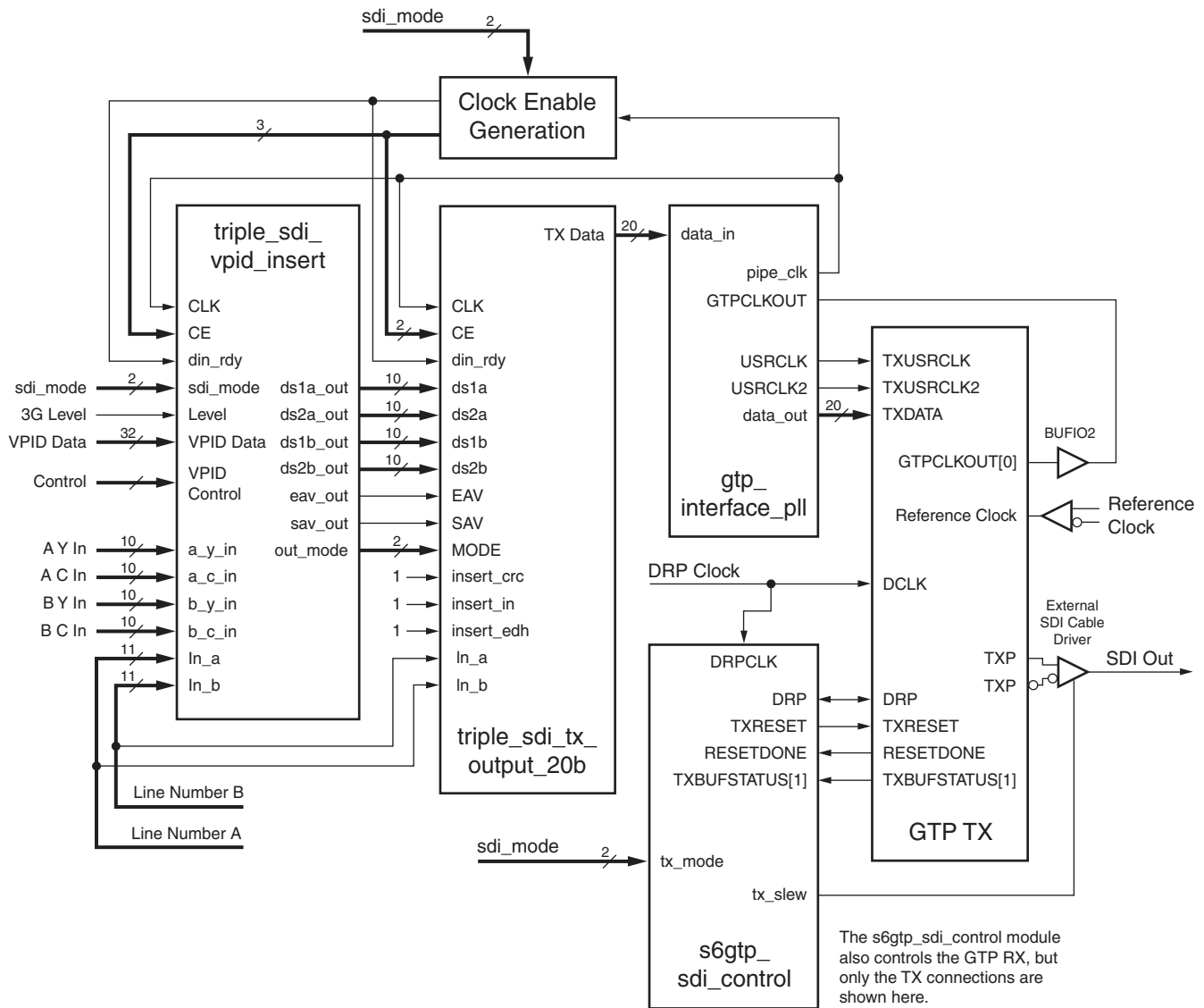

X1076\_08\_120210

Figure 8: Spartan-6 FPGA GTP Transceiver Triple-Rate SDI Transmitter Block Diagram

### Triple-Rate SDI Transmitter Datapath Modules

The triple-rate SDI transmitter datapath consists of two datapath modules, the `triple_sdi_vpid_insert` module, which inserts SMPTE 352 video payload ID packets into the data streams, and the `triple_sdi_tx_output_20b` module, which creates a final output data stream suitable for input to the TXDATA port of the GTP transmitter.

### Triple-Rate SDI VPID Insert Module

Table 6 describes the ports of the `triple_sdi_vpid_insert` module. This module is the front-end of the triple-rate SDI transmitter. Its main function is to insert SMPTE 352 video payload ID packets into the data streams, but it also provides some additional functions required by the `triple_sdi_tx_output_20b` module, such as detecting and identifying EAV and SAV sequences and generating the `out_mode` signal that connects to the mode port of the output module. Even if SMPTE 352 packets do not need to be inserted in a particular application (these packets are required for 3G-SDI and dual-link HD-SDI modes), the `triple_sdi_vpid_insert` module is still required to perform these additional functions. If the `triple_sdi_vpid_insert` module's enable input port is wired Low, the actual

SMPTE 352 packet generation and insertion logic is optimized out of the design, and only the additional required functions of the module are retained by the synthesizer.

Table 6: I/O Ports of the `triple_sdi_vpid_insert` Module

| Port Name | I/O | Width | Description  |
|-----------|-----|-------|--|
| clk       | In  | 1     | This clock input must be driven by the <code>pipe_clk</code> . It must have a frequency of 74.25 MHz or 74.25/1.001 MHz for HD-SDI, 148.5 MHz or 148.5/1.001 MHz for 3G-SDI, and 148.5 MHz for SD-SDI modes.   |
| ce        | In  | 1     | The clock enable must be asserted at a 27 MHz rate for SD-SDI mode (with a mandatory 5/6/5/6 clock cycle cadence). For all other SDI modes, the clock enable is always High.   |
| din_rdy   | In  | 1     | For SD-SDI, HD-SDI, and level A 3G-SDI modes, this input must be kept High at all times. For level B 3G-SDI mode, this input must be asserted every other clock cycle.   |
| rst       | In  | 1     | This asynchronous reset input resets the module when High. The falling edge of this reset signal must meet the reset recovery time of all flip-flops relative to the next rising edge of <code>clk</code> .  |
| sdi_mode  | In  | 1     | This input port is used to select the transmitter SDI mode: <ul style="list-style-type: none"> <li>00 = HD-SDI (including dual-link HD-SDI)</li> <li>01 = SD-SDI</li> <li>10 = 3G-SDI</li> <li>11 = Invalid</li> </ul>   |
| level     | In  | 1     | In 3G-SDI mode, this input determines whether the module inserts SMPTE 352 packets for level A (level = Low) or for level B (level = High). Because these two 3G-SDI levels have different requirements for placement of SMPTE 352 packets, this input must be properly controlled, otherwise the data streams generated by the module are not legal.  |
| enable    | In  | 1     | When this input is High, SMPTE 352 packets are inserted into the data streams, otherwise the packets are not inserted. SMPTE 352 packets are mandatory in 3G-SDI and dual-link HD-SDI modes.   |
| overwrite | In  | 1     | If this input is High, SMPTE 352 packets already present in the data streams are overwritten. If this input is Low, existing SMPTE 352 packets are not overwritten. When transporting SMPTE 372 dual-link data streams on a 3G-SDI level B interface, existing SMPTE 352 packets in the data streams must be updated to indicate that the interface is 3G-SDI rather than HD-SDI mode. This module updates these packets only when <code>overwrite</code> is High. |
| byte1     | In  | 8     | This value is inserted as the first user data word of the SMPTE 352 packet. It must be valid during the entire HANC interval.  |
| byte2     | In  | 8     | This value is inserted as the second user data word of the SMPTE 352 packet. It must be valid during the entire HANC interval.   |
| byte3     | In  | 8     | This value is inserted as the third user data word of the SMPTE 352 packet. It must be valid during the entire HANC interval.  |
| byte4a    | In  | 8     | This value is inserted as the fourth user data word of the SMPTE 352 packet. This word is used for the SMPTE 352 packets inserted into SD-SDI, HD-SDI, and 3G-SDI level A data streams. For 3G-SDI level B and dual-link HD-SDI modes, this value is used for the SMPTE 352 packet inserted into Y channel of link A only. This input must be valid during the entire HANC interval.   |
| byte4b    | In  | 8     | This value is inserted as the fourth user data word of SMPTE 352 packets inserted in the Y channel of link B for 3G-SDI level B and dual-link HD-SDI modes only. This input value is not used for SD-SDI, HD-SDI, or 3G-SDI level A modes. This input must be valid during the entire HANC interval.   |

Table 6: I/O Ports of the triple\_sdi\_vpid\_insert Module (Cont'd)

| Port Name  | I/O | Width | Description  |
|------------|-----|-------|--|
| In_a       | In  | 11    | <p>The current line number must be provided to the module through this port if SMPTE 352 packet insertion is enabled. If SMPTE 352 packet insertion is disabled in a particular SDI mode, SD-SDI for example, valid line numbers do not need to be supplied on this port in that SDI mode.</p> <p>SD-SDI only uses 10-bit line numbers, so bit 10 of the port must be 0 in SD-SDI mode.</p> <p>The line number must be valid at least one clock cycle before the start of the HANC space (by the XYZ word of the EAV) and must remain valid during the entire HANC interval.</p> <p>This input is the only line number input used for SD-SDI, HD-SDI, and 3G-SDI level A modes. For 3G-SDI level B mode, a second line number input port, In_b, is also provided. The line numbers input on the In_a port are used only to identify the line for the purposes of inserting SMPTE 352 packets.</p> <p>For video formats where the picture line number is different from the transport line number, the value supplied on this port must be the transport line number.</p> |
| In_b       | In  | 11    | <p>This second line number input port is used only for 3G-SDI level B format. This additional line number port allows the two separate HD-SDI signals to be vertically unsynchronized when level B carries two independent HD-SDI signals. This input port has the same timing and other requirements described for In_a.</p>  |
| line_f1    | In  | 11    | <p>The SMPTE 352 packet is inserted in the HANC space of the line number specified by this input port. For interlaced video, this input port specifies a line number in field 1. For progressive video, this specifies the only line in the frame where the packet is inserted. The input value must be valid during the entire HANC interval.</p>   |
| line_f2    | In  | 11    | <p>For interlaced video, a SMPTE 352 packet is inserted on the line number in field 2 indicated by this value. For progressive video, this input port must be disabled by holding the line_f2_en port Low. The input value must be valid during the entire HANC interval.</p>  |
| line_f2_en | In  | 1     | <p>This input controls whether or not SMPTE 352 packets are inserted on the line indicated by line_f2. For interlaced video, this input must be High. For progressive video, this input must be Low. For progressive video transported on an interlaced transport, such as 1080p 60 Hz transported by either 3G-SDI level B or dual-link HD-SDI, SMPTE 352 packets must be inserted into both fields of the interlaced transport, so this input must be High. This input must be valid during the entire HANC interval.</p>  |
| a_y_in     | In  | 10    | <p>This is the data stream A Y input. The data on this port depends on the SDI mode:</p> <ul style="list-style-type: none"> <li>SD-SDI: The multiplexed Y/C data stream enters the module on this port.</li> <li>HD-SDI: The Y data stream enters the module on this port.</li> <li>3G-SDI level A: Data stream 1, as defined by SMPTE 425, enters the module on this port.</li> <li>Dual-link HD-SDI or 3G-SDI level B transporting dual-link HD-SDI: The Y data stream of link A enters the module on this port.</li> <li>3G-SDI level B transporting dual HD-SDI signals: The Y data stream of HD-SDI signal 1 enters the module on this port.</li> </ul>   |
| a_c_in     | In  | 10    | <p>This is the data stream A C input. The data on this port depends on the SDI mode:</p> <ul style="list-style-type: none"> <li>HD-SDI and 3G-SDI level A: The C data stream enters the module on this port.</li> <li>Dual-link HD-SDI or 3G-SDI level B transporting dual-link HD-SDI: The C data stream of link A enters the module on this port.</li> <li>3G-SDI level B transporting dual HD-SDI signals: The C data stream of HD-SDI signal 1 enters the module on this port.</li> </ul>  |
| b_y_in     | In  | 10    | <p>This is the data stream B Y input: The data stream on this port depends on the SDI mode:</p> <ul style="list-style-type: none"> <li>Dual-link HD-SDI or 3G-SDI level B carrying dual-link HD-SDI: The Y data stream of link B enters the module on this port.</li> <li>3G-SDI level B carrying dual HD-SDI signals: The Y data stream of HD-SDI signal 2 enters the module on this port.</li> <li>For other SDI modes, this input port is unused.</li> </ul>  |

Table 6: I/O Ports of the `triple_sdi_vpid_insert` Module (Cont'd)

| Port Name | I/O | Width | Description  |
|-----------|-----|-------|--|
| b_c_in    | In  | 10    | This is the data stream B C input: The data stream on this port depends on the SDI mode: <ul style="list-style-type: none"> <li>Dual-link HD-SDI or 3G-SDI level B carrying dual-link HD-SDI: the C data stream of link B enters the module on this port.</li> <li>3G-SDI level B carrying dual HD-SDI signals: The C data stream of HD-SDI signal 2 enters the module on this port.</li> <li>For other SDI modes, this input port is unused.</li> </ul> |
| ds1a_out  | Out | 10    | Data stream 1 of link A is output on this port.  |
| ds2a_out  | Out | 10    | Data stream 2 of link A is output on this port.  |
| ds1b_out  | Out | 10    | Data stream 1 of link B is output on this port. This port is only used in 3G-SDI level B and dual-link HD-SDI modes.   |
| ds2b_out  | Out | 10    | Data stream 2 of link B is output on this port. This port is only used in 3G-SDI level B and dual-link HD-SDI modes.   |
| eav_out   | Out | 1     | This output is High when the XYZ word of an EAV is output on the data stream outputs.  |
| sav_out   | Out | 1     | This output is High when the XYZ word of an SAV is output on the data stream outputs.  |
| out_mode  | Out | 2     | This output port must be connected to the mode input port of the <code>triple_sdi_tx_output_20b</code> module.   |

### Triple-Rate SDI Output Module

Table 7 describes the ports of the `triple_sdi_tx_output_20b` module. This module is the back end of the triple-rate SDI transmitter datapath. It takes in one, two, or four data streams, depending on the SDI mode, from the `triple_sdi_vpid_insert` module, optionally generates and inserts EDH packets (in SD-SDI mode) or CRC and LN words (in HD-SDI and 3G-SDI modes), and then scrambles the data and outputs a single 20-bit data stream to the `gtp_interface_tx` module.

Table 7: I/O Ports of the `triple_sdi_tx_output_20b` Module

| Port Name | I/O | Width | Description  |
|-----------|-----|-------|--|
| clk       | In  | 1     | This clock input must be driven by the <code>pipe_clk</code> . It must have a frequency of 74.25 MHz or 74.25/1.001 MHz for HD-SDI, 148.5 MHz or 148.5/1.001 MHz for 3G-SDI, and 148.5 MHz for SD-SDI modes.   |
| ce        | In  | 2     | The clock enable must be asserted at a 27 MHz rate for SD-SDI with a mandatory 5/6/5/6 clock cycle cadence. For other SDI modes, this clock enable must always be High. The module requires two identical copies of this clock enable signal on its <code>ce</code> port. For most applications, both bits of the <code>ce</code> port can be driven with the same clock enable signal. <code>ce[0]</code> controls everything except the EDH processor, and <code>ce[1]</code> controls just the EDH processor. If EDH packet insertion or updating is not required, <code>ce[1]</code> can be tied Low and the EDH processor is optimized out of the design by the synthesis tool. |
| din_rdy   | In  | 1     | For SD-SDI, HD-SDI, and 3G-SDI level A formats, this input must be kept High at all times. For 3G-SDI level B format, this input must be asserted every other clock cycle.   |
| rst       | In  | 1     | This asynchronous reset input resets the module when High. The falling edge of this reset signal must meet the reset recovery time of all flip-flops relative to the next rising edge of <code>clk</code> .  |
| mode      | In  | 2     | This input port selects the mode of operation of this module. Normally, the <code>out_mode</code> port of the <code>triple_sdi_vpid_insert</code> module is connected to this input port. This port is encoded as follows: <ul style="list-style-type: none"> <li>00 = HD-SDI, 3G-SDI level A, and dual-link HD-SDI</li> <li>01 = SD-SDI</li> <li>10 = 3G-SDI level B</li> <li>11 = Invalid</li> </ul>   |

Table 7: I/O Ports of the `triple_sdi_tx_output_20b` Module (Cont'd)

| Port Name    | I/O | Width | Description   |
|--------------|-----|-------|---|
| ds1a         | In  | 10    | This input is driven by the <code>ds1a_out</code> port of the <code>triple_sdi_vpid_insert</code> module. The data on this input port depends on the SDI mode: <ul style="list-style-type: none"> <li>SD-SDI: Multiplexed Y/C data stream for SD-SDI</li> <li>HD-SDI: Dual-link HD-SDI and 3G-SDI level A: Y data stream</li> <li>3G-SDI level B: Y data stream of link A or Y data stream of HD-SDI signal 1</li> </ul>  |
| ds2a         | In  | 10    | This input is driven by the <code>ds2a_out</code> port of the <code>triple_sdi_vpid_insert</code> module. The data on this input port depends on the SDI mode: <ul style="list-style-type: none"> <li>SD-SDI: Not used</li> <li>HD-SDI: Dual-link HD-SDI and 3G-SDI level A: C data stream</li> <li>3G-SDI level B: C data stream of link A or C data stream of HD-SDI signal 1</li> </ul>  |
| ds1b         | In  | 10    | This input is driven by the <code>ds1b_out</code> port of the <code>triple_sdi_vpid_insert</code> module. It carries the Y data stream of link B for 3G-SDI level B or of HD-SDI signal 2. It is unused in all other modes.   |
| ds2b         | In  | 10    | This input is driven by the <code>ds2b_out</code> port of the <code>triple_sdi_vpid_insert</code> module. It carries the C data stream of link B for 3G-SDI level B or of HD-SDI signal 2. It is unused in all other modes.   |
| insert_crc   | In  | 1     | When this input is High, CRC values are calculated and inserted into all data streams when running in HD-SDI and 3G-SDI modes. This input is ignored in SD-SDI mode.  |
| insert_ln    | In  | 1     | When this input is High, LN (line number) words are inserted after the EAVs in all data streams when running in HD-SDI and 3G-SDI modes. This input is ignored in SD-SDI mode.  |
| insert_edh   | In  | 1     | When this input is High, EDH packets are generated and inserted into the SD-SDI data stream. This input is ignored when running in HD-SDI and 3G-SDI modes.   |
| In_a         | In  | 1     | This is the primary line number input port. A value is required on this port for HD-SDI and 3G-SDI modes when the <code>insert_ln</code> port is High.<br>The line number input must be stable by the XYZ word of the EAV, and must remain stable for at least two sample times.<br>For HD-SDI, dual-link HD-SDI, and level A 3G-SDI modes, this is the only line number input port used, and the value on this port is inserted into the <code>ds1a</code> and <code>ds2a</code> streams. For level B 3G-SDI mode, a second line number port, <code>In_b</code> , is also used. The <code>In_a</code> input port is not used for SD-SDI mode.<br>For those video formats where the transport line number is not the same as the picture line number, the value on this port must be the transport line number. |
| In_b         | In  | 11    | When transmitting in level B 3G-SDI format, and when the <code>insert_ln</code> signal is High, the line number on this port is inserted into the <code>ds1b</code> and <code>ds2b</code> data streams. This allows the two independent HD-SDI signals carried by level B to be vertically unsynchronized. This input port is not used for SD-SDI, HD-SDI, or 3G-SDI level A formats. This input has the same timing and other requirements as described for <code>In_a</code> .  |
| eav          | In  | 1     | This input must be High when the XYZ word of each EAV enters the module on the data stream inputs. This input is not required for SD-SDI mode. This port is typically driven by the <code>eav_out</code> port of the <code>triple_sdi_vpid_insert</code> module.  |
| sav          | In  | 1     | This input must be High when the XYZ word of each SAV enters the module on the data stream inputs. This input is not required for SD-SDI mode. This port is typically driven by the <code>sav_out</code> port of the <code>triple_sdi_vpid_insert</code> module.  |
| txdata       | Out | 20    | The scrambled SDI data stream is output on this port. The data should be directly connected to the <code>pipe_data</code> port of the <code>gtp_interface_pll</code> module. For SD-SDI mode, this data is 5.5X-oversampled data running at 74.25 MHz. For HD-SDI mode, it runs at the native data rate of 74.25 MHz. For 3G-SDI mode, the native data rate is 148.5 MHz.   |
| ce_align_err | Out | 1     | The SD-SDI bit replication logic requires that the <code>ce</code> input signal has an exact 5/6/5/6 clock cycle cadence. If the <code>ce</code> signal varies from this cadence, the bit replication logic underflows or overflows, and the <code>ce_align_err</code> output is asserted High until the cadence returns to normal.   |

## GTP TX Interface Module

A block diagram of the `gtp_interface_pll` module is shown in Figure 9. This module abstracts the clock creation and buffering so that alternate clock creation and distribution schemes can be employed by the user, if desired. The 20-bit data is routed through this module to facilitate synchronization between clock domains, if required for these alternate clocking schemes.

The module creates the two synchronized user clocks required for interfacing to the GTP transceiver: `usrclk`, and `usrclk2`. The `pipe_clk` signal is identical to `usrclk2`. The input clock is the TX output clock from the GTP transceiver, which is based on the reference clock.

Table 8 describes the inputs and outputs of the `gtp_interface_pll` module. Figure 10 shows the `gtp_interface_pll` module in the context of a triple-rate SDI transmitter. This module is also used for the GTP receiver, but it requires a separate instance, and the usage and some clock frequencies are different (see [GTP RX Interface Module, page 9](#)).

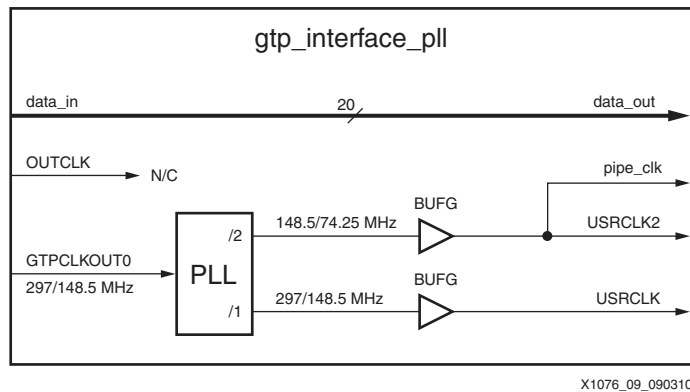

Figure 9: Block Diagram of the `gtp_interface_pll` Module

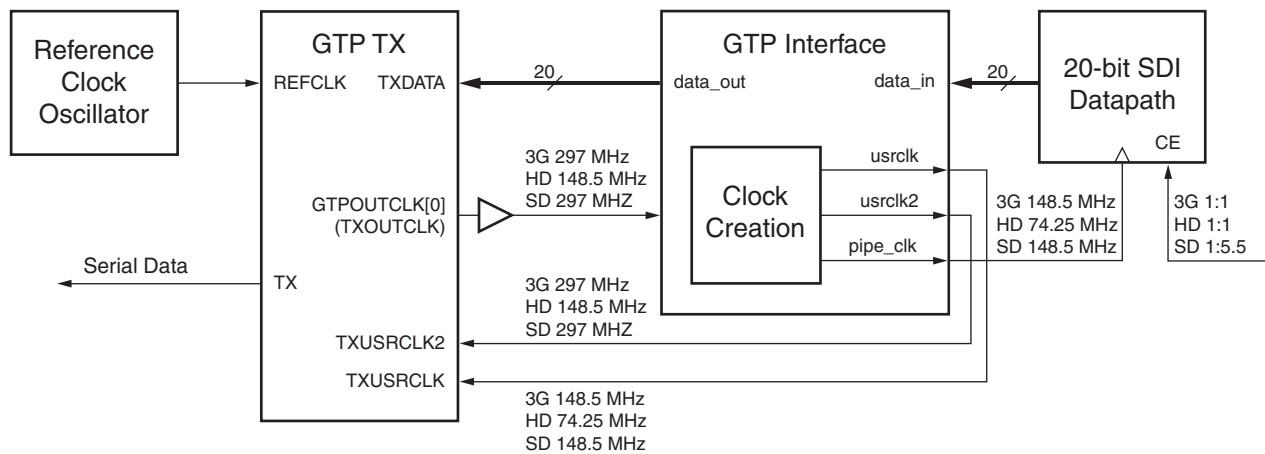

Figure 10: GTP Interface Module in TX Context

Table 8: I/O Ports of the `gtp_interface_pll` Module

| Port Name | I/O | Width | Description  |
|-----------|-----|-------|--|
| outclk    | In  | 1     | Not used. Output clocks using dedicated clock routing come through <code>gtpclkout</code> .  |
| gtpoutclk | In  | 1     | PLL input clock on dedicated clock routing. Nominally, 297 MHz for 3G-SDI and SD-SDI, and 148.5 MHz for HD-SDI. This should be connected to the <code>GTPOUTCLK[1]</code> port of the GTP transceiver through a BUFIO2 buffer. |

Table 8: I/O Ports of the gtp\_interface\_pll Module (Cont'd)

| Port Name      | I/O | Width | Description   |
|----------------|-----|-------|---|
| pll_reset_in   | In  | 1     | Asynchronous PLL reset.<br>1 = Reset PLL<br>0 = Do not reset PLL  |
| data_in        | In  | 20    | 20-bit input data. This should be connected to the txdata port of the triple_sdi_tx_output_20b module.  |
| usrclk         | Out | 1     | Output user clock at 1X the input clock rate. Nominally, 297 MHz for 3G-SDI and SD-SDI, and 148.5 MHz for HD-SDI. This is used to drive the USRCLK input of the GTP transceiver.      |
| usrclk2        | Out | 1     | Output user clock at 1/2x the input clock rate. Nominally, 148.5 MHz for 3G-SDI and SD-SDI, and 74.25 MHz for HD-SDI. This is used to drive the USRCLK2 input of the GTP transceiver. |
| pipe_clk       | Out | 1     | Pipeline clock for downstream pixel processing. This must be at the same frequency as usrclk2. In the reference design it is the same clock.  |
| data_out       | Out | 20    | 20-bit output data. This should be connected to the TXDATA port of the GTP transceiver.   |
| pll_locked_out | Out | 1     | Locked flag from the PLL.<br>1 = Locked<br>0 = Not locked   |

## Operation of the Triple-Rate SDI Transmitter in the Various SDI Modes

The SDI mode (SD-SDI, HD-SDI, 3G-SDI level A or 3G-SDI level B) of the triple-rate SDI transmitter is determined by the mode and level inputs of the transmitter datapath modules. The clock frequency requirements and the number of data streams expected by the triple-rate SDI transmitter datapath depend on the SDI mode.

### SD-SDI Transmitter Operation

When operating in SD-SDI mode, the pipe\_clk from gtp\_interface\_tx module has a frequency of 148.5 MHz. The interleaved Y/C data stream is connected to the a\_y\_in port of the triple\_sdi\_vpid\_insert module. The clock enable inputs of both modules (triple\_sdi\_vpid\_insert and triple\_sdi\_tx\_output\_20b) must be asserted at a 27 MHz rate, as shown in Figure 11. Thus they must be asserted with a 5/6/5/6 clock cycle cadence. Any other cadence of the ce signals causes the SD-SDI bit replication logic to underflow or overflow. The din\_rdy ports of both modules must always be held High in SD-SDI mode.

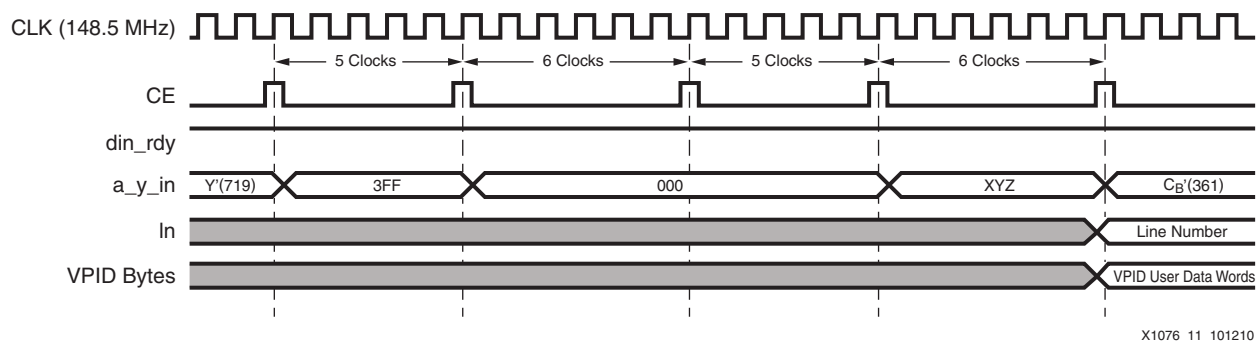

Figure 11: SD-SDI TX Timing

Notes relevant to Figure 11:

1. clk, ce, din\_rdy, and In are connected to the corresponding ports of both the triple\_sdi\_vpid\_insert and triple\_sdi\_tx\_output\_20b modules. All inputs except ce have an entire sample time in which to become stable. Data is only sampled on

the inputs on the rising edge of clk when ce is High. The sample time is the time between rising edges of clk when ce is High. As shown in Figure 11, the ce signal must always have a 5/6/5/6 clock cycle cadence. Any other cadence underflows or overflows the SDI bit replication logic. Although Figure 11 shows that the first word of the EAV is a 5-clock cycle sample, there is no such relationship required. The first word of the EAV could instead be a 6-clock cycle sample.

2. In SD-SDI mode, the line number value on the In input port is only used by the triple\_sdi\_vpid\_insert module, must be stable starting with the XYZ word of the EAV, and must remain valid through the entire HANC interval.
3. The VPID input bytes on the input of the triple\_sdi\_vpid\_insert module must be stable beginning with the XYZ word of the EAV, and must remain stable during the entire HANC interval on lines where SMPTE 352 packets are inserted.

The triple\_sdi\_vpid\_insert module optionally inserts SMPTE 352 VPID packets and outputs the modified data stream to the triple\_sdi\_tx\_output\_20b module on the ds1a connection.

The triple\_sdi\_tx\_output\_20b module inserts EDH packets, if insert\_edh is High, then the module scrambles the data and replicates each scrambled bit 11 times. The scrambled and replicated data is output on the txdata port as 20-bit words at 148.5 MHz. This data goes through the gtp\_interface\_pll module to the TXDATA port. The GTP transmitter serializes the data for transmissions over the serial interface.

Line number values input on the In\_a port of the triple\_sdi\_vpid\_insert module are only required if SMPTE 352 packets are inserted in SD-SDI mode. Line number values are not required to be input on the In\_a port of the triple\_sdi\_tx\_output\_20b module in SD-SDI mode.

### HD-SDI Transmitter Operation

When operating in HD-SDI mode, the pipe\_clk output from the gtp\_interface\_tx module has a frequency of 74.25 MHz or 74.25/1.001 MHz. The ce and din\_rdy inputs to the datapath modules must always be High. Figure 12 shows the timing of the input signals for HD-SDI mode.

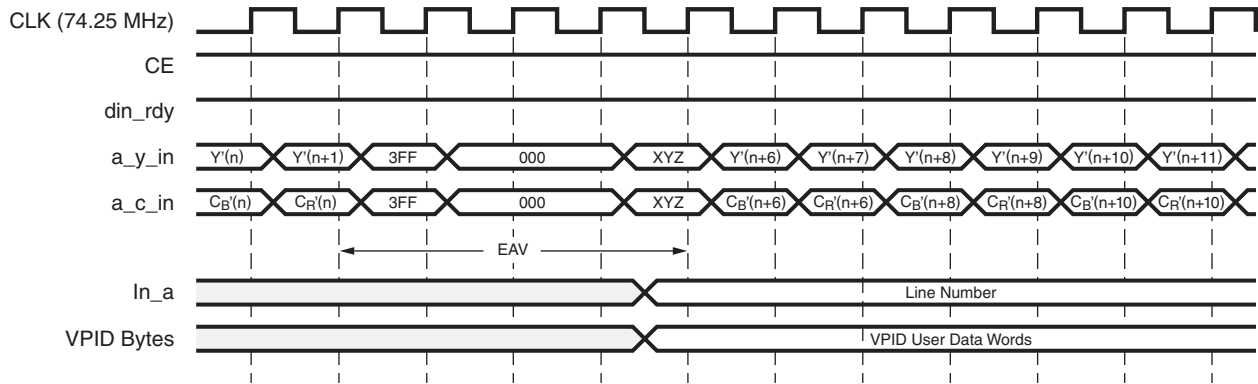

Figure 12: HD-SDI TX Timing

Notes relevant to Figure 12:

1. In HD-SDI mode, the line number value on the In\_a input port is used by both the triple\_sdi\_vpid\_insert and the triple\_sdi\_tx\_output\_20b modules and must be stable starting with the XYZ word of the EAV, and must remain valid through the entire HANC interval.

- The VPID input bytes on the input of the `triple_sdi_vpid_insert` module must be stable beginning with the XYZ word of the EAV, and must remain stable during the entire HANC interval on lines where SMPTE 352 packets are inserted.

Data enters the `triple_sdi_vpid_insert` module as two 10-bit data streams with the Y data stream on the `a_y_in` port and the C data stream on the `a_c_in` port. The input data rate is 74.25 MHz or 74.25/1.001 MHz. The `triple_sdi_vpid_insert` module optionally inserts SMPTE 352 VPID packets into the Y data stream before outputting the two data streams on the `ds1a` and `ds2a` ports to the `triple_sdi_tx_output_20b` module.

The `triple_sdi_tx_output_20b` module inserts line numbers into both data streams immediately after the EAV, if `insert_ln` is High. It calculates and inserts CRC values immediately after the line numbers if `insert_crc` is High. It scrambles the data streams and outputs one 20-bit data stream running at 74.25 MHz or 74.25/1.001 MHz on the `txdata` output port. This data passes through the `gtp_interface_pll` module and through to the GTP TXDATA port. The GTP transmitter serializes the data for transmissions over the serial interface.

Line numbers must be supplied on the `ln_a` port of the `triple_sdi_vpid_insert` module if SMPTE 352 packet insertion is enabled in HD-SDI mode. Line numbers must be supplied on the `ln_a` port of the `triple_sdi_tx_output_20b` module if line number insertion is enabled.

### 3G-SDI Transmitter Operation

When operating in 3G-SDI mode, the datapath modules can either run in level A mode or level B mode as selected by the `triple_sdi_vpid_insert` module's level input (level A = Low, level B = High). The `triple_sdi_vpid_insert` module informs the `triple_sdi_tx_output_20b` module which level is selected through the `out_mode` port.

#### Level A Mode

In 3G-SDI level A mode, the `triple_sdi_vpid_insert` module requires two 10-bit data streams on the `a_y_in` (data stream 1) and `a_c_in` (data stream 2) input ports. The clock frequency is 148.5 MHz or 148.5/1.001 MHz. The clock enable and `din_rdy` inputs to the datapath modules must be High. For 1080p 50 Hz, 59.94 Hz, and 60 Hz, the Y component data stream is input on the `a_y_in` port and the C component data stream is input on the `a_y_in` port. For all other 3G-SDI video formats, the video must be mapped to the two SDI data streams before they go into the `triple_sdi_vpid_insert` module.

Figure 13 shows the timing of the inputs signals for 3G-SDI level A mode.

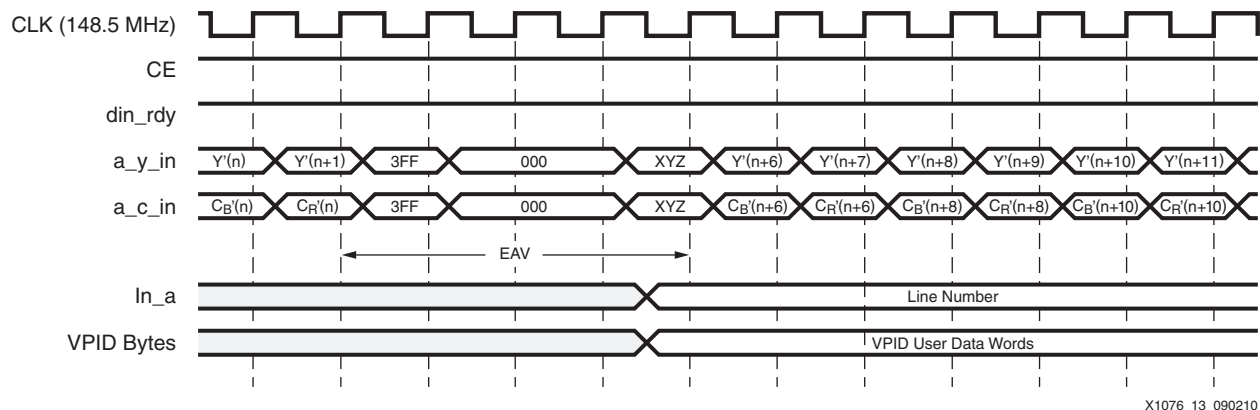

Figure 13: 3G-SDI Level A TX Timing

Notes relevant to Figure 13:

- In 3G-SDI level A mode, the line number value on the `ln` input port is used by both the `triple_sdi_vpid_insert` and the `triple_sdi_tx_output_20b` modules. It must

be stable starting with the XYZ word of the EAV, and must remain valid through the entire HANC interval.

- The VPID input bytes on the input of the `triple_sdi_vpid_insert` module must be stable beginning with the XYZ word of the EAV, and must remain stable during the entire HANC interval on lines where SMPTE 352 packets are inserted.

The `triple_sdi_vpid_insert` module inserts SMPTE 352 packets into both data streams, before outputting the data streams on the `ds1a` and `ds2a` output ports to the `triple_sdi_tx_output_20b` module. The `triple_sdi_tx_output_20b` module inserts line numbers into both data streams immediately after the EAV, if `insert_ln` is High. It calculates and inserts CRC values immediately after the line numbers if `insert_crc` is High. It scrambles the data streams and outputs one 20-bit data stream running at 148.5 MHz on the `txdata` output port. This data goes through the `gtp_interface_pll` module to the TXDATA port of the GTP transmitter. The GTP transmitter serializes the data for transmissions over the serial interface.

Line numbers are required on the `ln_a` port of the `triple_sdi_vpid_insert` module if SMPTE 352 packet insertion is enabled. However, SMPTE 352 packets are required in 3G-SDI mode. Line numbers are required on the `ln_a` port of the `triple_sdi_tx_output_20b` module if line number insertion is enabled.

### Level B Mode

When running in SG-SDI level B mode, the `triple_sdi_vpid_insert` module requires four 10-bit data streams on its `a_y_in` (Y channel of link A), `a_c_in` (C channel of link A), `b_y_in` (Y channel of link B), and `b_c_in` (C channel of link B) ports. These four data streams can be SMPTE 372 dual-link HD-SDI data streams, or they can be two independent HD-SDI streams that are to be combined onto a single 3G-SDI level B link. The clock frequency is 148.5 MHz or 148.5/1.001 MHz, therefore, the datapath modules must be clocked every other clock cycle in 3G-SDI level B mode, as shown in Figure 14. For the `triple_sdi_vpid_insert` module, either `ce` or `din_rdy` can be used to enable this module every other clock cycle. However, for the `triple_sdi_output_20b` module, `ce` cannot be used and `din_rdy` must be used. Thus, in 3G-SDI B mode, the correct way to control these modules is to keep `ce` High and toggle the `din_rdy` signal every other clock cycle, as shown in Figure 14.

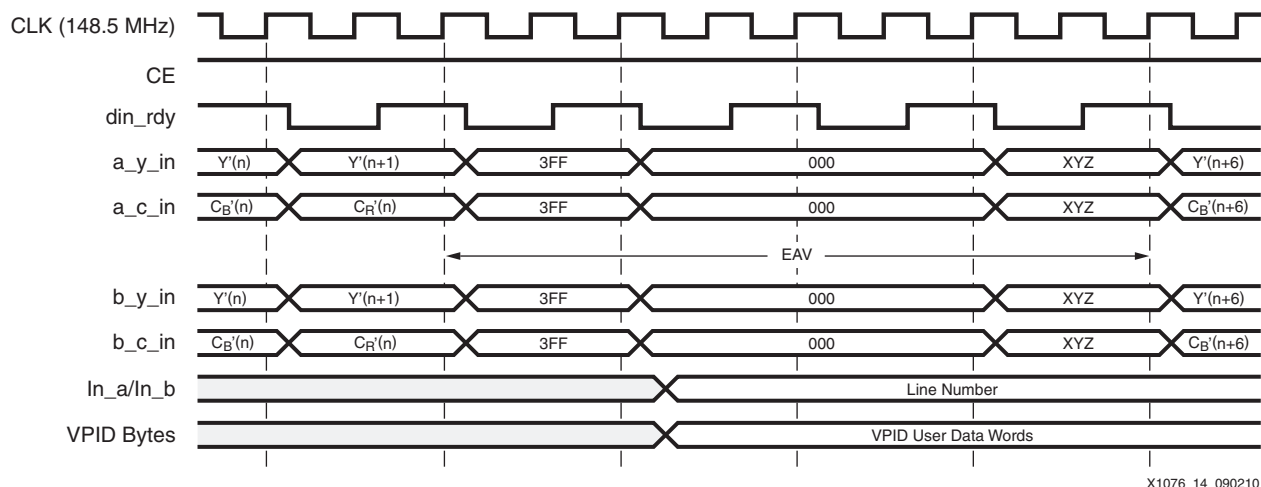

Figure 14: 3G-SDI Level B TX Timing

Notes relevant to Figure 14:

- In 3G-SDI mode, the line number value on the `ln_a` and `ln_b` input ports is used by both the `triple_sdi_vpid_insert` and the `triple_sdi_tx_output_20b` modules. It must be stable starting with the XYZ word of the EAV, and must remain valid through the entire HANC interval.

2. The VPID input bytes on the input of the `triple_sdi_vpid_insert` module must be stable beginning with the XYZ word of the EAV, and must remain stable during the entire HANC interval on lines where SMPTE 352 packets are inserted.

The `triple_sdi_vpid_insert` module inserts SMPTE 352 VPID packets in the Y data streams of both link A and link B. The four data streams are output to the `triple_sdi_tx_output_20b` module on the ds1a, ds2a, ds1b, and ds2b ports.

If `insert_in` is High, the `triple_sdi_tx_output_20b` module inserts line numbers into all four data streams. If `insert_crc` is High, it calculates and inserts CRC values immediately after the line numbers in all four data streams. The data streams are then interleaved to produce a single 20-bit data stream running at 148.5 MHz or 148.5/1.001 MHz on the txdata output port. The GTP transmitter serializes the data for transmissions over the serial interface.

If SMPTE 352 packets are to be inserted, line numbers are required on both the `In_a` (for link A) and `In_b` (for link B) input ports of the `triple_sdi_vpid_insert` module. SMPTE 352 packets are mandatory for 3G-SDI. If line number insertion is enabled, line numbers are also required on the `In_a` and `In_b` ports of the `triple_sdi_tx_output_20b` module. Two different line number ports are provided for the case where two independent HD-SDI signals are carried by 3G-SDI level B. When dual-link HD-SDI is carried by 3G-SDI level B, `In_a` and `In_b` must be driven with identical line numbers. And, for video formats where the picture line number and the transport line number are not the same, the line numbers must always be transport line numbers.

### Dual-Link HD-SDI Transmitter Operation

The triple-rate SDI transmitter does not contain the formatting logic to map the various video formats into SMPTE 372 dual-link HD-SDI streams. However, formatted SMPTE 372 dual-link HD-SDI streams can be transmitted by a pair of triple-rate SDI transmitters. There are several ways to build a dual-link HD-SDI transmitter, capable of transmitting preformatted dual-link HD-SDI streams, using the modules that make up the Spartan-6 FPGA triple-rate SDI transmitter.

The two transmitters are always paired as a dual-link HD-SDI pair. In this method, shown in [Figure 15](#), the Link A transmitter can be used in any SDI mode, but the Link B transmitter is only used in dual-link HD-SDI mode. A single `triple_sdi_vpid_insert` module inserts SMPTE 352 packets into the Y stream of both HD-SDI links of the dual-link pair. These four data streams out of the VPID inserter are connected to two `triple_sdi_tx_output_20b` modules with the link A data streams going to one output module and the link B data streams going to the other, as shown in [Figure 15](#). The link B data streams are also routed to the Link A output module because they are required for 3G-SDI level B operation.

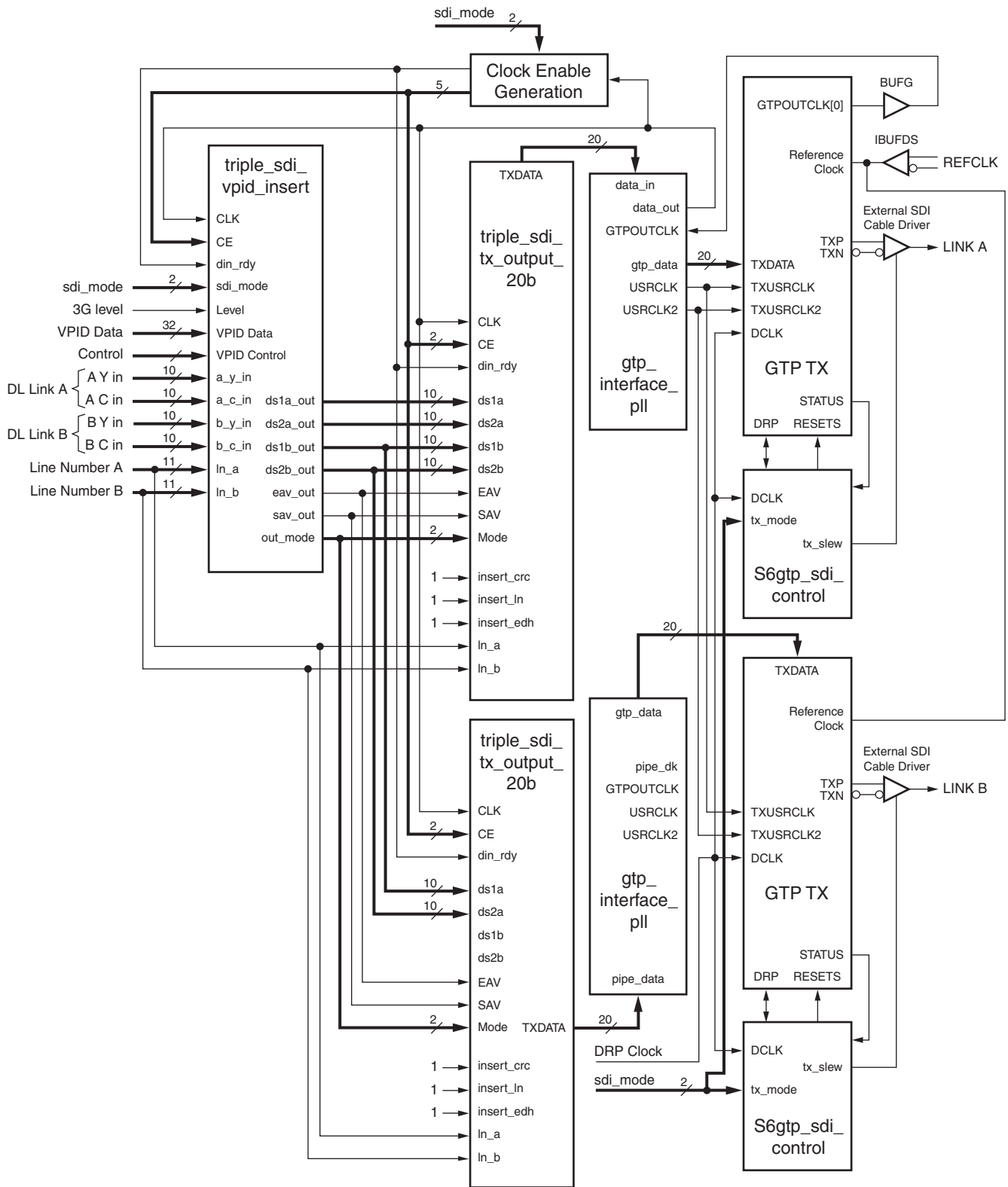

X1076\_15\_120210

Figure 15: Example Dual-Link HD-SDI TX (Transmitters Always Paired)

The input timing is identical to normal HD-SDI mode as shown in Figure 10. The In\_b line number port of the triple\_sdi\_vpid\_insert module(s) is ignored in dual-link HD-SDI mode. The In\_b port is only used in 3G-SDI level B mode.

As required by the SMPTE 372 standard, the two HD-SDI links must be uniquely identified using bit 6 of byte 4 of the SMPTE 352 packets. This bit must be 0 in link A and 1 in link B. If a single VPID insert module is used as shown in [Figure 15](#), the `triple_sdi_vpid_insert` module has separate input ports for byte 4 for the two links just for this purpose.

### Summary of Triple-Rate TX Modes

The input data rates and connections for all SDI modes are summarized in [Table 9](#).

Table 9: Triple-Rate SDI TX Modes

| SDI Mode                    | Level | TXOUTCLK                     | ce              | din_rdy                          | Input Data Rate              | a_y_in        | a_c_in        | b_y_in      | b_c_in      |
|-----------------------------|-------|------------------------------|-----------------|----------------------------------|------------------------------|---------------|---------------|-------------|-------------|
| HD-SDI and Dual-Link HD-SDI | X     | 74.25 MHz or 74.25/1.001 MHz | High            | High                             | 74.25 MHz or 74.25/1.001 MHz | Y             | C             |             |             |
| SD-SDI                      | X     | 148.5 MHz                    | 5/6/5/6 Cadence | High                             | 27 MHz                       | Y/C           |               |             |             |
| 3G-SDI A                    | 0     | 148.5 MHz or 148.5/1.001 MHz | High            | High                             | 148.5 MHz or 148.5/1.001 MHz | Data Stream 1 | Data Stream 2 |             |             |
| 3G-SDI B                    | 1     | 148.5 MHz or 148.5/1.001 MHz | High            | Asserted every other clock cycle | 74.25 MHz or 74.25/1.001 MHz | Link A<br>Y   | Link A<br>C   | Link B<br>Y | Link B<br>C |

### Triple-Rate TX Details

This section provides some additional details about the operation of the Spartan-6 FPGA triple-rate SDI transmitter reference design.

#### SMPTE 352 Packet Insertion

The `triple_sdi_vpid_insert` module can insert SMPTE 352 video payload ID packets into SD-SDI, HD-SDI, dual-link HD-SDI, and 3G-SDI (both level A and level B) streams. The dual-link HD-SDI and 3G-SDI standards require SMPTE 352 packets in the data streams. The packets are optional in SD-SDI and HD-SDI data streams.

The `triple_sdi_vpid_insert` module is a wrapper around a pair of `SMPTE352_vpid_insert` modules. The behavior of this module is the same as the behavior of the underlying `SMPTE352_vpid_insert` module. Refer to Chapter 26 of *Audio/Video Connectivity Solutions for Virtex-5 FPGAs* [Ref 3] to review the behavior of this module. This chapter also describes the required values for the user data words of the SMPTE 352 packets.

SMPTE 352 packets are inserted on one designated video line in each frame if the transport is progressive, and one designated video line in each field if the transport is interlaced. The designated video lines that carry SMPTE 352 packets vary depending on the SDI mode and the video format. They are detailed in Chapter 26 of *Audio/Video Connectivity Solutions for Virtex-5 FPGAs* [Ref 3]. The `line_f1` input port determines the line in the progressive frame or in the first interlaced field where the module inserts a SMPTE 352 packet. The `line_f2` input port determines the line in the second interlaced field where the module inserts the SMPTE 352 packet. The `line_f2_en` input determines whether packets are inserted in the line specified by `line_f2`. The `line_f2_en` input must be Low for a progressive transport and High for an interlaced transport.

The `line_f2_en` input to the `triple_sdi_vpid_insert` module must be controlled correctly. This input must be High for interlaced video and Low for progressive video. However, this input must be controlled based on whether the transport is interlaced or progressive, not the picture. The 1080p 50 Hz and 60 Hz 4:2:2 10-bit video formats, when carried by dual-link HD-SDI or 3G-SDI level B (but not 3G-SDI level A) are transported in an interlaced manner, even though the picture is progressive. The same is true for progressive segmented frame transport. It is

essential that the SMPTE 352 packets are inserted into both fields of the transport data streams for these formats. Some receiving equipment fail to lock properly if the SMPTE 352 packets are only present in one field rather than in both fields of interlaced transports.

Dual-link HD-SDI data streams coming from a dual-link SDI receiver can already have SMPTE 352 packets in the Y data streams of each link, because SMPTE 372 mandates these packets. If the packets are present, the first user data word should be hex 87 indicating that the data streams are carried on a dual-link HD-SDI interface. If these dual-link data streams are to be retransmitted on a 3G-SDI level B interface, the first user data word of the packet must be replaced with a value of hex 8A, indicating a SMPTE 372 signal carried on a 3G-SDI level B interface. Thus the SMPTE 352 packets must be modified when sending the dual-link HD-SDI streams on a 3G-SDI level B interface. Only the first byte of the VPID data must be modified. The values of the other bytes do not need to change. However, they must be captured first and applied to the VPID byte inputs of the `triple_sdi_vpid_insert` module so that they are re-inserted when the packet is overwritten by the `triple_sdi_vpid_insert` module (as part of the process of updating the packet). This is because the inserter overwrites the entire packet, not just the first user data word.

In 3G-SDI level B mode, the two independent HD-SDI signals can be carried by the 3G-SDI level B interface (called dual stream mode). These two HD-SDI signals can be vertically unsynchronized (not frame locked). If this is the case, then SMPTE 352 packets are inserted independently on the two HD-SDI signals carried by the 3G-SDI level B interface. The second line number input port on the `triple_sdi_vpid_insert` module allows two separate line numbers to be provided for level B, one for each HD-SDI signal. As there is only one set of VPID data inputs to the insertion module, the SMPTE 352 packets, with the exception of byte 4, are identical. Thus the two HD-SDI streams must be carrying identical video formats. This is normally the case because of the restrictions in 3G-SDI level B mode requiring the two HD-SDI streams have the same format. If an application requires insertion of different VPID packets into the two HD-SDI signals carried by a 3G-SDI level B signal, the `triple_sdi_vpid_insert` module must be modified to provide two completely independent sets of VPID input data ports.

### Line Number Insertion

3G-SDI and HD-SDI both require line numbers in the two words that follow each EAV. If the `insert_In` input is High, the `triple_sdi_tx_output_20b` module inserts those line numbers appropriately for HD-SDI and both levels of 3G-SDI (inserting them into all four data streams for level B 3G-SDI). The line numbers to be inserted are provided to the `triple_sdi_tx_output_20b` module on the `In_a` and `In_b` inputs. In some cases, it might not be necessary or desirable to overwrite line numbers that are already present in the data streams. In that case, the `insert_In` input can be driven Low, and no line numbers are inserted. If the `insert_In` input is hardwired Low in the source code, the line number insertion logic is optimized out of the design by the synthesis tool.

For dual-link HD-SDI data streams carried either by dual-link HD-SDI or 3G-SDI level B, if the video format is 1080p 50 Hz, 59.94 Hz, or 60 Hz, the line numbers are required to be transport line numbers, not video line numbers.

For HD-SDI, dual-link HD-SDI, and 3G-SDI level A formats, only the line number on `In_a` is used. For 3G-SDI level B, the line number on `In_a` is inserted into the Y and C data streams of link A and the line number on `In_b` is inserted into the Y and C data streams of link B (again, only if `insert_In` is asserted). For dual-link HD-SDI, two `triple_sdi_tx_output_20b` modules are used, one for each link. Each `triple_sdi_tx_output_20b` module processes its HD-SDI data streams through the `ds1a` and `ds2a` input ports, just as for normal HD-SDI mode. The `In_b` input port is not used in dual-link HD-SDI mode.

### CRC Generation and Insertion

Both 3G-SDI and HD-SDI modes require CRC values in the two words that follow the line numbers after the EAV. If the `insert_crc` input is High, the `triple_sdi_tx_output_20b` module calculates and inserts CRC values for each line for HD-SDI and both levels of 3G-SDI

(inserting them into all four data streams for level B 3G-SDI). In some cases, it might not be necessary or desirable to overwrite the CRC values already present in the data stream. In that case, the `insert_crc` input can be driven Low, and no CRC values are inserted. If the `insert_crc` input is hardwired Low, the CRC generation and insertion logic is optimized out of the design by the synthesis tool.

### EDH Generation and Insertion

EDH packets are optional, but usually present, in SD-SDI. They are never used for HD-SDI and 3G-SDI. The EDH packets contain CRC values that can be used to detect errors in the SD-SDI data stream. When running in SD-SDI mode, the `triple_sdi_tx_output_20b` module generates and inserts EDH packets when `insert_edh` is High. If `insert_edh` is hardwired Low, the synthesis tool optimizes the EDH generator out of the design. Xilinx has two different EDH processor designs. These are documented in Chapters 6 and 7 of *Audio/Video Connectivity Solutions for Virtex-II Pro and Virtex-4 FPGAs* [Ref 1]. Although originally written for Virtex-II Pro FPGAs, both of these EDH processors can be used in the Spartan-6 FPGA triple-rate SDI reference design without any modifications. The EDH processor described in Chapter 6 is used, by default, in the `triple_sdi_tx_output_20b` module, but can be replaced with the EDH processor described in Chapter 7 by modifying the `triple_sdi_tx_output_20b` module.

### Ancillary Data Insertion

Ancillary data packets can be inserted into the data streams prior to the `triple_sdi_vpid_insert` module or between the `triple_sdi_vpid_insert` module and the `triple_sdi_tx_output_20b` module. Because the SMPTE 352 packets inserted by the `triple_sdi_vpid_insert` module must go, according to the SMPTE 352 standard, at the beginning of the HANC space (immediately after the CRC words following the EAV), and ancillary data packets can get inserted on the same lines as the SMPTE 352 packets, it is better to insert the ancillary data packets after the `triple_sdi_vpid_insert` module, unless space is reserved for the SMPTE 352 packets.

The `triple_sdi_tx_output_20b` module inserts EDH packets in SD-SDI mode, if enabled. Any ancillary data packets that conflict with the standard EDH packet locations are partially or completely overwritten when the EDH packets are inserted.

### Reference Clocks and Reference Clock Switching

The Spartan-6 FPGA GTP transmitters require two different reference clock frequencies to transmit all of the SDI bit rates. These reference clock frequencies are typically 74.25 MHz and 74.25/1.001 MHz (or 2X or 4X times these two frequencies). In SD-SDI mode, it is important to always use 74.25 MHz (or a multiple) and never 74.25/1.001 MHz (or multiples).

There are two ways to switch between these two reference clock frequencies. The first is to provide a single external reference clock to the Spartan-6 FPGA GTP transmitter and change the frequency of the reference clock externally. A more flexible approach is to provide both reference clock frequencies to the Spartan-6 FPGA GTP transmitter and use the PLL reference clock multiplexer to dynamically switch between these two reference clock frequencies. The TXPLLREFSELDY input port on the GTP transceiver wrapper dynamically controls the reference clock multiplexer.

The GTP transmitter must always be reset after the reference clock frequency is changed. This ensures that the PMA PLL locks correctly to the new reference clock frequency. Regardless of whether the reference clock is changed externally or by changing the reference clock multiplexer, the GTPRESET input of the GTP transmitter must be briefly asserted High to reset the GTP transmitter after the reference clock frequency has changed. Unlike many other resets associated with the GTP transmitter, this reset is not automatically handled by the `s6gtp_sdi_control` module because it does not know when the reference clock frequency changes. The `s6gtp_sdi_control` module has a `gtpreset` port that must be connected to the GTPRESET port of the GTP transceiver wrapper, but this signal does not reset the GTP

transmitter when the reference clock frequency changes. However, a signal indicating a reference clock frequency change can be connected to the `gtp_resetrn_in` port of the `s6gtp_sdi_control` module. The `s6gtp_sdi_control` module ORs this input with its other internal GTP transmitter reset conditions to drive the `gtpreset` port.

Use of the GCLK reference clocks are not recommended for SDI transmitter applications because of jitter concerns. If necessary, GCLK reference clocks can be used to supply a reference clock to SDI receivers because the additional jitter on the reference clock has less impact on the performance of the CDR than it does on the transmitter output jitter.

### Electrical Interface

The GTP TX outputs are not directly compatible with the SDI electrical requirements. An SDI cable driver is required to interface the GTPTX output to the SDI connector. AC coupling is usually required between the GTP TX outputs and the SDI cable driver inputs. The value of these AC coupling capacitors is typically 4.7  $\mu$ F.

## SDI GTP Transceiver Control Module

The `s6gtp_sdi_control` module provides a number of functions primarily associated with control and monitoring of the Spartan-6 FPGA GTP transceiver. These control and monitoring functions are essential to reliable operation of the GTP transceiver when implementing SDI interfaces. [Table 10](#) describes the ports of the `s6gtp_sdi_control` module, and, [Table 11](#) lists the parameters of the `s6gtp_sdi_control` module.

One `s6gtp_sdi_control` module is required for each GTP transceiver dual tile. The module contains separate ports for each receiver and transmitter in each lane of the tile. If only the receiver section of the GTP transceiver is used, the transmitter ports do not need to be connected to the GTP transceiver. If only the transmitter section of the GTP transceiver is used, the receiver ports do not need to be connected to the GTP transceiver. However, the DRP ports must always be connected to the GTP transceiver because the DRP is used for both receive and transmit control functions.

Table 10: I/O Ports of the `s6gtp_sdi_control` Module

| Port Name                  | I/O | Width | Description   |
|----------------------------|-----|-------|---|
| <b>DRP and Reset Ports</b> |     |       |   |
| <code>rate_refclk</code>   | In  | 1     | This must be driven by a stable, constant frequency reference clock. It is used as a comparison frequency by the rate detector. The minimum frequency is 27 MHz. Any higher frequency can be used, up to the point where timing cannot be met. This reference clock frequency does not have to be, in any way, related to the video clock frequency. It must, however, be a constant frequency, never changing even when the SDI mode changes.<br>The rate of this clock is specified with the <code>RATE_REFCLK_FREQ</code> parameter. |
| <code>rx0_usrclk</code>    | In  | 1     | The user connects this port to the global or regional clock that is also connected to the <code>USRCLK2</code> input of <code>RX0</code> of the GTP transceiver tile.   |
| <code>rx1_usrclk</code>    | In  | 1     | The user connects this port to the global or regional clock that is also connected to the <code>USRCLK2</code> input of <code>RX1</code> of the GTP transceiver tile.   |
| <code>tx0_usrclk</code>    | In  | 1     | The user connects this port to the global or regional clock that is also connected to the <code>USRCLK 2</code> input of <code>TX0</code> of the GTP transceiver tile.  |
| <code>tx1_usrclk</code>    | In  | 1     | The user connects this port to the global or regional clock that is also connected to the <code>USRCLK2</code> input of <code>TX1</code> of the GTP transceiver tile.   |

Table 10: I/O Ports of the s6gtp\_sdi\_control Module (Cont'd)

| Port Name   | I/O | Width | Description  |
|---|-----|-------|--|
| <b>Mode Selection and Reference Clock Selection &amp; Routing</b> |     |       |  |
| rx0_mode  | In  | 2     | Selects the operating mode for RX0: <ul style="list-style-type: none"> <li>• 00: HD-SDI</li> <li>• 01: SD-SDI</li> <li>• 10: 3G-SDI</li> <li>• 11: Invalid</li> </ul>  |
| rx1_mode  | In  | 2     | Selects the operating mode for RX1: <ul style="list-style-type: none"> <li>• 00: HD-SDI</li> <li>• 01: SD-SDI</li> <li>• 10: 3G-SDI</li> <li>• 11: Invalid</li> </ul>  |
| tx0_mode  | In  | 2     | Selects the operating mode for TX0: <ul style="list-style-type: none"> <li>• 00: HD-SDI</li> <li>• 01: SD-SDI</li> <li>• 10: 3G-SDI</li> <li>• 11: Invalid</li> </ul>  |
| tx1_mode  | In  | 2     | Selects the operating mode for TX1: <ul style="list-style-type: none"> <li>• 00: HD-SDI</li> <li>• 01: SD-SDI</li> <li>• 10: 3G-SDI</li> <li>• 11: Invalid</li> </ul>  |
| <b>Cable Driver Slew Rate Control</b>                             |     |       |  |
| tx0_slew  | Out | 1     | Slew rate control for the cable driver for TX0. This output is High for SD-SDI and Low for HD-SDI and 3G-SDI.  |
| tx1_slew  | Out | 1     | Slew rate control for the cable driver for TX1. This output is High for SD-SDI and Low for HD-SDI and 3G-SDI.  |
| <b>Receiver Rate Detection</b>                                    |     |       |  |
| rx0_rate  | Out | 1     | Indicates the bit rate being received by RX0. Refer to <a href="#">Table 8</a> for details.  |
| rx1_rate  | Out | 1     | Indicates the bit rate being received by RX1. Refer to <a href="#">Table 8</a> for details.  |
| <b>GTPRESET</b>   |     |       |  |
| gtp_reset0_in   | In  | 1     | When pulsed High, this input initiates a long duration GTPRESET0 pulse to the GTP transceiver tile. The duration of the pulse is controlled by the GTP transceiver reset counter. If unused, this input must be Low.                       |
| gtp_reset1_in   | In  | 1     | When pulsed High, this input initiates a long duration GTPRESET1 pulse to the GTP transceiver tile. The duration of the pulse is controlled by the GTP transceiver reset counter. If unused, this input must be Low.                       |
| clocks_stable   | In  | 1     | This input can be used to generate a GTPRESET if the reference clock is not stable. The duration of the GTPRESET pulse to the GTP transceiver tile is equal to the duration that clocks_stable is Low. If unused, this input must be High. |
| gtpreset0   | Out | 1     | The user connects this output port to the GTPRESET0 input port of the GTP transceiver tile.  |
| gtpreset1   | Out | 1     | The user connects this output port to the GTPRESET0 input port of the GTP transceiver tile.  |
| <b>RX0 Reset Signals</b>  |     |       |  |
| rx0_pcs_reset   | In  | 1     | The application can drive this input High to initiate a reset of the PCS section of RX0.   |

Table 10: I/O Ports of the s6gtp\_sdi\_control Module (Cont'd)

| Port Name                | I/O | Width | Description   |
|--------------------------|-----|-------|---|
| rx0_cdr_reset            | In  | 1     | The application can drive this input High to initiate a reset of the CDR and PCS sections of RX0.       |
| resetdone0               | In  | 1     | This input must be driven by the RESETDONE0 output of the GTP transceiver tile.                         |
| rxbufstatus0_b2          | In  | 1     | This input must be driven by bit 2 of the RXBUFSTATUS0 port of the GTP transceiver tile.                |
| rx0_fabric_reset         | Out | 1     | This output can be used to reset the FPGA logic associated with RX0.                                    |
| rxreset0                 | Out | 1     | The user connects this output port to the RXRESET0 input port of the GTP transceiver tile.              |
| rxbufreset0              | Out | 1     | The user connects this output port to the RXBUFRESET0 input port of the GTP transceiver tile.           |
| rxcdrreset0              | Out | 1     | The user connects this output port to the RXCDRRESET0 input port of the GTP transceiver tile.           |
| <b>RX1 Reset Signals</b> |     |       |   |
| rx1_pcs_reset            | In  | 1     | The application can drive this input High to initiate a reset of the PCS section of RX1.                |
| rx1_cdr_reset            | In  | 1     | The application can drive this input High to initiate a reset of the CDR and PCS sections of RX1.       |
| resetdone1               | In  | 1     | This input must be driven by the RESETDONE1 output of the GTP transceiver tile.                         |
| rxbufstatus1_b2          | In  | 1     | This input must be driven by bit 2 of the RXBUFSTATUS1 port of the GTP transceiver tile.                |
| rx1_fabric_reset         | Out | 1     | This output can be used to reset the FPGA logic associated with RX1.                                    |
| rxreset1                 | Out | 1     | The user connects this output port to the RXRESET1 input port of the GTP transceiver tile.              |
| rxbufreset1              | Out | 1     | The user connects this output port to the RXBUFRESET1 input port of the GTP transceiver tile.           |
| rxcdrreset1              | Out | 1     | The user connects this output port to the RXCDRRESET1 input port of the GTP transceiver tile.           |
| <b>TX0 Reset Signals</b> |     |       |   |
| tx0_reset                | In  | 1     | The application can drive this input High to initiate a PCS reset of the SDI transmitter TX0.           |
| txbufstatus0_b1          | In  | 1     | The user connects this input port to bit 1 of the TXBUFSTATUS0 output port of the GTP transceiver tile. |
| tx0_fabric_reset         | Out | 1     | This output can be used to reset the datapath of the SDI transmitter TX0.                               |
| txreset0                 | Out | 1     | This output must be connected to the TXRESET0 input port of the GTP transceiver tile.                   |
| <b>TX1 Reset Signals</b> |     |       |   |
| tx1_reset                | In  | 1     | The application can drive this input High to initiate a PCS reset of the TX1.                           |
| txbufstatus1_b1          | In  | 1     | The user connects this input port to bit 1 of the TXBUFSTATUS1 output port of the GTP transceiver tile. |
| tx1_fabric_reset         | Out | 1     | This output port can be used to reset the datapath of the SDI transmitter TX1.                          |
| txreset1                 | Out | 1     | This output port must be connected to the TXRESET1 input port of the GTP transceiver tile.              |

Table 10: I/O Ports of the s6gtp\_sdi\_control Module (Cont'd)

| Port Name          | I/O | Width | Description  |
|--------------------|-----|-------|--|
| <b>DRP Signals</b> |     |       |  |
| dclk               | In  | 1     | This input port must be connected to a free-running clock. The same clock signal must be connected to the DCLK input of the GTP transceiver tile. This clock input also clocks much of the reset logic, so it must be driven with a valid clock signal even if the DRP controller is not used. It is usually possible for dclk and rate_refclk to be sourced by the same clock signal. |
| drst               | In  | 1     | This is an asynchronous reset for the DRP controller. If used, it should also be connected to the DRST input of the GTP transceiver tile. A High pulse on this input causes the DRP controller to reinitialize the GTP transceiver attributes that it controls dynamically.  |
| drdy               | In  | 1     | The user connects this port to the DRDY output port of the GTP transceiver tile.   |
| drpo               | In  | 16    | The user connects this port to the DRPO output port of the GTP transceiver tile.   |
| daddr              | Out | 7     | The user connects this port to the DADDR input port of the GTP transceiver tile.   |
| den                | Out | 1     | The user connects this port to the DEN input port of the GTP transceiver tile.   |
| di                 | Out | 16    | The user connects this port to the DI input port of the GTP transceiver tile.  |
| dwe                | Out | 1     | The user connects this port to the DWE input port of the GTP transceiver tile.   |

Table 11: Parameters for the s6gtp\_sdi\_control Module

| Parameter                    | Type          | Description  |
|------------------------------|---------------|--|
| GTP_RESET_CNTR_SIZE          | Integer       | This parameter specifies the size (number of bits) of the GTP transceiver reset delay counter. This counter is reset to 0 when gtp_reset_in is 1. When gtp_reset_in goes Low, the counter starts counting and the gtpreset output signal remains at 1 until the terminal count is reached. The terminal count occurs when the MSB of the counter becomes 1. The reset counter is clocked by the dclk clock input, therefore the delay count is dclk frequency / (2 <sup>GTP_RESET_CNTR_SIZE</sup> ). |
| CBL_DISCONNECT_RST_CNTR_SIZE | Integer       | This parameter is obsolete because the cable disconnect reset is no longer needed. It is included for completeness. It used to specify the size of the cable disconnect reset duration counter in terms of DCLK cycles.  |
| RATE_REFLK_FREQ              | Integer       | This parameter specifies the frequency of the dclk in Hz. This parameter is required for the receiver rate detection logic function to work correctly. The rate detection function is an essential part of the GTP receiver reset logic. If an SDI receiver is implemented, this parameter is required to be accurate even if the rx_m rate detection output of the module is not used.  |
| PMA_RX_CFG_HD                | 25-bit vector | This value is used by the DRP controller to set the PMA_RX_CFG attribute of the GTP receiver when the receiver is placed in HD-SDI mode. The default value is normally used.   |
| PMA_RX_CFG_SD                | 25-bit vector | This value is used by the DRP controller to set the PMA_RX_CFG attribute of the GTP receiver when the receiver is placed in SD-SDI mode. The default value is normally used.   |
| PMA_RX_CFG_3G                | 25-bit vector | This value is used by the DRP controller to set the PMA_RX_CFG attribute of the GTP receiver when the receiver is placed in 3G-SDI mode. The default value is normally used.   |

Table 11: Parameters for the `s6gtp_sdi_control` Module (Cont'd)

| Parameter           | Type         | Description  |
|---------------------|--------------|--|
| PLL_RXDIVSEL_OUT_HD | 2-bit vector | This value is used by the DRP controller to set the PLL output divider for the GTP receiver when the receiver is in HD-SDI mode: <ul style="list-style-type: none"> <li>• 00: divide by 1</li> <li>• 01: divide by 2</li> <li>• 10: divide by 4</li> </ul>       |
| PLL_RXDIVSEL_OUT_SD | 2-bit vector | This value is used by the DRP controller to set the PLL output divider for the GTP receiver when the receiver is in SD-SDI mode: <ul style="list-style-type: none"> <li>• 00: divide by 1</li> <li>• 01: divide by 2</li> <li>• 10: divide by 4</li> </ul>       |
| PLL_RXDIVSEL_OUT_3G | 2-bit vector | This value is used by the DRP controller to set the PLL output divider for the GTP receiver when the receiver is in 3G-SDI mode: <ul style="list-style-type: none"> <li>• 00: divide by 1</li> <li>• 01: divide by 2</li> <li>• 10: divide by 4</li> </ul>       |
| PLL_TXDIVSEL_OUT_HD | 2-bit vector | This value is used by the DRP controller to set the PLL output divider for the GTP transmitter when the transmitter is in HD-SDI mode: <ul style="list-style-type: none"> <li>• 00: divide by 1</li> <li>• 01: divide by 2</li> <li>• 10: divide by 4</li> </ul> |
| PLL_TXDIVSEL_OUT_SD | 2-bit vector | This value is used by the DRP controller to set the PLL output divider for the GTP transmitter when the transmitter is in SD-SDI mode: <ul style="list-style-type: none"> <li>• 00: divide by 1</li> <li>• 01: divide by 2</li> <li>• 10: divide by 4</li> </ul> |
| PLL_TXDIVSEL_OUT_3G | 2-bit vector | This value is used by the DRP controller to set the PLL output divider for the GTP transmitter when the transmitter is in 3G-SDI mode: <ul style="list-style-type: none"> <li>• 00: divide by 1</li> <li>• 01: divide by 2</li> <li>• 10: divide by 4</li> </ul> |

## DRP Port

The `s6gtp_sdi_control` module must always be connected to the DRP of the GTP transceiver when a receiver is used. It dynamically changes transceiver attributes through the DRP, for the receiver, when the SDI mode changes.

The `dclk` input port serves as the master clock for the module. It synchronizes the module with the DRP of the GTP transceiver, and clocks the internal logic of the module. The `rate_refclk` port is used as part of the receiver bit rate detection logic that generates the `rx_rate` output. Because of this, the module needs to know the frequency of `rate_refclk`. The module has a parameter/generic called `RATE_REFCLK_FREQ` that specifies the frequency of `rate_refclk` in Hz. This parameter/generic must be correctly specified when the `s6gtp_sdi_control` module is instantiated, otherwise the receiver rate detection function does not work correctly.

The other parameters of the `s6gtp_sdi_control` module are used by the module's DRP controller to dynamically switch the GTP transceiver between SDI modes. These parameters must all be correctly specified for the GTP transceiver to work correctly, although the three `PMA_RX_CFG_XX` parameters are best left in the default settings, which have been optimized for best receiver jitter tolerance. Similarly, the `PLL_DIVSEL_OUT_XX` parameters have been chosen for the particular mode and should not be changed.

## Transmitter Functions

The `s6gtp_sdi_control` module provides several functions required for SDI transmitter operation. Many of the signals between the module and the GTP transceiver must be synchronous with the TX pipeclk, therefore this clock must be provided to the `s6gtp_sdi_control` module on the `txusrclk` port.

The SDI mode of the GTP transmitter is selected by the `tx_mode` input port. A change in the TX mode can be used to trigger a dynamic reconfiguration of the GTP transmitter in the reference design. The PLL post divider in the TX is changed based on `tx_mode`.

In certain circumstances, the GTP transmitter must be reset to ensure proper operation. The module asserts the `txreset_out` port to reset the GTP transmitter in these circumstances:

- When the `txreset_in` port is asserted High, the `txreset_out` port is driven High. The `txreset_in` port is typically driven by a signal that is pulsed High whenever the transmitter reference clock frequency is changed. The GTP transmitter must be reset when the frequency of the reference clock changes, either by changing the frequency of the external reference clock signal, or by changing reference clocks using the GTP transceiver PLL reference clock multiplexer. If the reference clock inputs are not stable as the FPGA emerges from configuration, the `txreset_in` port should be asserted briefly when the reference clocks become stable.
- If a GTP transmitter buffer error occurs, as indicated by the `TXBUFSTATUS[1]` bit, the GTP transmitter is reset.

The `s6gtp_sdi_control` module provides two outputs for convenience that are not required for proper operation of the SDI transmitter: `tx_rate_change_done` and `tx_slew`. The `tx_rate_change_done` output is asserted High upon completion of the dynamic TX rate change algorithm. When this output is Low, the GTP transmitter is not operating normally. The module also provides a `tx_slew` output that can be used to control the slew rate input of the external SDI cable driver.

## Receiver Functions

The `s6gtp_sdi_control` module provides several functions required for SDI receiver operation. Some of the signals between the module and the GTP transceiver must be synchronous with the RX pipeclk, therefore this clock must be provided to the `s6gtp_sdi_control` module on the `rxusrclk` port.

The SDI mode of the GTP receiver is selected by the `rx_mode` input port. Changing this input port causes the module to dynamically configure the GTP receiver for the selected SDI mode. The `triple_sdi_rx_20b` module automatically searches for the correct SDI mode whenever it is not locked to the input SDI signal. To implement this search function, the mode output of the `triple_sdi_rx_20b` module must drive the `rx_mode` input of the `s6gtp_sdi_control` module. When the SDI mode changes, the `triple_sdi_rx_20b` module changes the line rate of the GTP receiver by changing the value on the `RXRATE` port of the GTP transceiver. It also changes GTP CDR attributes through the `DRP` port.

The `triple_sdi_rx_20b` module issues a `RXCDRRESET` to the GTP transceiver under two conditions:

- `RXCDRRESET` is asserted when the receiver rate detection module detects that the input SDI bit rate has changed between the two HD-SDI bit rates or between the two 3G-SDI bit rates. This is essential to allow the CDR to lock correctly to the new bit rate.
- The `triple_sdi_rx_20b` module resets the GTP receive buffer by asserting its `rxbufreset` output, which must be connected to the `RXBUFRESET` input port of the GTP transceiver whenever there is a receive buffer error. Receive buffer errors are indicated by assertion of bit 2 of the `RXBUFSTATUS` port.

The `triple_sdi_rx_20b` module contains a bit rate detector. The bit rate detector compares the frequency of the recovered clock to the frequency of the `dclk` to determine the input SDI bit rate. The `rx_rate` output is Low if the bit rate is 1.485 Gb/s or 2.97 Gb/s, and High if it is 1.485/1.001 Gb/s or 2.97/1.001 Gb/s. The `RATE_REFCLK_FREQ` parameter/generic must be used to specify the frequency of the `rate_refclk` for the rate detection function to operate correctly. Even if the application does not use the `rx_rate` output port of the `triple_sdi_rx_20b` module, the rate detection function is still required. This is because the rate detection function is an essential part of the `RXCDRRESET` generator.

## Creating the GTP Transceiver Wrapper

GTP transceiver wrapper modules must be created to support SDI. This section describes the steps necessary to create GTP transceiver wrappers compatible with SDI interfaces.

### Running the GTP Transceiver Wizard

The Spartan-6 FPGA GTP Transceiver Wizard is used to create the GTP transceiver wrapper modules that must be instantiated into the application. The wizard can be used to create a GTP transceiver wrapper module for a single GTP transceiver tile which can then be instantiated multiple times in the design.

The wizard does not support SDI as a protocol template. Therefore the wizard must be configured manually to create the GTP transceiver wrapper for SDI. The GTP transceiver wrapper created by the wizard must also be manually edited after it is created to implement an SDI interface.

These steps describe how to create and edit the GTP transceiver wrapper for an SDI application using version 1.4 and later of the wizard.

1. The easiest way to run the wizard is to use the New Source Wizard in the ISE® software project manager, invoked by the New Source command. When the New Source Wizard starts, set the type as **IP (CORE Generator & Architecture Wizard)** and provide a file name. The file name chosen is not only used as the GTP transceiver wrapper file name, but also as the name of the GTP transceiver wrapper module. The first page of the New Source Wizard GUI is shown in [Figure 16](#).

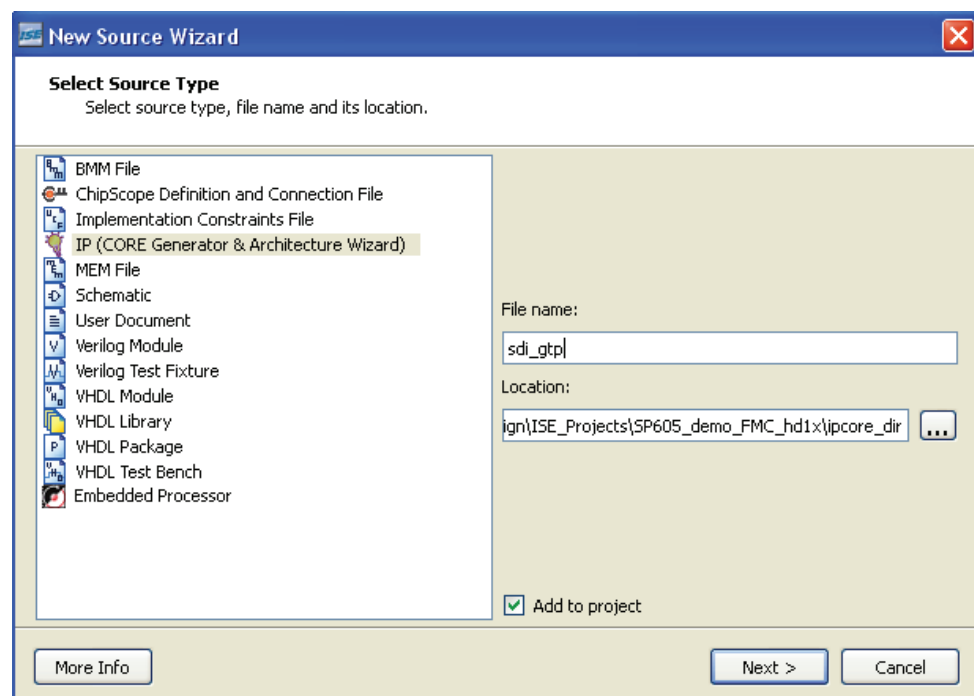

X1076\_16\_090310

Figure 16: New Source Wizard, Page 1

Checking **Add to project** adds the GTP transceiver wrapper source to the list of source files in the ISE project. This step is optional. If this option is selected, the GTP transceiver wrapper is added to the user's project source code. If this option is not selected, the two GTP transceiver wrapper source code, `filename.vhd` (or `filename.v`) and `filename_tile.vhd` (or `filename_tile.v`), files must be added to the project manually.

2. Click **Next >** to move to the second page of the New Source Wizard. Select the **Spartan-6 FPGA GTP Transceiver Wizard**, as shown in [Figure 17](#), then click **Next >** to move to the third page of the New Source Wizard.

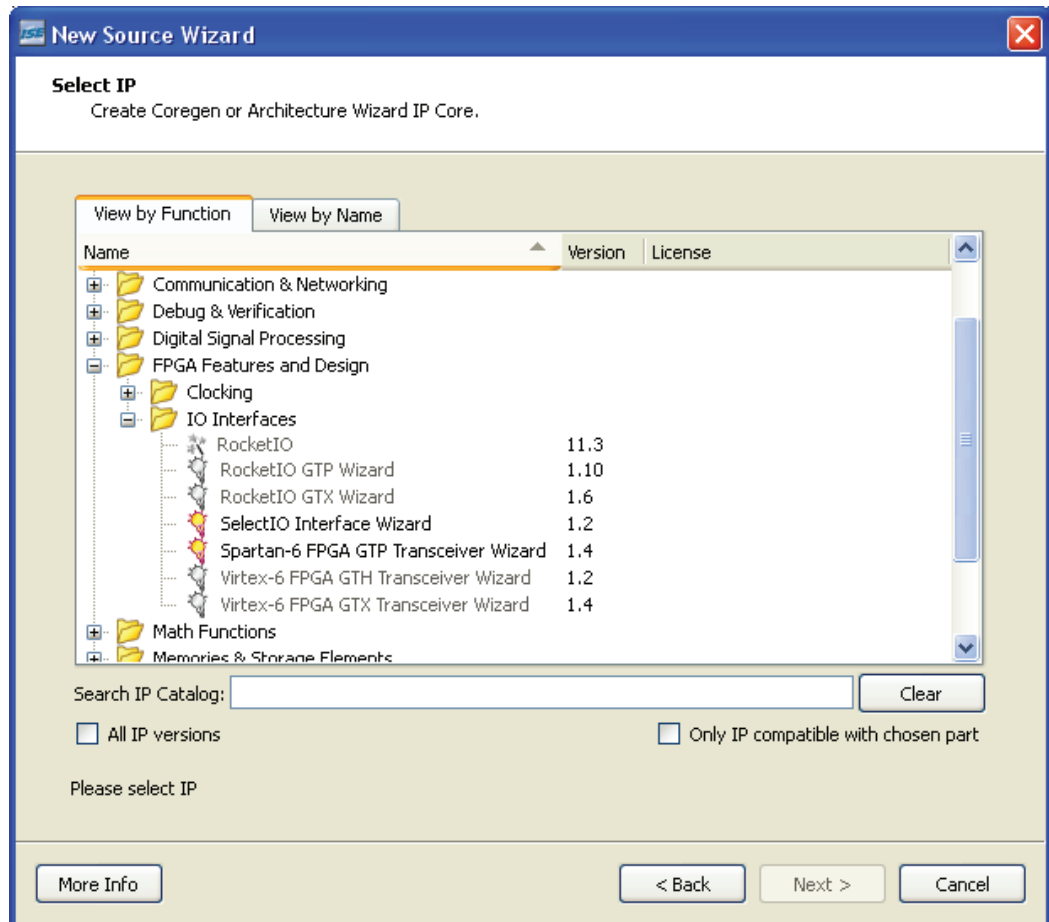

X1076\_17\_090210

Figure 17: New Source Wizard, Page 2

3. On the third page of the New Source Wizard, click **Finish** to launch the GTP Transceiver Wizard. The first page of the Spartan-6 FPGA GTP Transceiver Wizard is shown in [Figure 18](#).

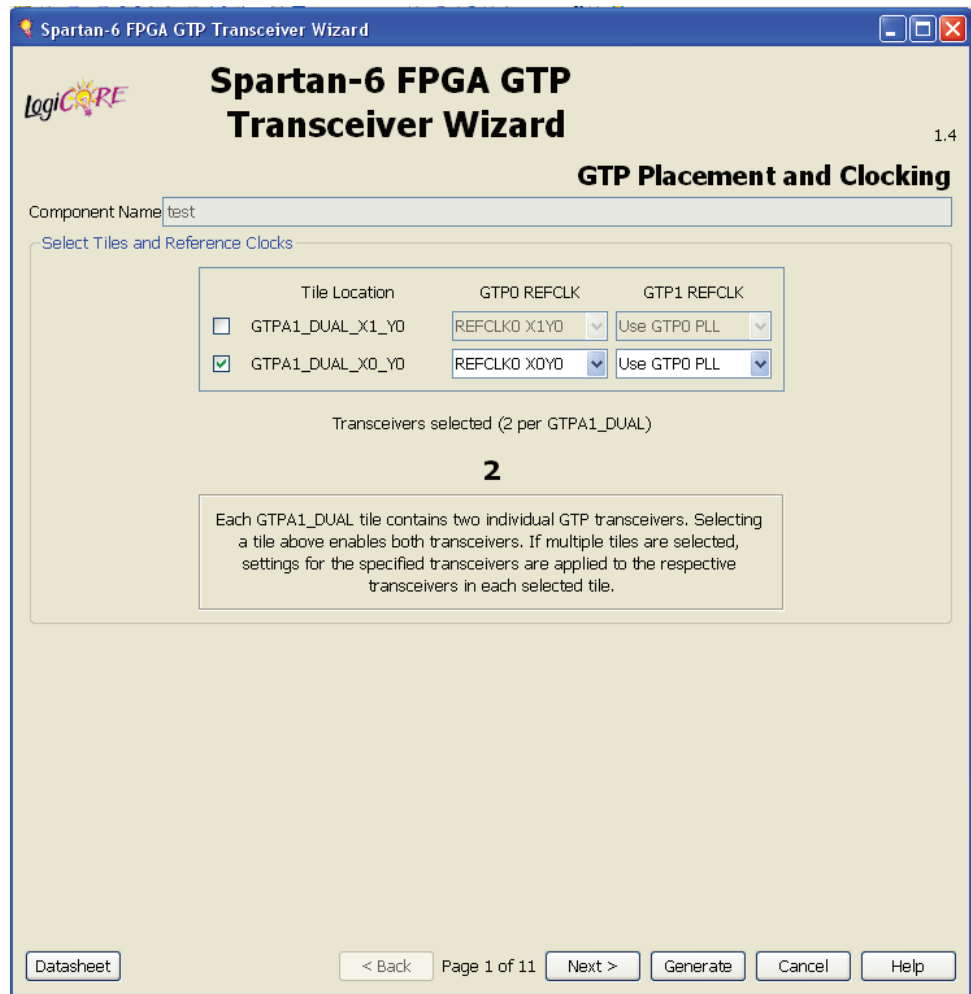

X1076\_18\_090310

Figure 18: Spartan-6 FPGA GTP Transceiver Wizard, Page 1

Table 12 lists all wizard settings pertinent to SDI and their recommended values.

Table 12: Spartan-6 FPGA GTP Transceiver Wizard Settings

| Wizard Page | Parameter                        | Recommended Setting (SDI) | Description  |
|-------------|----------------------------------|---------------------------|--|
| 1           | Tile Location                    | Application Specific      | Selects the GTP1A_DUAL tile to be used. Location origin (X0_Y0) is at upper left of die.   |
| 1           | GTP0 REFCLK                      | Application Specific      | Selects the reference clock to be used by both the transmitter and receiver. Can select clocks from adjacent tiles. <i>It is important that a reference clock input is selected for the TX clock source. The RX can use this same clock, which does not have to be synchronous to the incoming data.</i> |
| 1           | GTP1 REFCLK                      | Application Specific      | Selects the reference clock to be used by both the transmitter and receiver. Can select clocks from adjacent tiles. <i>It is important that a reference clock input is selected for the TX clock source. The RX can use this same clock, which does not have to be synchronous to the incoming data.</i> |
| 2           | Use Dynamic Reconfiguration Port | (Checked)                 | This box must be checked to use triple-rate RX. This allows parameters to be changed dynamically, for example, from SD-SDI to HD-SDI.  |

Table 12: Spartan-6 FPGA GTP Transceiver Wizard Settings (Cont'd)

| Wizard Page | Parameter             | Recommended Setting (SDI)  | Description   |
|-------------|-----------------------|--|---|
| 2           | Protocol Template     | “sdi” if available or “Start from scratch”   | This sets defaults for predefined standards such as PCI Express®. In wizard version 1.5 and later, there is an “sdi” menu option that can be used.  |
| 2           | Target Line Rate      | 1.485 Gb/s   | Sets the line rate desired for the target design. This is changed dynamically through the DRP controller.   |
| 2           | Reference Clock       | 148.5 MHz  | Selects the optimal reference clock frequency provided by the application.  |
| 2           | TX Line Rate          | 1.485 Gb/s   | Selects the target line rate. This can be independent of the receive line rate and is changed dynamically through the DRP controller.   |
| 2           | TX Encoding           | None   | Disables TX 8B/10B encoding.  |
| 2           | TX Data Path Width    | 20   | Sets the datapath interface width for the transmitter.  |
| 2           | RX Line Rate          | 2.97 Gb/s  | Selects the target line rate. This can be independent of the transmit line rate.  |
| 2           | RX Decoding           | None   | Disables RX 8B/10B decoding.  |
| 2           | RX Data Path Width    | 20   | Sets the datapath interface width for the receiver.   |
| 3           | 8B/10B Optional Ports | N/A  | None of the ports are available because 8B/10B encoding/decoding is not enabled.  |
| 4           | Enable TX Buffer      | (Checked)  | Enables the TX buffer between the parallel clock domain of the PCS to the serial clock domain of the PMA. This buffer can be disabled to minimize latency, but this generates a TX synchronizer module that requires a synchronization procedure at start-up.   |
| 4           | TXUSRCLK Source       | TXOUTCLK   | The setting is based on whether or not the TX buffer is enabled. If the TX buffer is enabled, TXOUTCLK must be selected. If it is not enabled, REFCLKOUT must be selected.  |
| 4           | Enable RX Buffer      | (Checked)  | Enables the RX buffer between the serial clock domain of the PMA and the parallel clock domain of the PCS. This buffer can be disabled to minimize latency, but this generates an RX synchronizer module that requires a synchronization procedure at start-up. |
| 4           | RXUSRCLK Source       | RXRECCLK   | The user clock from the receiver must be the recovered from the RX port. This clock is output on both the RXRECCLK port and on GTPOUTCLK[1].  |
| 4           | Optional Clock Ports  | <ul style="list-style-type: none"> <li>• RXRESET</li> <li>• RXRECCLK</li> <li>• RXBUFSTATUS</li> <li>• RXBUFRESET</li> <li>• TXOUTCLK</li> <li>• TXRESET</li> <li>• TXBUFSTATUS</li> </ul> | These ports are required to interface to the <code>s6gtp_sdi_control</code> module.   |
| 5           | Comma Detection       | (Not checked)  | Comma detection does not apply to SDI.  |
| 5           | Optional Comma Ports  | N/A  | Comma detection does not apply to SDI.  |
| 6           | Preemphasis           | 0  | This value is not critical when the SDI cable driver is located close to the FPGA. The value can be modified to meet the application requirements.  |
| 6           | Differential Swing    | 0  | This value is not critical when the SDI cable driver is located close to the FPGA. The value can be modified to meet the application requirements.  |

Table 12: Spartan-6 FPGA GTP Transceiver Wizard Settings (Cont'd)

| Wizard Page | Parameter                  | Recommended Setting (SDI)   | Description   |
|-------------|----------------------------|---|---|
| 6           | RX Equalization            | 10  | This value is not critical when the SDI cable driver is located close to the FPGA. The value can be modified to meet the application requirements.  |
| 6           | RX Termination             | <ul style="list-style-type: none"> <li>AC coupling disabled</li> <li>VTTRX for termination voltage</li> </ul> | The internal AC coupling capacitors are not large enough to handle the long run lengths of the SDI protocols. External AC coupling capacitors are used between the cable equalizer and the GTP receiver inputs. |
| 6           | Optional Termination Ports | RXCDRRESET  | This port is required to interface to the <code>s6gtp_sdi_control</code> module.  |
| 7 to 10     | (All other settings)       | N/A   | These do not apply to SDI.  |

## Manually Editing the GTP Transceiver Wrapper Files

The Spartan-6 FPGA GTP Transceiver wizard produces a family of files supporting the configuration. The `filename_tile.v` file contains the actual instantiation of the GTP transceiver tile. This is where the GTP transceiver parameters are specified and the ports are connected. In some cases, the reference clock selects, REFSELDYPLL0 and REFSELDYPLL1, do not reflect the reference clock specified in the GTP0 REFCLK and GTP1 REFCLK parameters of the wizard. Typically, REFSELDYPLL0 and REFSELDYPLL1 are set to 0 when they should have another value. The user must verify the connections of these two inputs and change the settings if necessary. Refer to Chapter 2 (Shared Transceiver Features) of *Spartan-6 FPGA GTP Transceivers User Guide* [Ref 4] for details on clock selection.

## Reference Design

The reference design files can be downloaded at <https://secure.xilinx.com/webreg/clickthrough.do?cid=154516>.

Table 13 lists the reference design matrix, which provides additional information about the design.

Table 13: Reference Design Matrix

| Parameter   | Description  |
|---|--|
| <b>General</b>  |  |
| Developer Name  | Xilinx   |
| Target Device   | Spartan-6 FPGA   |
| Source Code provided  | Yes  |
| Source Code format  | VHDL, Verilog  |
| IP used   | Yes<br>(Design uses code/IP from XAPP875 [Ref 2] and PicoBlaze™ processor) |
| <b>Simulation</b>   |  |
| Functional simulation performed                               | No   |
| Timing simulation performed                                   | No   |
| Testbench used for functional and timing simulations provided | No   |
| Testbench format  | N/A  |

Table 13: Reference Design Matrix (Cont'd)

| Parameter                               | Description                             |
|---|---|
| Simulator Software / version            | N/A                                     |
| SPICE / IBIS simulations                | No                                      |
| <b>Implementation</b>                   |   |
| Synthesis tool / version                | XST version in ISE software v12.2       |
| Implementation tool / version           | ISE software v12.2                      |
| Static Timing Analysis performed        | Yes                                     |
| <b>Hardware Verification</b>            |   |
| Hardware verified                       | Yes                                     |
| Hardware platform used for verification | SP605 demonstration board with CTXIL671 |

## FPGA Resource Usage

Table 14 shows the FPGA resources required for each of the triple-rate SDI interface reference designs described in this document. The resource usage includes all the modules required to implement the interface, including the `s6gtp_sdi_control` module.

Table 14: Triple-Rate SDI Interface FPGA Resource Usage

| Reference Design   | FFs  | LUTs | PLLs | BUFGs |
|--|------|------|------|-------|
| Triple-Rate RX (no EDH processor)                          | 485  | 416  | 1    | 2     |
| Triple-Rate RX (with EDH processor)                        | 860  | 917  | 1    | 2     |
| Triple-Rate TX (with EDH processor)                        | 2533 | 2883 | 1    | 2     |
| Triple-Rate TX (EDH processor optimized out of the design) | 2143 | 2403 | 1    | 2     |

The triple-rate SDI receiver does not include an EDH processor for SD-SDI, but an EDH processor can be connected to the outputs of the SDI receiver. Table 14 shows the size of the receiver both with and without an EDH processor. The SDI TX includes an EDH processor; however, it can be optimized out of the design by connecting the `insert_edh` input port of the `triple_sdi_tx_output_20b` module Low. Table 14 shows the size of the transmitter both with the EDH processor and with it optimized out of the design. In both the receiver and transmitter cases, the EDH processor used is described in Chapter 6 of *Audio/Video Connectivity Solutions for Virtex-II Pro and Virtex-4 FPGAs* [Ref 1].

The results shown were achieved using ISE software v12.2 with design strategy set to **area reduction strategy1**. The XST “Safe Implementation” property was set to **Yes**.

The SDI receiver and transmitter interface designs do not require any block RAMs or DSP48A1 slices.

## Timing

The maximum datapath clock frequency used in these designs is 148.5 MHz. This timing can be met in -3 and above speed grades in Spartan-6 devices. In the -2 speed grade, the GTP transceiver parallel interface rate exceeds the component switching limit.

The RXRECCLK and TXOUTCLK (GTPOUTCLK[1:0]) signals generated by the GTP transceiver can, under some conditions, have erratic timing when the input SDI bitstream stops and restarts, or when the GTP transceiver is switched between SDI modes. These periods of erratic timing can cause problems for sequential control logic, such as finite state machines. Most synthesis tools, by default, optimize away illegal state recovery for finite state machines.

The erratic timing of the GTP transceiver clocks can cause the finite state machine to go into illegal states. Therefore it is highly recommended that the synthesis tool be forced to generate “safe” implementations of finite state machines that include illegal state recovery.

Example UCF constraint files are supplied with the reference designs and can be used as examples of the timing and placement constraints required for SDI interfaces.

## SD-SDI DRU

The DRU used for recovering the SD-SDI data is not supplied in source-code form. It is supplied as a precompiled NGC file. For Verilog implementations, a wrapper file called `dru.v` defines the ports of the DRU. This wrapper file must be included in the project. The `dru.ngc` file must be placed in the project directory where the tools can find it and include it into the design. For VHDL implementations, the DRU component must be defined in the entity. See [\[Ref 2\]](#) for a description of the DRU.

---

## Conclusion

This document describes the triple-rate SDI receiver and transmitter reference designs for the GTP transceivers in Spartan-6 devices. The Spartan-6 FPGA GTP transceivers are well suited for implementing SDI interfaces, providing a high degree of performance and reliability in a low-cost device.

---

## References

This section provides links to documents referenced in this document:

1. [XAPP514](#), *Audio/Video Connectivity Solutions for Virtex-II Pro and Virtex-4 FPGAs*
2. [XAPP875](#), *Dynamically Programmable DRU for High-Speed Serial I/O*
3. [XAPP1014](#), *Audio/Video Connectivity Solutions for Virtex-5 FPGAs*
4. [UG386](#), *Spartan-6 FPGA GTP Transceivers User Guide*
5. [UG753](#), *FPGA Broadcast Mezzanine Card User Guide*

## Appendix A: Triple-Rate SDI Demonstration

The demonstration design described in this appendix incorporates both the transmitter and receiver designs for triple-rate SDI on Spartan-6 devices, and demonstrates the basic functionalities of both. The demonstration runs on a Xilinx® SP605 evaluation board connected to an FPGA broadcast mezzanine card (FMC card). Refer to [Ref 5] for a description of the FMC card.

### Setup

Figure 19 shows the basic elements of the hardware. The FMC card is connected to the SP605 board via the low pin count (LPC) FMC connector, with the FMC card on top. The FMC card receives all of its power and control from the SP605 board.

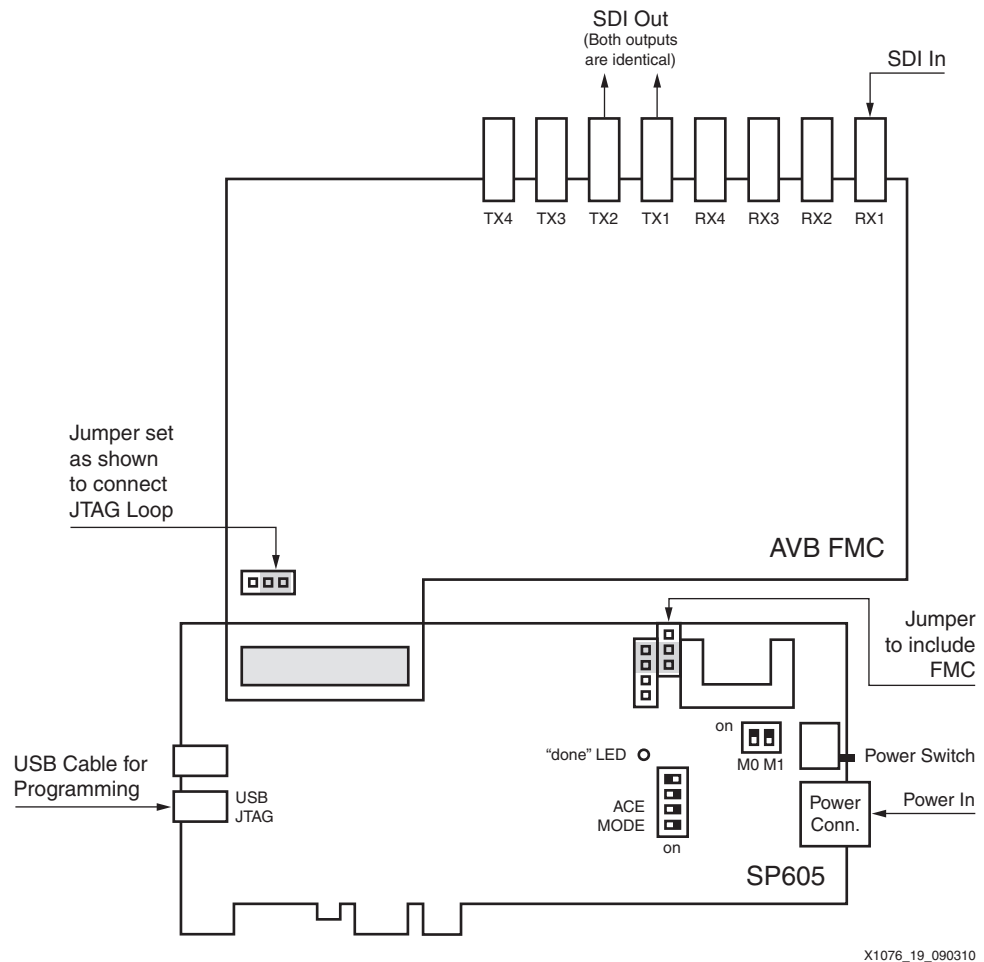

Figure 19: Triple-Rate SDI Demonstration Setup

- Two jumpers must be set up properly to include the FMC card in the JTAG shift loop:
  - FMC JTAG jumper (J19) on the SP605 board must be set to include the FMC connector in the loop.
  - JTAG CONFIG jumper (J21) on the FMC card must be set to exclude the expansion FMC connector from the loop.
- Two sets of DIP switches affect loading the Spartan-6 FPGA onto the SP605 board:
  - Mode switches (SW1) for M0 and M1 should both be set to ON.
  - The ACE MODE switch (S1) and program switches pertain to programming the FPGA from a CompactFlash card. Normally, switches 1, 2, and 3 are OFF and switch 4 is ON.

- The power cable must be plugged into the power connector, and a USB cable is plugged into the USB JTAG port to program the FPGA via JTAG.
- Video inputs and outputs are at the top of the FMC card. There are two identical transmitter outputs and one receiver input.
- The Spartan-6 FPGA on the FMC card must be preprogrammed for audio and video demonstrations. Refer to *FPGA Broadcast Mezzanine Card User Guide* [Ref 5] for more information on the FMC card.
- The Spartan-6 FPGA on the SP605 board can be programmed with the demonstration bit file via the USB JTAG port using the ChipScope™ tool. The done bit LED indicates programming status. The demonstration bit file enables both the receiver and transmitter demonstrations.

## Triple-Rate Transmitter Demonstration

The transmitter demonstrates the capability to transmit in SD-SDI, HD-SDI, and 3G-SDI modes. There are controls to set the mode select to various line standards and bit rates. Multiple test patterns can be used in the demonstration.

SD-SDI, HD-SDI, and 3G-SDI modes can be transmitted from the SDI TX1 and SDI TX2 connectors on the FMC card. Both outputs are identical. The demonstration is controlled via DIP switches and push buttons on the SP605 board. The basic elements of the hardware for the triple-rate SDI transmitter demonstration is shown in Figure 20.

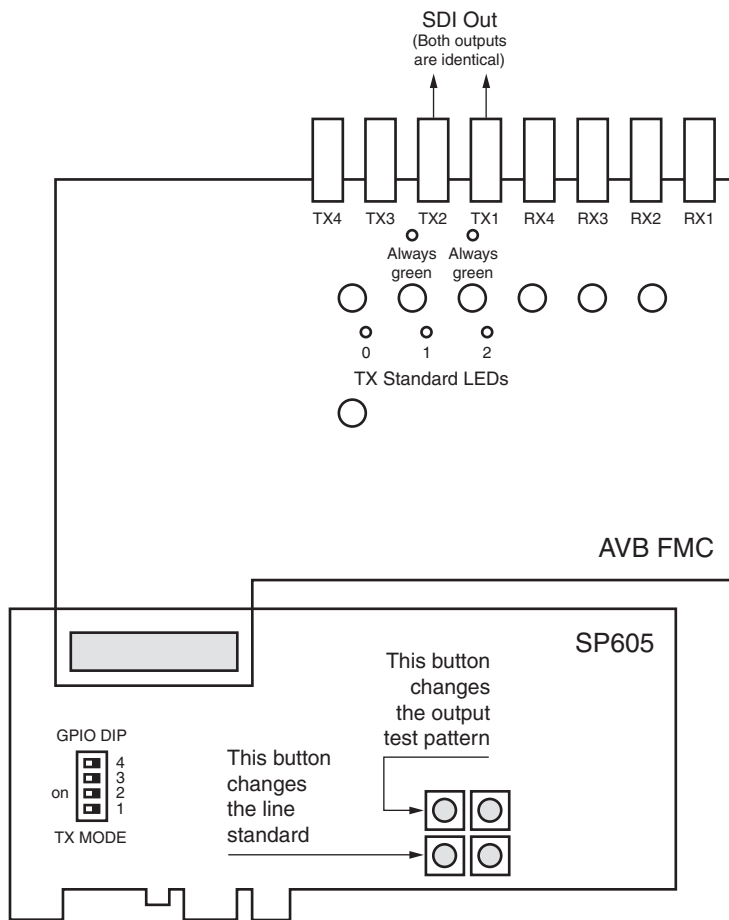

X1076\_20\_111510

Figure 20: Triple-Rate SDI Transmitter Demonstration

The TX mode is controlled by the GPIO DIP switches on the SP605 board. Switches 1 and 2 determine the mode, as identified in Table 15. Switch 3 controls the reference clock frequency, and therefore the bit rate. Not all line standards have a valid /M mode, so switch 3 is ignored for line standards that have only one valid bit rate. Switch 4 should always be OFF.

Table 15: Transmitter Modes

| Switch 1 | Switch 2 | Mode    |
|----------|----------|---------|
| OFF      | OFF      | HD-SDI  |
| OFF      | ON       | SD-SDI  |
| ON       | OFF      | 3G-SDI  |
| ON       | ON       | Invalid |

The line standard is indicated by the three TX standard LEDs that illuminate orange. The bit 0 LED is near the AESTX1 connector, the bit 1 LED is near SYNC IN, and the bit 2 LED is near the AES3 RX2 connector. The line standard can be incremented using the line standard button (SW5). The standards are identified in Table 16.

Table 16: Transmitter Line Standards

| Mode   | Standard Value | LED 2 | LED 1 | LED 0 | Switch 3 (Bit Rate) | Line Standard   |
|--------|----------------|-------|-------|-------|---------------------|-----------------|
| SD-SDI | 0              | OFF   | OFF   | OFF   | x                   | NTSC            |
|        | 1              | OFF   | OFF   | ON    | x                   | PAL             |
| HD-SDI | 0              | OFF   | OFF   | OFF   | x                   | 720p 50 Hz      |
|        |                | OFF   | OFF   | ON    | OFF                 | 1080sF 24 Hz    |
|        | 1              | OFF   | OFF   | ON    | ON                  | 1080sF 23.98 Hz |
|        |                | OFF   | ON    | OFF   | ON                  | 1080i 30 Hz     |
|        | 2              | OFF   | ON    | OFF   | ON                  | 1080i 29.97 Hz  |
|        |                | OFF   | ON    | ON    | x                   | 1080i 25 Hz     |
|        | 3              | ON    | OFF   | OFF   | OFF                 | 1080p 30 Hz     |
|        |                | ON    | OFF   | OFF   | ON                  | 1080p 29.97 Hz  |
|        | 4              | ON    | OFF   | ON    | x                   | 1080p 25 Hz     |
|        | 5              | ON    | ON    | OFF   | OFF                 | 1080p 24 Hz     |
|        |                | ON    | ON    | OFF   | ON                  | 1080p 23.98 Hz  |
|        | 6              | ON    | ON    | ON    | OFF                 | 720p 60 Hz      |
| ON     |                | ON    | ON    | ON    | 720p 59.94 Hz       |                 |
| 3G-SDI | 4              | ON    | OFF   | OFF   | OFF                 | 1080p 60 Hz     |
|        |                | ON    | OFF   | OFF   | ON                  | 1080p 59.94 Hz  |
|        | 5              | ON    | OFF   | ON    | x                   | 1080p 50 Hz     |

There are two or three test patterns available depending on mode. In each case, one of these is the pathological pattern. The test pattern can be changed via the test pattern button (SW4).

## Triple-Rate Receiver Demonstration

The receiver demonstrates the capability to receive in SD-SDI, HD-SDI, and 3G-SDI modes, determine the mode, and decode and lock onto the correct mode and line standard. For 3G-SDI mode, only Level A format is supported in this demonstration. For SD-SDI mode, EDH

packets are analyzed and errors are indicated. For HD-SDI and 3G-SDI modes, CRC is checked, and errors are indicated.

The basic elements of the hardware for the triple-rate SDI transmitter demonstration are shown in [Figure 21](#). SDI is input at the SDI RX1 port on the FMC card. The adjacent LED illuminates green if the carrier detect from associated cable equalizer device on the card is active. If no carrier is detected, the LED is red.

The GPIO LEDs at the bottom of the SP605 board serve as the TX status LEDs ([Figure 21](#)). Their functions are described in [Table 17](#).

**Table 17: Transmitter Status LEDs**

| LED                   | Name     | Description  |
|-----------------------|----------|--|
| 0 (DS3)               | Rate     | Illuminates when the received line standard is /1.001 rate.  |
| 1 and 2 (DS4 and DS5) | Mode     | SDI Mode. Refer to <a href="#">Table 18</a> for mode selection.  |
| 3 (DS6)               | rx error | Receiver error bit. For SD-SDI mode, this is an EDH error. For HD-SDI and 3G-SDI, it is a CRC error. This LED remains illuminated until cleared with the error clear pushbutton SW7 (see <a href="#">Figure 21</a> for location of SW7). |
| 4 (DS7)               | Locked   | Illuminates when the SDI mode and rate are successfully detected and locked.   |

**Table 18: Receiver Modes**

| LED 2 | LED 1 | Mode    |
|-------|-------|---------|
| OFF   | OFF   | HD-SDI  |
| OFF   | ON    | SD-SDI  |
| ON    | OFF   | 3G-SDI  |
| ON    | ON    | Invalid |

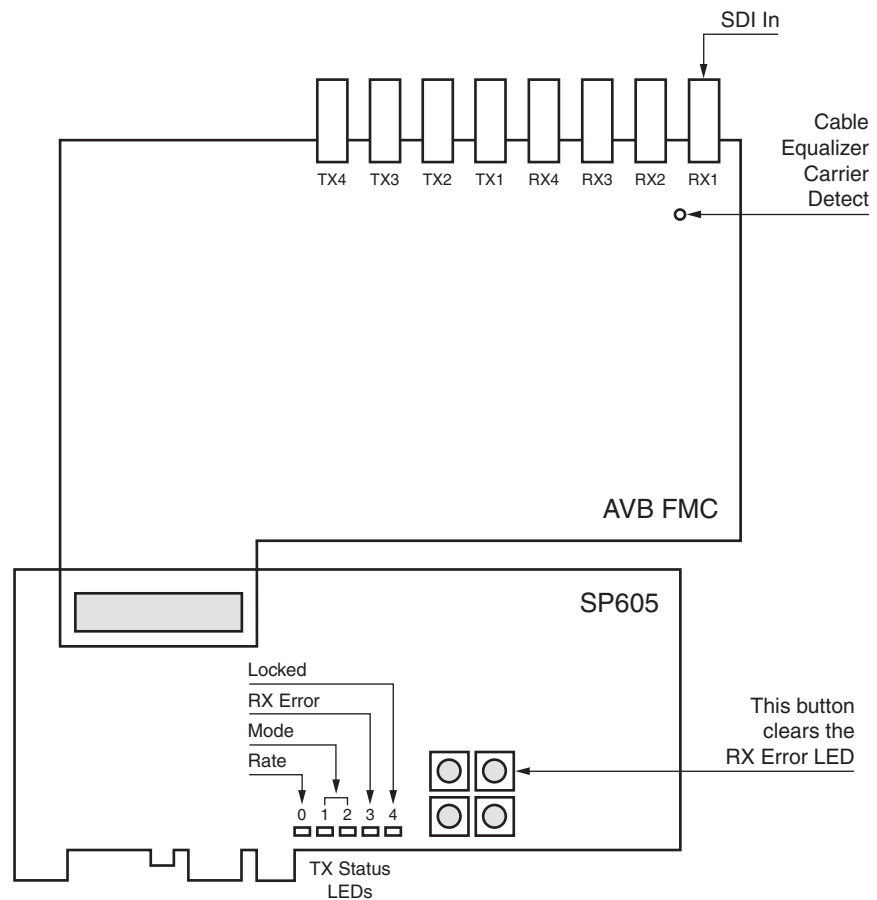

X1076\_21\_090310

*Figure 21: Triple-Rate SDI Receiver Demonstration*

Much of the data and status information from the receiver is only observable using the ChipScope tool. A project for the ChipScope Pro software v12.2 is included with the reference design. It contains a VIO module and an ILA module. The VIO module provides status information about the receiver and the video format being received. The ILA module shows the video and timing information output by the receiver.

## Appendix B: Triple-Rate SDI Genlock Pass-Through Demonstration

The SP605 board in combination with the FPGA broadcast mezzanine card (FMC card) and a clock module can be used to demonstrate the triple-rate RX and TX capabilities of Spartan-6 devices in a pass-through configuration and in a genlock mode.

Only a genlocked demonstration is possible for pass-through on the SP605 board with the FMC card. A non-genlocked pass-through demonstration requires a free-running clock for the SDI receiver, and also a recovered clock for the SDI transmitter (see [Figure 26, page 59](#)). However, it is not possible to use two clocks on the SP605 board through the FMC because the FMC connector of the SP605 board is wired to a single GTP transceiver on the Spartan-6 FPGA. Each transceiver has a single clock input (See [Figure 22](#)).

Therefore, although non-genlocked pass-through SDI is supported by the Spartan-6 FPGA, the fact that it requires separate transceivers for the RX and TX precludes it from being demonstrated on the SP605/FMC card demonstration platform. Thus, a genlocked demonstration is included with the reference design.

The demonstration design described in this appendix incorporates both the transmitter and receiver designs for triple-rate SDI on Spartan-6 devices connected in a pass-through configuration and demonstrates the basic functionality of both. The demonstration runs on an SP605 card connected to an FMC card with a clock module card (Clock Module L) mounted on the FMC card.

The FMC connector on the SP605 board contains connections to a single GTP transceiver on the Spartan-6 FPGA. To use this single transceiver with a single shared clock to both transmitter and receiver, the demonstration utilizes a genlock configuration in which a reference sync is used to generate the reference clock to the GTP transceiver.

### Hardware Configuration

To use the single transceiver connected to the FMC connector, this demonstration uses a single reference clock that is synchronized to the incoming video via genlock. Thus, this clock is present even when the SDI source is disconnected. This prevents lock-up that would otherwise be possible if one attempted to use the incoming SDI as the timing source to recover a clock from itself.

[Figure 22](#) is a simplified diagram of the pass-through demonstration. The video source and the SP605 board are both genlocked to a single sync source. The SDI stream is received by the GTP transceiver in the FPGA, converted to parallel data and decoded by the RX logic. The parallel data is passed to the TX logic where it is re-encoded for transmission and sent out through the TX portion of the GTP transceiver. The video out of the SP605 board is identical to the input stream but delayed.

This demonstration uses the genlock control HDL module to control genlock operation using the FMC card and the clock module mounted on it. This module is described in [Genlock Control Module, page 53](#).

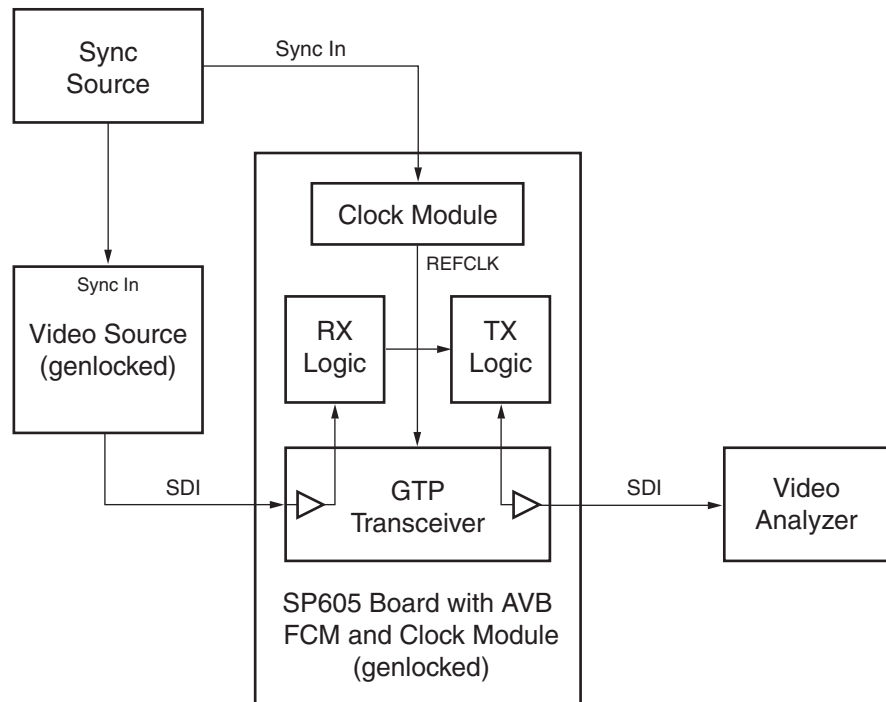

X1076\_22\_111710

Figure 22: **SP605 Configuration for Genlocked Pass-Through Demonstration**

Figure 23 shows how the `s6_sdi_rx_light_20b` module in the RX section is connected to the `triple_sdi_vpid_insert` module in the TX section. Mode and line standard information is extracted by the RX section to produce the correct clocks and to operate the TX section in the proper manner.

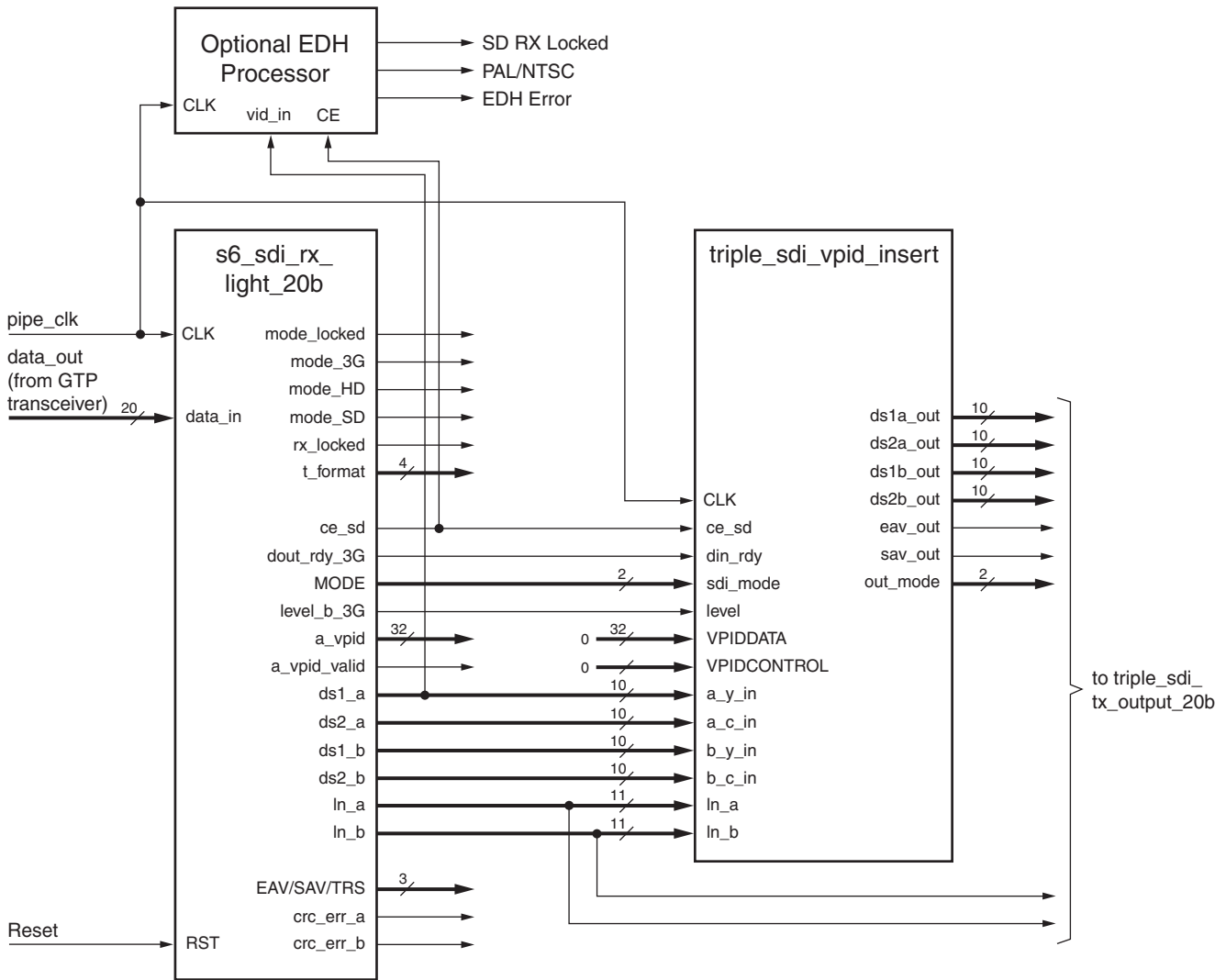

X1076\_23\_090310

Figure 23: RX to TX Connections

In HD-SDI mode and 3G-SDI mode, the pipeline logic in the RX and TX sections operates at the same pipeline clock rate with an operation occurring at every clock. In contrast, in SD-SDI mode, the RX pipeline clock runs at half the rate of the TX clock, and a clock enable is used to slow the timing of the pipeline relative to the clock, so that operations happen at the 270 MHz SD-SDI rate. The lower RX clock rate is necessary to accommodate the data recovery unit, and the higher TX clock rate is required because the data rate of the GTP output must be an integer multiple (11X) of the SD-SDI data rate (see [SD-SDI Transmitter Operation, page 23](#) for details). Also, the recovered clock enable from the RX section follows a 3/3/3/2 on a 74.25 MHz clock, whereas the TX modules require a clock enable cadence of 5/6/5/6 on a 148.5 MHz clock.

Figure 24 shows how data is passed from the RX domain to the TX domain, and shows the relationship of the various timing signals. A small state machine is used to create the TX clock enable with 5/6/5/6 cadence, and a shortened pulse width, but locked to the RX clock enable. Figure 24 shows the states of this state machine and the sequence in the RX clock enable that triggers a reset of this state machine.

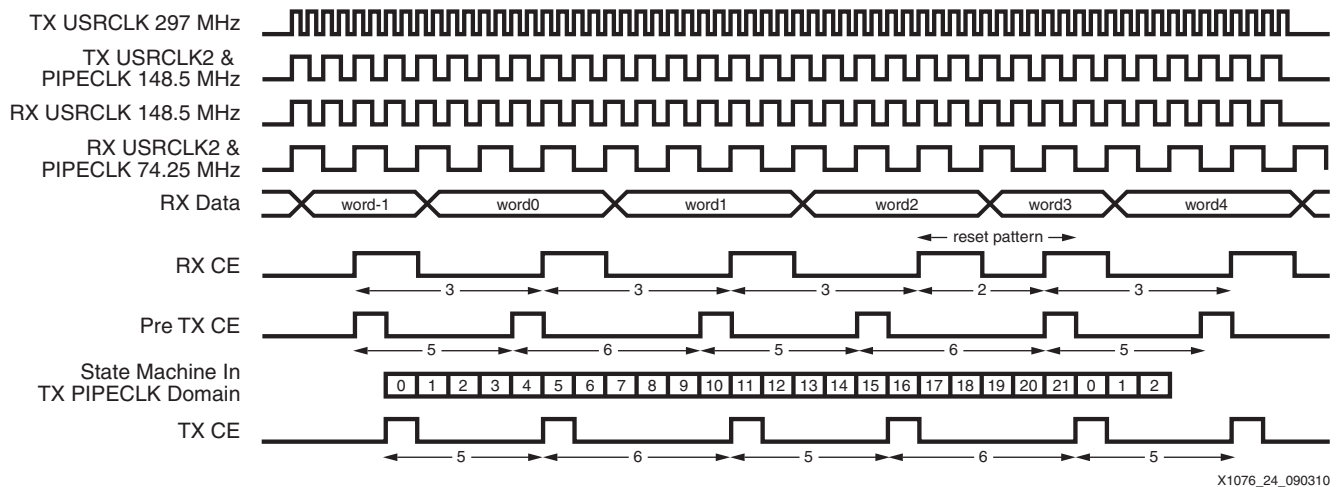

Figure 24: RX to TX Timing of Data and Clock Enables

## Genlock Control Module

The genlock control module, `genlock_control`, controls multiple Si5324 digital phase-locked loops (PLLs) to implement a genlocked system. The module handles switching the system in and out of genlock mode. When not in genlock mode, the system runs from the local 27 MHz crystal oscillator on the broadcast FMC mezzanine card.

The module is designed to work with either two or three Si5324 devices. The main Si5324 device, generally the Si5324 that is on the FMC mezzanine card itself, as opposed to the ones on the clock modules, is used to create a 27 MHz clock from the external horizontal sync signal when running in genlocked mode. In non-genlocked mode, this Si5324 passes the 27 MHz signal from the local crystal oscillator straight through, running in a 27 MHz in / 27 MHz out mode. The 27 MHz signal created by the main Si5324 is used as the reference clock to the other Si5324 devices that synthesize the GTP transceiver reference clocks from the 27 MHz input.

### Si5324 Control

The main Si5324 device must have both its input clock source and its input frequency select selection changed as the system is switched between genlock and non-genlock modes. The secondary Si5324 devices are, essentially, statically programmed to always take in 27 MHz and output the proper GTP transceiver reference clock frequencies.

The secondary Si5324 devices, those fed from the main Si5324 device, can have very long lock times (on the order of about one minute), if they are not controlled properly. When the 27 MHz signal from the main Si5324 device changes as the system is switched between genlock and non-genlock modes, the secondary Si5324 devices must first be placed into digital holdover mode (DHOLD) before the main Si5324 device is reprogrammed, otherwise they will often exhibit this long lock time behavior.

Also, the secondary Si5324 devices must be controlled carefully immediately after FPGA configuration. They must be controlled in such a way that they perform an internal calibration (ICAL) cycle after the main Si5324 has locked and is outputting a valid and stable 27 MHz signal. On the broadcast FMC card, the only way to force a Si5324 ICAL cycle is to change the frequency synthesis scheme. The application must be written so that the Si5324 devices are held in a dummy mode by programming their frequency selection to some mode other than the actual intended operating mode until the main Si5324 device has locked. After the main Si5324 device locks, the application must switch the secondary Si5324 devices into their intended frequency synthesis mode, converting 27 MHz to the GTP transceiver reference clock frequencies. The `genlock_control` module provides a signal that indicates when the main

Si5324 device has reached lock for the very first time after FPGA configuration specifically for this purpose.

The initial startup after FPGA configuration is carefully controlled by the `genlock_control` module. The module initially sets the main Si5324 device to lock to the 27 MHz local crystal oscillator, even if genlock mode is selected. After the main Si5324 device is locked to the 27 MHz reference, the secondary Si5324 devices are programmed. These devices do an internal calibration, locking to the 27 MHz clock from the main Si5324 devices. After all Si5324 devices have locked, the module allows the system to switch to genlock mode if genlock mode has been selected. This ensures that all devices are initially locked and provides a clean transition to genlock mode.

There is a case that is not completely handled by the `genlock_control` module. If the system is operating in genlock mode and the frequency of the external horizontal sync changes, the control module cannot place the secondary Si5324 devices into digital hold mode before the main Si5324 device loses lock. Therefore, this case often experiences long lock times for the secondary Si5324 devices. The secondary Si5324 devices do recover and the system returns to normal operation, but it can take up to a minute for this to occur.

## Inputs and Outputs

The ports of the `genlock_control` module are described in [Table 19](#).

**Table 19: Ports of the `genlock_control` Module**

| Port Name       | I/O | Width | Description  |
|-----------------|-----|-------|--|
| clk             | In  | 1     | This clock input must be driven by the same clock that controls the clk inputs of the <code>main_avb_control</code> and <code>cm_avb_control</code> modules. This is typically the 27 MHz clock signal from the crystal oscillator on the broadcast FMC card (which is not the same signal as the 27 MHz output of the main Si5324). |
| hsync_in        | In  | 1     | This must be driven by the horizontal signal from the FMC mezzanine card that comes from the LMH1981 sync separator. The horizontal sync signal enters the carrier board on the LA30_P signal (H34).   |
| genlock_enable  | In  | 1     | This input port determines whether the system runs in genlock mode (1) or non-genlock mode (0). It is treated as an asynchronous input and synchronized to clk before being used internally.   |
| default_code    | In  | 5     | This port supplies the non-genlock input frequency select value for the main Si5324 device. When running in non-genlock mode, the <code>in_freq_sel</code> output port of this module is set equal to the <code>default_code</code> value. Typically, this is set to <code>5'b10111</code> to select a 27 MHz input frequency.       |
| default_bw_sel  | In  | 4     | This port supplies the value that is written into the bandwidth select registers of the main Si5324 device when the system is running in non-genlock mode. In genlock mode, the bandwidth is specified by the <code>GENLOCK_SI5324_BW_SEL</code> parameter.  |
| sync_video_fmt  | In  | 11    | This input port must be connected to the <code>sync_video_fmt</code> output port of the <code>main_avb_control</code> module.  |
| sync_frame_rate | In  | 3     | This input port must be connected to the <code>sync_frame_rate</code> output port of the <code>main_avb_control</code> module.   |
| Si5324_LOL_0    | In  | 1     | This input port should be connected to the loss of lock (LOL) output of the main Si5324 device. This is usually the <code>Si5324_LOL</code> output port of the <code>main_avb_control</code> module.   |

Table 19: Ports of the genlock\_control Module (Cont'd)

| Port Name      | I/O | Width | Description   |
|----------------|-----|-------|---|
| Si5324_LOL_1   | In  | 1     | This input port should be connected to the LOL output of one of the secondary Si5324 devices. If there is only one secondary Si5324 device, its LOL signal should be connected here. This input is normally connected to one of the Si53234_x_LOL outputs of the cm_avb_control module.   |
| Si5324_LOL_2   | In  | 1     | This input port should be connected to the LOL output of one of the secondary Si5324 devices. If there is only one secondary Si5324 device used by the genlock application, this input should be wired Low. This input is normally connected to one of the Si53234_x_LOL outputs of the cm_avb_control module.  |
| Si5324_clk_sel | Out | 1     | This port must control the input clock selection of the main Si5324 device. When this input is Low, the 27 MHz local crystal oscillator must be selected as the main Si5324 input clock. When this input is High, the horizontal sync signal from the sync separator must be selected. For most applications, both bits of the Si5324_clkin_sel port of the main_avb_control module should be driven Low when this output is Low and both driven High when this output is High.   |
| in_freq_sel    | Out | 5     | This port must control the input frequency selection of the main Si5324 device. Normally, this port is connected to the Si5324_in_fsel input port of the main_avb_control module.   |
| Si5324_bw_sel  | Out | 4     | This port must control the bandwidth selection of the main Si5324 device. Normally, this port is connected to the Si5324_bw_sel input port of the main_avb_control module.  |
| Si5324_locked  | Out | 1     | This output is Low after FPGA configuration and remains Low until the main Si5324 has locked for the very first time. This output is used to control the input frequency selects of the secondary Si5324 devices so that they switch to their final programming mode only after the main Si5324 device is locked for the first time. Thus, when this output is Low, the application must apply some valid input frequency select value, other than the actual intended input frequency select value, to the input frequency select input ports of the secondary Si5324 devices. When this output switches to High, the final input frequency select code (usually 5'b10111 for 27 MHz) must be applied to the input frequency select ports (usually the Si5324_x_in_fsel ports of the cm_avb_control module). |
| sync_missing   | Out | 1     | This output is High if the horizontal sync input signal stops.  |
| sync_invalid   | Out | 1     | This output is High if the sync_video_fmt and sync_frame_rate inputs do not match a supported video standard.   |
| local_lock     | Out | 1     | This output is High when the system is locked to the local 27 MHz crystal oscillator. This output is only asserted after all Si5324 devices have achieved lock.   |

Table 19: Ports of the `genlock_control` Module (Cont'd)

| Port Name                 | I/O | Width | Description  |
|---------------------------|-----|-------|--|
| <code>genlock</code>      | Out | 1     | This output is High when the system is locked to the external sync signal. This output is only asserted after all Si5324 devices have achieved lock.   |
| <code>Si5324_DHOLD</code> | Out | 1     | This output controls the digital holdover mode of the secondary Si5324 devices. This is usually wired to the <code>Si5324_x_DHOLD</code> inputs of the <code>cm_avb_control</code> for all Si5324 devices that are driven by the 27 MHz clock from the main Si5324 device. |

### Usage Description

The Spartan-6 FPGA genlock pass-through demonstration uses three Si5324 devices – the main Si5324 on the broadcast FMC mezzanine card and two Si5324 devices (the B and C devices) on the “L” clock module. The Si5324 devices are configured as shown in [Figure 25](#). The main Si5324 device gets either the 27 MHz local crystal oscillator or the horizontal sync signal. Both of these inputs are multiplexed into the CKIN2 input of the Si5324 device by the Spartan-3A FPGA under the control of the `Si5324_ckin_sel` port of the `main_avb_control` module.

The 27 MHz output of the main Si5324 device is connected to the CKIN1 port of Si5324 C by routing it through clock crossbar 1. This 27 MHz signal is also routed to CKIN2 port of Si5324 B by wrapping the 27 MHz signal through the ML605 carrier board and back out to the clock module on the broadcast FMC mezzanine card.

Si5324 B on the clock module is programmed to generate a 148.5 MHz reference clock. Si5324 C on the clock module is programmed to generate a 148.35 MHz reference clock. These two clocks go into the crossbar switch, XBAR1. Based on the line standard of the incoming video, one of these two clocks is selected to be the GTP reference clock, `GBTCLK0_M2C`, on the SP605 board. Because the reference clock to the GTP transceiver changes due to the received SDI data, the entire GTP transceiver must be reset each time the reference clock selection changes.

The output frequency select ports of the `cm_avb_control` module for these two Si5324 devices (on clock module L) are hard wired to generate 148.5 MHz and 148.35 MHz output frequencies from a 27 MHz input. However, the input frequency select for these two Si5324 devices is multiplexed. This multiplexer is controlled by the `Si5324_locked` port of the `genlock_control` module. When `Si5324_locked` is Low as the device comes out of configuration, the multiplexor drives a value of `5'b00000` into the input frequency select ports for the two Si5324 devices. After the main Si5324 device is locked and `Si5324_locked` goes High, a value of `5'b10111` (selecting 27 MHz as the input frequency) is driven to the input frequency select ports of the two Si5324 devices. This switch forces these two Si5324 devices to run an ICAL cycle and calibrate themselves to the 27 MHz input clock from the main Si5324 device. This is essential to ensure that these two Si5324 devices lock.

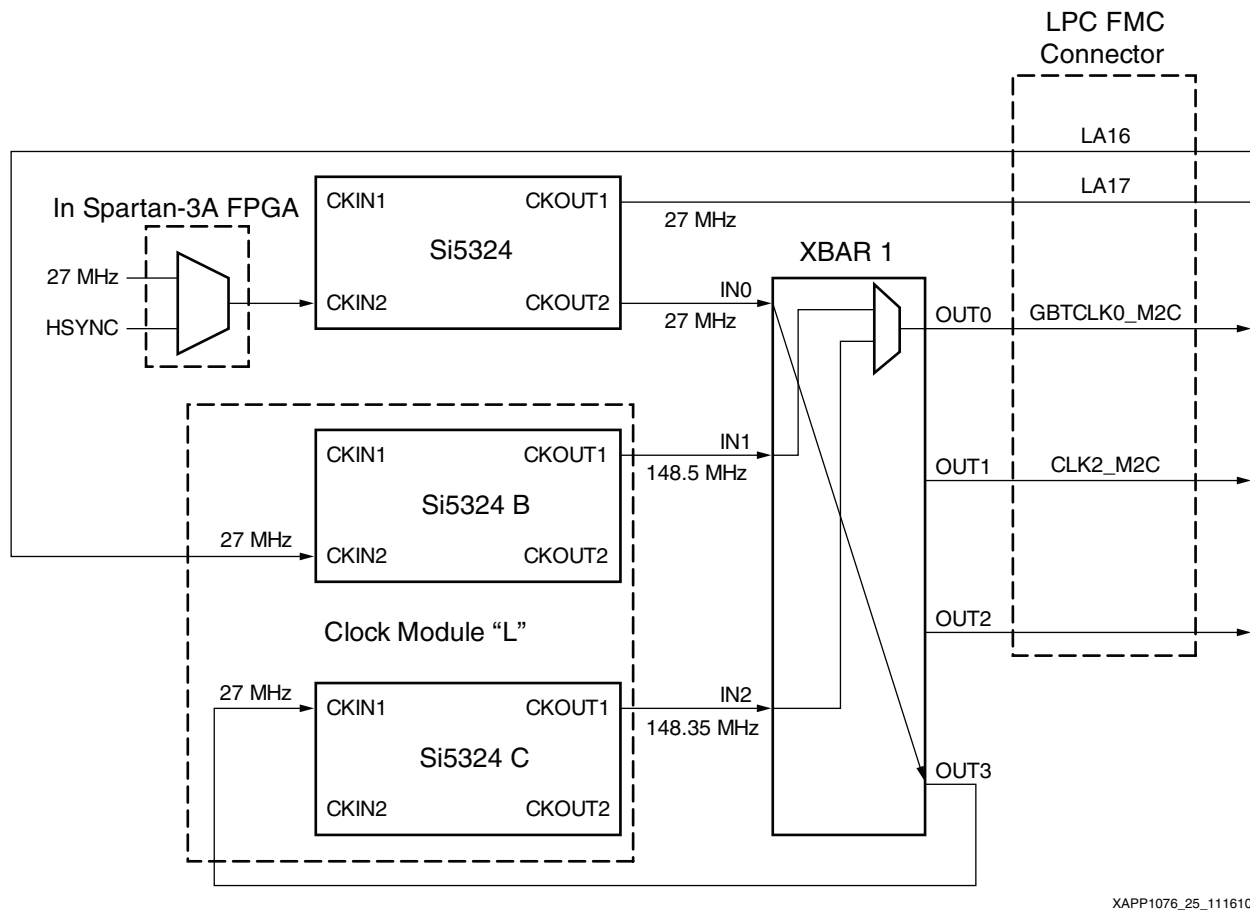

XAPP1076\_25\_111610

**Figure 25: Clocking for Spartan-6 FPGA Genlock Pass-Through Demonstration**

The LOL signals from the secondary Si5324 devices are also connected to the RX and TX reset inputs of the GTP transceiver. GTPRXRESET and GTPTXRESET reset the entire GTP RX and TX, respectively, including the PMA PLLs. The PMA PLLs must be reset whenever the input reference clocks change or are unstable. Thus, using the LOL signals from the Si5324 devices ensures that the PMA PLLs stay in reset until after the reference clocks have stabilized. The GTPRXRESET inputs are only connected to the LOL of Si5324 B because the receivers only use the 148.5 MHz reference clock generated by this Si5324 device. The transmitters, on the other hand, can be driven by either Si5324 device. Thus, the GTPTXRESET inputs are connected to the OR of LOL signals from Si5324 B and Si5324 C.

The three Si5324 devices on the clock module have asserted Low reset inputs that are controlled by pins on the FMC connector. Because these resets are asserted Low, the application must drive these reset inputs High using the FPGA on the carrier board. The three Si5324 resets for clock module “L” are shown in [Table 20](#).

**Table 20: Clock Module L Si5324 Reset Signals**

| Si5324 Device | Reset FMC Pin |
|---------------|---------------|
| Si53234 A     | D17 (LA13_P)  |
| Si5324 B      | D26 (LA26_P)  |
| Si5324 C      | G36 (LA33_P)  |

It is also possible to build a genlock demonstration with two Si5324 devices, rather than three. The main Si5324 device still takes in either 27 MHz for local lock or HSYNC for genlock and generates 27 MHz. This 27 MHz output is fed into one other Si5324 device that is programmed

to generate either 148.5 MHz or 148.35 MHz, as required. To dynamically switch the TX bit rate, this secondary Si5324 device must be reprogrammed. This makes the process somewhat slower than when using three Si5324 devices.

### State Diagram

[Figure 26](#) shows the state diagram of the FSM that controls the `genlock_control` module's operation.

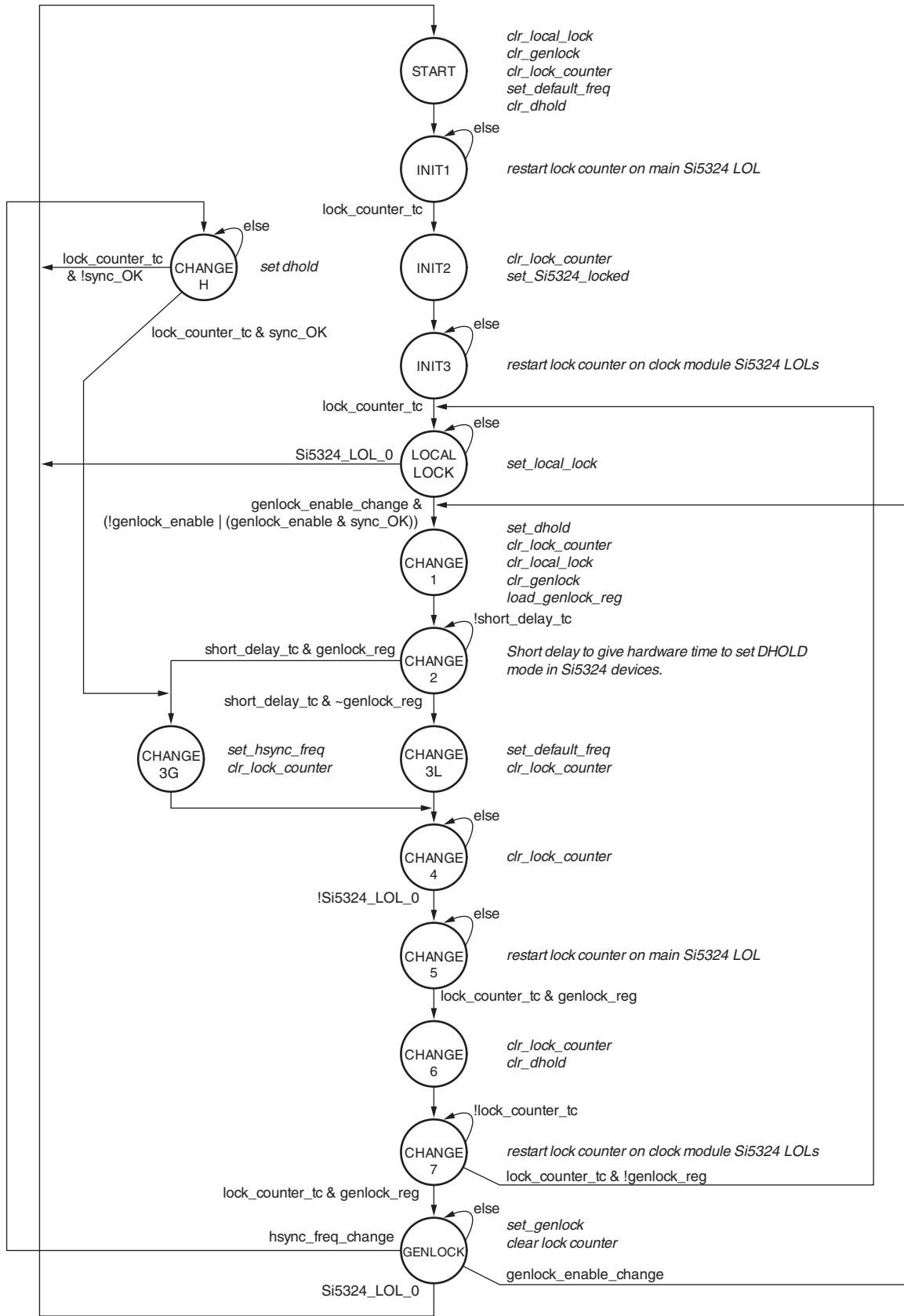

XAPP1076\_26\_111510

Figure 26: Genlock Control State Diagram

## Recommended Configurations

The single transceiver used in this demonstration (due to the limitation of a single GTP transceiver on the SP605 FMC connector) is not recommended for a pass-through configuration. A preferred configuration is to use separate transceivers for RX and TX so that the RX can have an independent free-running clock, as shown in [Figure 27](#). The TX clock should be derived from the RX recovered clock to ensure that the TX output is synchronized with the incoming video stream.

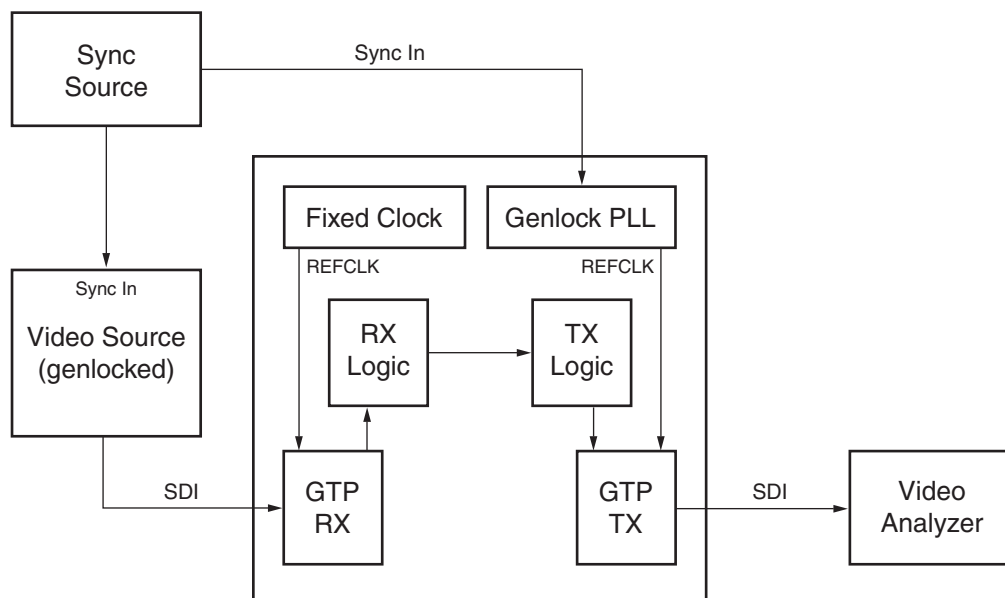

X1076\_27\_111510

Figure 27: Recommended Configuration for Genlocked Pass-Through Operation

In the general case, pass-through operation does not require genlock. The GTP RX can use a fixed rate reference clock to recover a clock based on the incoming data. This clock can be passed through a clock cleaner chip external to the FPGA to reduce the jitter and provide a reference clock suitable for the GTP TX. In this way, the TX is locked to the incoming SDI data, but the incoming data need not be genlocked to any external timing source. This is shown in [Figure 28](#).

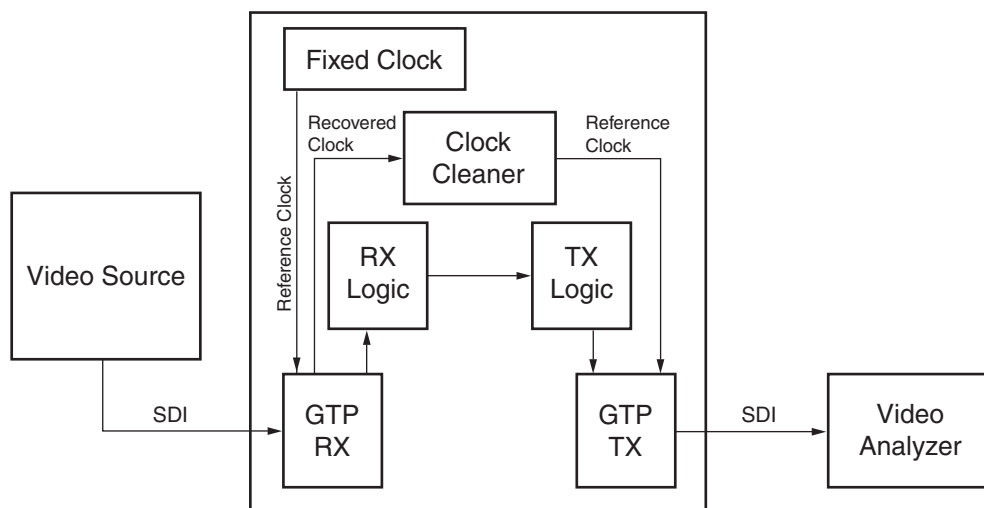

X1076\_28\_111610

Figure 28: Recommended Configuration for Non-Genlocked, Pass-Through Operation

## Demonstration Setup

Figure 29 shows the basic elements of the SP605 hardware. The FMC card is connected to the SP605 board via the LPC FMC connector with the FMC card on top, as shown. The FMC card receives all of its power and control from the SP605 board. For this demonstration, a clock module must be installed in the “Clock Module L” location.

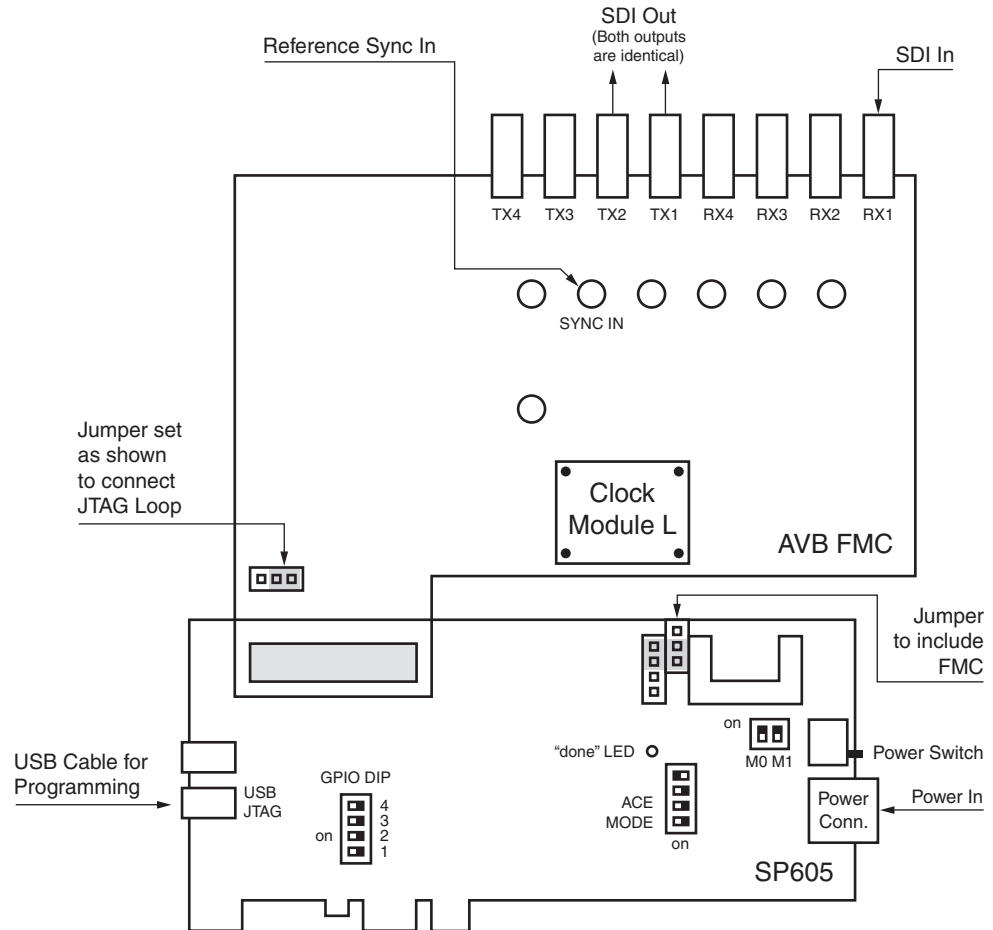

X1076\_29\_111510

Figure 29: Triple-Rate SDI Pass-Through Demonstration Setup

Two jumpers must be set up properly to include the FMC card in the JTAG shift loop. One is on the FMC JTAG jumper (J19) on the SP605 card, and is set to include the FMC connector in the loop. The other is the JTAG CONFIG jumper (J21) on the FMC card and is set to exclude the expansion FMC connector from the loop.

There are two sets of DIP switches pertain to loading the Spartan-6 FPGA on the SP605 board:

1. Mode switches (SW1) for M0 and M1. These should both be set to ON.
2. The ACE MODE (S1) and program switches. These pertain to programming the FPGA from a CompactFlash card. Normally, switches 1, 2, and 3 are OFF, and switch 4 is ON.

A third set of DIP switches, the GPIO DIP switches, are not used in this demonstration.

The power cable must be plugged into the power connector and a USB cable is plugged into the USB JTAG port to program the FPGA via JTAG.

The reference clock is received through the top-mounted BNC labeled “SYNC IN”.

Video inputs and outputs are at the top of the FMC card. There are two identical transmitter outputs and one receiver input.

The Spartan-3 FPGA on the FMC card must be preprogrammed for audio and video demonstrations. Refer to *FPGA Broadcast Mezzanine Card User Guide* [Ref 5] for more information on the FMC card.

The Spartan-6 FPGA on the SP605 board can be programmed with the demo bit file via the USB JTAG port using the ChipScope software. The “done” bit LED indicates programming status. The demo bit file enables both the receiver and transmitter demonstrations.

## Demonstration Operation

The pass-through demonstration shows the ability to receive SD-SDI, HD-SDI, and 3G-SDI, determine the mode, decode a lock on to the correct mode and line standard, and retransmit the data as it was received. For 3G, Level A and Level B are supported in this demonstration. As data is received, errors are checked. For SD-SDI, EDH packets are analyzed and errors indicated. For HD-SDI and 3G-SDI, CRC is checked, and errors are indicated.

**Figure 30** shows elements of the configuration pertinent to the triple-rate pass-through demonstration. The reference sync used for clock creation is input to the SYNC\_IN port. SDI is input at the SDI RX1 port on the FMC card. The adjacent LED lights up green if the carrier detect from associated cable equalizer chip on the card is active. If no carrier is detected, the LED is red.

The reference sync is input to the SYNC IN connector, which has an adjacent LED that is normally green, but turns red if a problem with the sync is detected by the Si5324 device to which it is connected. The reference sync must be synchronous with the SDI input video source.

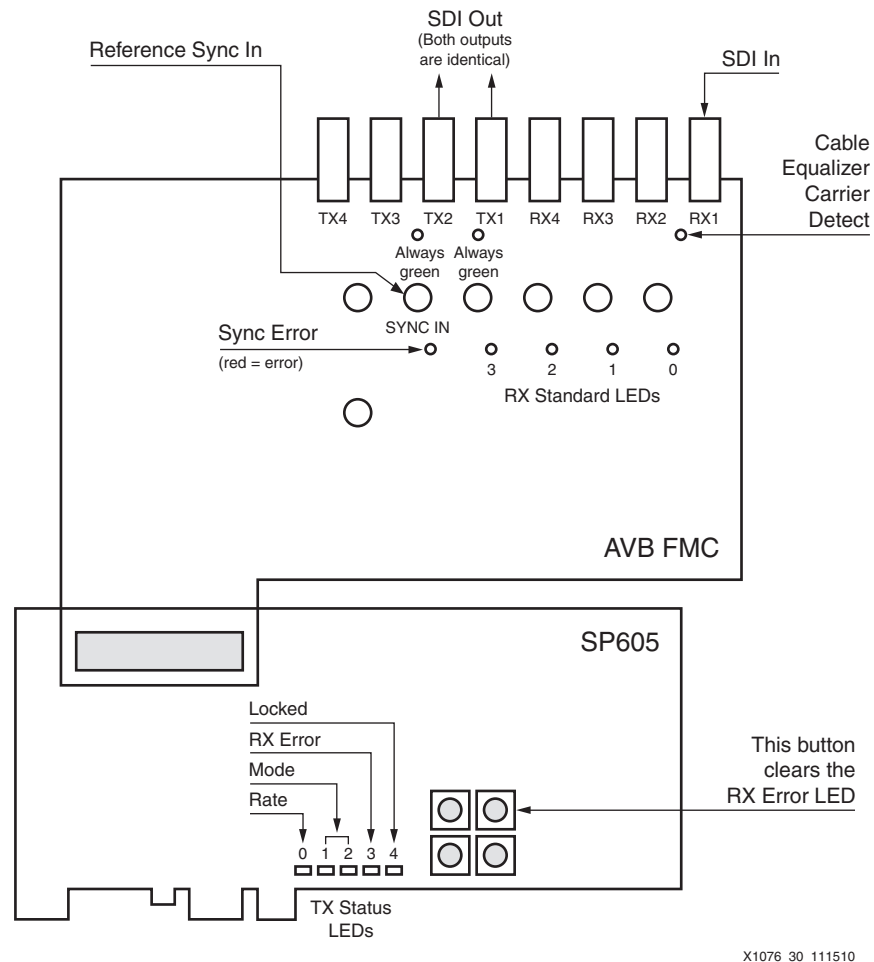

Figure 30: Triple-Rate SDI Genlock Pass-Through Demonstration

The GPIO LEDs at the bottom of the SP605 board serve as the status LEDs as shown in Figure 30 and described in Table 21 through Table 23. Table 21 lists the function of the status LEDs on the SP605 board. Table 22 lists the coding of the mode LEDs. Table 23 shows the coding of the line standard LEDs for line standards supported by this demonstration. Refer to Figure 29 for the location of these LEDs. The RX error LED is persistent and stays lit even after the error has gone away. The pushbutton indicated (SW7) clears the LED until the next error is detected.

There are four LEDs called the *RX Standard LEDs* near the topside BNC connectors that identify the line standard recognized by the RX section when it is locked. There are four LEDs called the *Line Standard LEDs* that identify the line standard recognized by the RX section when it is locked.

Table 21: TX Status LEDs

| LED                   | Name | Meaning   |
|-----------------------|------|---|
| 0 (DS3)               | rate | ON: Received line standard is /1.001 rate<br>OFF: Received line standard is /1 rate |
| 1 and 2 (DS4 and DS5) | mode | SDI Mode (see Table 22).  |

Table 21: TX Status LEDs (Cont'd)

| LED     | Name     | Meaning   |
|---------|----------|---|
| 3 (DS6) | rx error | Receiver error bit. For SD-SDI mode, this is an EDH error. For HD-SDI and 3G-SDI modes, it is a CRC error. This LED is persistent, and can be cleared with the error clear button (see <a href="#">Figure 30</a> ). |
| 4 (DS7) | locked   | Indicates that the line standard detector is locked to the incoming video.<br>ON: Locked<br>OFF: Not locked   |

Table 22: Receiver Mode LEDs

| LED2 | LED1 | Mode    |
|------|------|---------|
| OFF  | OFF  | HD-SDI  |
| OFF  | ON   | SD-SDI  |
| ON   | OFF  | 3G-SDI  |
| ON   | ON   | Invalid |

Four LEDs called the *Line Standard LED* that identify the line standard recognized by the RX section when it is locked. [Table 23](#) shows the meaning of these LEDs in HD-SDI and 3G-SDI modes. These LEDs are always OFF in SD-SDI mode.

Table 23: Line Standards

| Mode           | STD # | LED 3 | LED 2 | LED 1 | LED 0 | LED DS3 (Bit Rate) | Line Standard                     |
|----------------|-------|-------|-------|-------|-------|--------------------|-----------------------------------|
| HD-SDI         | 0     | OFF   | OFF   | OFF   | OFF   | OFF                | 1035i 30 Hz                       |
|                |       | OFF   | OFF   | OFF   | OFF   | ON                 | 1035i 29.97 Hz                    |
|                | 2     | OFF   | OFF   | ON    | OFF   | OFF                | 1080i 30 Hz or 1080sF 30 Hz       |
|                |       | OFF   | OFF   | ON    | OFF   | ON                 | 1080i 29.97 Hz or 1080sF 29.97 Hz |
|                | 3     | OFF   | OFF   | ON    | ON    | OFF                | 1080i 25 Hz or 1080sF 25 Hz       |
|                |       | OFF   | ON    | OFF   | OFF   | OFF                | 1080p 30 Hz                       |
|                | 4     | OFF   | ON    | OFF   | OFF   | ON                 | 1080p 29.97 Hz                    |
|                |       | OFF   | ON    | OFF   | ON    | OFF                | 1080p 25 Hz                       |
|                | 7     | OFF   | ON    | ON    | ON    | OFF                | 720p 60 Hz                        |
|                |       | OFF   | ON    | ON    | ON    | ON                 | 720p 59.94                        |
|                | 9     | ON    | OFF   | OFF   | ON    | OFF                | 720p 50 Hz                        |
|                | 10    | ON    | OFF   | ON    | OFF   | OFF                | 720p 30 Hz                        |
| ON             |       | OFF   | ON    | OFF   | ON    | 720p 29.97 Hz      |                                   |
| 11             | ON    | OFF   | ON    | ON    | OFF   | 720p 25 Hz         |                                   |
| 3G-SDI Level A | 13    | ON    | ON    | OFF   | ON    | OFF                | 1080p 60 Hz                       |
|                |       | ON    | ON    | OFF   | ON    | ON                 | 1080p 59.97 Hz                    |
|                | 14    | ON    | ON    | ON    | OFF   | OFF                | 1080p 50 Hz                       |
| <b>3G SDI</b>  |       |       |       |       |       |                    |                                   |

Table 23: Line Standards (Cont'd)

| Mode    | STD # | LED 3 | LED 2 | LED 1 | LED 0 | LED DS3 (Bit Rate) | Line Standard  |
|---------|-------|-------|-------|-------|-------|--------------------|----------------|
| Level B | 2     | OFF   | OFF   | ON    | OFF   | OFF                | 1080p 60 Hz    |
|         |       | OFF   | OFF   | ON    | OFF   | ON                 | 1080p 59.97 Hz |
|         | 3     | OFF   | OFF   | ON    | ON    | OFF                | 1080p 50 Hz    |

The output video is transmitted with the same data and timing as the received video. This demonstrates the capability to transmit SD-SDI, HD-SDI, and 3G-SDI. Both SDI TX1 and SDI TX1 connectors on the FMC card output identical SDI signals.

## Conclusion

The combination of the FPGA broadcast mezzanine card with the SP605 board is useful for demonstrating the capabilities of the triple-rate SDI reference designs. Using inputs and outputs provided by this hardware platform, the basic functionality of both the receiver and transmitter can be demonstrated using the demonstrations described in this document.

## Revision History

The following table shows the revision history for this document.

| Date     | Version | Description of Revisions |
|----------|---------|--------------------------|
| 12/15/10 | 1.0     | Initial Xilinx release.  |

## Notice of Disclaimer

Xilinx is disclosing this Application Note to you "AS-IS" with no warranty of any kind. This Application Note is one possible implementation of this feature, application, or standard, and is subject to change without further notice from Xilinx. You are responsible for obtaining any rights you may require in connection with your use or implementation of this Application Note. XILINX MAKES NO REPRESENTATIONS OR WARRANTIES, WHETHER EXPRESS OR IMPLIED, STATUTORY OR OTHERWISE, INCLUDING, WITHOUT LIMITATION, IMPLIED WARRANTIES OF MERCHANTABILITY, NONINFRINGEMENT, OR FITNESS FOR A PARTICULAR PURPOSE. IN NO EVENT WILL XILINX BE LIABLE FOR ANY LOSS OF DATA, LOST PROFITS, OR FOR ANY SPECIAL, INCIDENTAL, CONSEQUENTIAL, OR INDIRECT DAMAGES ARISING FROM YOUR USE OF THIS APPLICATION NOTE.