

XC4000 XLA Specification Information

Definition of Terms

In the following tables, some specifications may be designated as Advance or Preliminary. These terms are defined as follows:

Advance: Initial estimates based on simulation and/or extrapolation from other speed grades, devices, or families. Values are subject to change. Use as estimates, not for production.

Preliminary: Based on preliminary characterization. Further changes are not expected.

Unmarked: Specifications not identified as either Advance or Preliminary are to be considered final.

All specifications are subject to change without notice.

Additional Specifications

Except for pin-to-pin input and output parameters, the AC parameter delay specifications included in this document are derived from measuring internal test patterns. All specifications are representative of worst-case supply voltage and junction temperature conditions. The parameters included are common to popular designs and typical applications.

XC4000XLA D.C. Characteristic Guidelines

Absolute Maximum Ratings

Symbol	Description	Values	Units	
V_{CC}	Supply voltage relative to GND	-0.5 to 4.0	V	
V_{IN}	Input voltage relative to GND (Note 1)	-0.5 to 5.5	V	
V_{TS}	Voltage applied to 3-state output (Note 1)	-0.5 to 5.5	V	
V_{CCt}	Longest Supply Voltage Rise Time from 1 V to 3V	50	ms	
T_{STG}	Storage temperature (ambient)	-65 to +150	°C	
T_{SOL}	Maximum soldering temperature (10 s @ 1/16 in. = 1.5 mm)	+260	°C	
T_J	Junction temperature	Ceramic packages	+150	°C
		Plastic packages	+125	°C

- Notes: 1. Maximum DC overshoot or undershoot above V_{CC} or below GND must be limited to either 0.5 V or 10 mA, whichever is easier to achieve. During transitions, the device pins may undershoot to -2.0 V or overshoot to +7.0 V, provided this over- or undershoot lasts less than 10 ns and with the forcing current being limited to 200 mA.
2. Stresses beyond those listed under Absolute Maximum Ratings may cause permanent damage to the device. These are stress ratings only, and functional operation of the device at these or any other conditions beyond those listed under Operating Conditions is not implied. Exposure to Absolute Maximum Ratings conditions for extended periods of time may affect device reliability.

Recommended Operating Conditions

Symbol	Description	Min	Max	Units	
V_{CC}	Supply voltage relative to GND, $T_J = 0\text{ }^{\circ}\text{C}$ to +85°C	Commercial	3.0	3.6	V
	Supply voltage relative to GND, $T_J = -40\text{ }^{\circ}\text{C}$ to +100°C	Industrial	3.0	3.6	V
V_{IH}	High-level input voltage	50% of V_{CC}	5.5	V	
V_{IL}	Low-level input voltage	0	30% of V_{CC}	V	
T_{IN}	Input signal transition time		250	ns	

Note: At junction temperatures above those listed as Operating Conditions, all delay parameters increase by 0.35% per °C. Input and output measurement threshold is ~50% of V_{CC} .

DC Characteristics Over Recommended Operating Conditions

Symbol	Description		Min	Max	Units
V _{OH}	High-level output voltage @ I _{OH} = -4.0 mA, V _{CC} min (LVTTL)		2.4		V
	High-level output voltage @ I _{OH} = -500 μA, (LVCMOS)		90% V _{CC}		V
V _{OL}	Low-level output voltage @ I _{OL} = 24.0 mA, V _{CC} min (LVTTL) (Note 1)			0.4	V
	Low-level output voltage @ I _{OL} = 1500 μA, (LVCMOS)			10% V _{CC}	V
V _{DR}	Data Retention Supply Voltage (below which configuration data may be lost)		2.5		V
I _{CCO}	Quiescent FPGA supply current (Note 2)			10	mA
I _L	Input or output leakage current		-10	+10	μA
C _{IN}	Input capacitance (sample tested)	BGA, SBGA, PQ, HQ, MQ packages		10	pF
		PGA packages		16	pF
I _{RPU}	Pad pull-up (when selected) @ V _{in} = 0 V (sample tested)		0.02	0.25	mA
I _{RPD}	Pad pull-down (when selected) @ V _{in} = 3.6 V (sample tested)		0.02	0.15	mA
I _{RLL}	Horizontal Longline pull-up (when selected) @ logic Low		0.3	2.0	mA

Notes: 1. With up to 64 pins simultaneously sinking 24 mA

2. With no output current loads, no active input or Longline pull-up resistors, all I/O pins Tri-stated and floating

Power-On Power Supply Requirements

Xilinx FPGAs require a minimum rated power supply current capacity to insure proper initialization, and the power supply ramp rate does affect the current required. A fast ramp rate requires more current than a slow ramp rate. The slowest ramp rate is 50 ms with no specifications for a ramp rate faster than 2 ms.

Product	Description	Ramp Rate	
		Fast (120 μs)	Slow (50 ms)
XC4000XLA Family	Minimum required current supply	500 mA	500 mA

Notes: Fast condition is tested at factory only. Slow condition is tested at both wafer sort and factory.

All limits are based on VCC TRIP setting. Peak current is not measured. Devices are guaranteed to initialize properly with the minimum current listed above. A larger capacity power supply may result in a larger initialization current.

This specification applies to Commercial and Industrial grade products only.

XC4000 XLA Switching Characteristics

Testing of the switching parameters is modeled after testing methods specified by MIL-M-38510/605. All devices are 100% functionally tested. Internal timing parameters are derived from measuring internal test patterns. Listed below are representative values where one global clock input drives one vertical clock line in each accessible column, and where all accessible IOB and CLB flip-flops are clocked by the global clock net.

When fewer vertical clock lines are connected, the clock distribution is faster; when multiple clock lines per column are driven from the same global clock, the delay is longer. For more specific, more precise, and worst-case guaranteed data, reflecting the actual routing structure, use the values provided by the static timing analyzer (TRCE in the Xilinx Development System) and back-annotated to the simulation net list. These path delays, provided as a guideline, have been extracted from the static timing analyzer report. All timing parameters assume worst-case operating conditions (supply voltage and junction temperature). Values apply to all XC4000XLA devices and expressed in nanoseconds unless otherwise noted.

Delay Via Global Low Skew Clock Buffer to Clock

Description	Symbol	Speed Grade Device	All	-09	-08	-07	Units
			Min	Max	Max	Max	
Delay from pad through Global Low Skew (GLS) clock buffer to any clock input, K.	T _{GLS}	XC4013XLA	0.7	2.4	2.1	1.9	ns
		XC4020XLA	0.7	2.6	2.3	2.1	ns
		XC4028XLA	0.8	2.9	2.6	2.3	ns
		XC4036XLA	0.8	3.2	2.8	2.5	ns
		XC4044XLA	0.9	3.6	3.1	2.8	ns
		XC4052XLA	1.0	3.9	3.4	3.1	ns
		XC4062XLA	1.1	4.2	3.7	3.3	ns
		XC4085XLA	1.2	5.0	4.4	3.9	ns
Preliminary							

6

Delay Via FastCLK Buffer to IOB Clock

Description	Symbol	Speed Grade Device	All	-09	-08	-07	Units
			Min	Max	Max	Max	
Delay from pad through FastCLK buffer to any IOB clock input.	T _{FCLK}	XC4013XLA	0.4	1.5	1.3	1.1	ns
		XC4020XLA	0.5	1.5	1.3	1.2	ns
		XC4028XLA	0.5	1.6	1.4	1.3	ns
		XC4036XLA	0.5	1.7	1.5	1.4	ns
		XC4044XLA	0.5	1.8	1.6	1.4	ns
		XC4052XLA	0.6	1.9	1.7	1.5	ns
		XC4062XLA	0.6	2.0	1.8	1.6	ns
		XC4085XLA	0.6	2.3	2.0	1.8	ns
Preliminary							

Note: Values in **bold face** are preliminary, all other values are advance.

Delay Via Global Early BUFGEs 1, 2, 5, 6 to IOB Clock

Description	Symbol	Device	Speed Grade				Units
			All	-09	-08	-07	
			Min	Max	Max	Max	
Delay from pad through Global Early (GE) clock buffer to any IOB clock input for BUFGEs 1, 2, 5, and 6.	T _{GE}	XC4013XLA	0.2	1.7	1.5	1.3	ns
		XC4020XLA	0.2	1.9	1.7	1.5	ns
		XC4028XLA	0.2	2.1	1.9	1.7	ns
		XC4036XLA	0.3	2.4	2.2	1.9	ns
		XC4044XLA	0.3	2.7	2.4	2.2	ns
		XC4052XLA	0.3	3.0	2.7	2.4	ns
		XC4062XLA	0.3	3.3	3.0	2.7	ns
		XC4085XLA	0.3	3.7	3.3	3.0	ns
Preliminary							

Delay Via Global Early BUFGEs 3, 4, 7, 8 to IOB Clock

Description	Symbol	Device	Speed Grade				Units
			All	-09	-08	-07	
			Min	Max	Max	Max	
Delay from pad through Global Early (GE) clock buffer to any IOB clock input for BUFGEs 3, 4, 7, and 8.	T _{GE}	XC4013XLA	0.5	2.5	2.2	1.9	ns
		XC4020XLA	0.6	2.7	2.4	2.1	ns
		XC4028XLA	0.6	2.9	2.5	2.3	ns
		XC4036XLA	0.7	3.1	2.7	2.4	ns
		XC4044XLA	0.8	3.3	2.9	2.6	ns
		XC4052XLA	0.8	3.6	3.1	2.8	ns
		XC4062XLA	0.9	3.8	3.4	3.0	ns
		XC4085XLA	1.0	4.3	3.8	3.4	ns
Preliminary							

XC4000XLA CLB Characteristics

Testing of switching parameters is modeled after testing methods specified by MIL-M-38510/605. All devices are 100% functionally tested. Internal timing parameters are derived from measuring internal test patterns. Listed below are representative values. For more specific, more precise, and worst-case guaranteed data, use the values reported by the static timing analyzer (TRCE in the Xilinx Development System) and back-annotated to the simulation net list. All timing parameters assume worst-case operating conditions (supply voltage and junction temperature). Values apply to all XC4000XLA devices and expressed in nanoseconds unless otherwise noted

CLB Switching Characteristic Guidelines

Description	Speed Grade Symbol	-09		-08		-07		Units
		Min	Max	Min	Max	Min	Max	
Combinatorial Delays								
F/G inputs to X/Y outputs	T _{ILO}		1.1		1.0		0.9	ns
F/G inputs via H' to X/Y outputs	T _{IHO}		1.9		1.7		1.5	ns
F/G inputs via transparent latch to Q outputs	T _{I TO}		2.0		1.8		1.6	ns
C inputs via SR/H0 via H to X/Y outputs	T _{HH00}		1.7		1.6		1.4	ns
C inputs via H1 via H to X/Y outputs	T _{HH10}		1.6		1.4		1.3	ns
C inputs via DIN/H2 via H to X/Y outputs	T _{HH20}		1.7		1.6		1.4	ns
C inputs via EC, DIN/H2 to YQ, XQ output (bypass)	T _{CBYP}		1.1		1.0		0.9	ns
CLB Fast Carry Logic								
Operand inputs (F1, F2, G1, G4) to C _{OUT}	T _{OPCY}		1.0		0.9		0.8	ns
Add/Subtract input (F3) to C _{OUT}	T _{ASCY}		1.2		1.1		1.0	ns
Initialization inputs (F1, F3) to C _{OUT}	T _{INCY}		0.8		0.7		0.6	ns
C _{IN} through function generators to X/Y outputs	T _{SUM}		1.7		1.5		1.3	ns
C _{IN} to C _{OUT} , bypass function generators	T _{BYP}		0.1		0.1		0.1	ns
Carry Net Delay, C _{OUT} to C _{IN}	T _{NET}		0.17		0.15		0.13	ns
Sequential Delays								
Clock K to Flip-Flop outputs Q	T _{CKO}		1.5		1.3		1.2	ns
Clock K to Latch outputs Q	T _{CKLO}		1.5		1.3		1.2	ns
Setup Time before Clock K								
F/G inputs	T _{ICK}	0.7		0.7		0.6		ns
F/G inputs via H	T _{IHCK}	1.4		1.3		1.2		ns
C inputs via H0 through H	T _{HH0CK}	1.3		1.2		1.1		ns
C inputs via H1 through H	T _{HH1CK}	1.2		1.1		1.0		ns
C inputs via H2 through H	T _{HH2CK}	1.3		1.2		1.1		ns
C inputs via DIN	T _{DICK}	0.6		0.6		0.5		ns
C inputs via EC	T _{ECCK}	0.7		0.6		0.5		ns
C inputs via S/R, going Low (inactive)	T _{RCK}	0.5		0.4		0.4		ns
C _{IN} input via F/G	T _{CCK}	1.2		1.1		1.0		ns
C _{IN} input via F/G and H	T _{CHCK}	2.0		1.7		1.6		ns
Hold Time after Clock K								
All Hold Times		0.0		0.0		0.0		ns
Clock								
Clock High time	T _{CH}	2.2		1.9		1.7		ns
Clock Low time	T _{CL}	2.2		1.9		1.7		ns
Set/Reset Direct								
Width (High)	T _{RPW}	2.3		2.3		2.3		ns
Delay from C inputs via S/R, going High to Q	T _{RIO}		2.5		2.2		2.0	ns
Global Set/Reset								
Minimum GSR Pulse Width	T _{MRW}		12.8		11.4		10.2	ns
Delay from GSR input to any Q	T _{MRQ}	See page 184 for TRRI values per device.						
Toggle Frequency (MHz) (for export control)	F _{TOG}		227		263		294	MHz
Preliminary								

CLB Single Port RAM Synchronous (Edge-Triggered) Write Operation Guidelines

Testing of switching parameters is modeled after testing methods specified by MIL-M-38510/605. All devices are 100% functionally tested. Internal timing parameters are derived from measuring internal test patterns. Listed below are representative values. For more specific, more precise, and worst-case guaranteed data, use the values reported by the static timing analyzer (TRCE in the Xilinx Development System) and back-annotated to the simulation net list. All timing parameters assume worst-case operating conditions (supply voltage and junction temperature). Values apply to all XC4000XLA devices and are expressed in nanoseconds unless otherwise noted.

Single Port RAM	Speed Grade		-09		-08		-07		Units
	Size	Symbol	Min	Max	Min	Max	Min	Max	
Write Operation									
Address write cycle time (clock K period)	16x2	T_{WCS}	6.7		5.9		5.3		ns
	32x1	T_{WCTS}	6.7		5.9		5.3		ns
Clock K pulse width (active edge)	16x2	T_{WPS}	3.4		3.0		2.7		ns
	32x1	T_{WPTS}	3.4		3.0		2.7		ns
Address setup time before clock K	16x2	T_{ASS}	1.5		1.3		1.2		ns
	32x1	T_{ASTS}	1.5		1.3		1.2		ns
Address hold time after clock K	16x2	T_{AHS}	0.0		0.0		0.0		ns
	32x1	T_{AHTS}	0.0		0.0		0.0		ns
DIN setup time before clock K	16x2	T_{DSS}	1.5		1.3		1.2		ns
	32x1	T_{DSTS}	1.8		1.6		1.5		ns
DIN hold time after clock K	16x2	T_{DHS}	0.0		0.0		0.0		ns
	32x1	T_{DHTS}	0.0		0.0		0.0		ns
WE setup time before clock K	16x2	T_{WSS}	1.4		1.3		1.1		ns
	32x1	T_{WSTS}	1.3		1.2		1.1		ns
WE hold time after clock K	16x2	T_{WHS}	0.0		0.0		0.0		ns
	32x1	T_{WHTS}	0.0		0.0		0.0		ns
Data valid after clock K	16x2	T_{WOS}		5.0		4.4		4.2	ns
	32x1	T_{WOTS}		5.8		5.2		4.7	ns
Read Operation									
Address read cycle time	16x2	T_{RC}	2.6		2.6		2.6		ns
	32x1	T_{RCT}	3.8		3.8		3.8		ns
Data Valid after address change (no Write Enable)	16x2	T_{ILO}		1.1		1.0		0.9	ns
	32x1	T_{IHO}		1.9		1.7		1.5	ns
Address setup time before clock K	16x2	T_{ICK}	0.7		0.7		0.6		ns
	32x1	T_{IHCK}	1.4		1.3		1.2		ns
Preliminary									

CLB Dual Port RAM Synchronous (Edge-Triggered) Write Operation Guidelines

Dual Port RAM	Speed Grade		-09		-08		-07		Units
	Size	Symbol	Min	Max	Min	Max	Min	Max	
Address write cycle time (clock K period)	16x1	T_{WCDS}	6.7		5.9		5.3		ns
Clock K pulse width (active edge)	16x1	T_{WPDS}	3.4		3.0		2.7		ns
Address setup time before clock K	16x1	T_{ASDS}	1.5		1.3		1.2		ns
Address hold time after clock K	16x1	T_{AHDS}	0.0		0.0		0.0		ns
DIN setup time before clock K	16x1	T_{DSDS}	1.7		1.6		1.4		ns
DIN hold time after clock K	16x1	T_{DHDS}	0.0		0.0		0.0		ns
WE setup time before clock K	16x1	T_{WSDS}	1.4		1.3		1.1		ns
WE hold time after clock K	16x1	T_{WHDS}	0.0		0.0		0.0		ns
Data valid after clock K	16x1	T_{WODS}		5.7		5.1		4.6	ns

Preliminary

Note: Timing for 16x1 option is identical to 16x2 RAM.

CLB RAM Synchronous (Edge-Triggered) Write Timing Waveforms

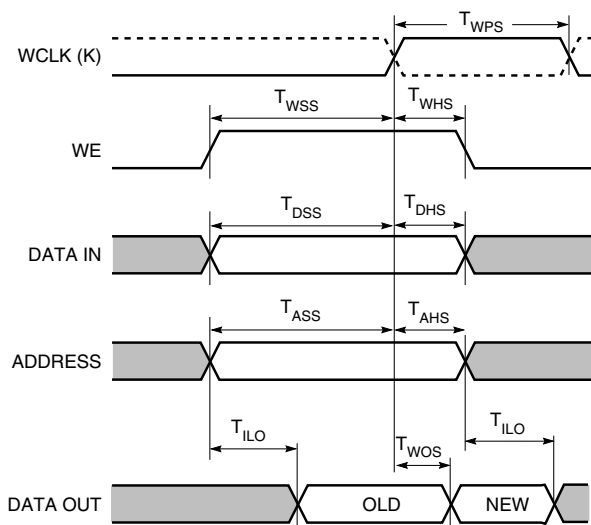

Single Port RAM

X6461

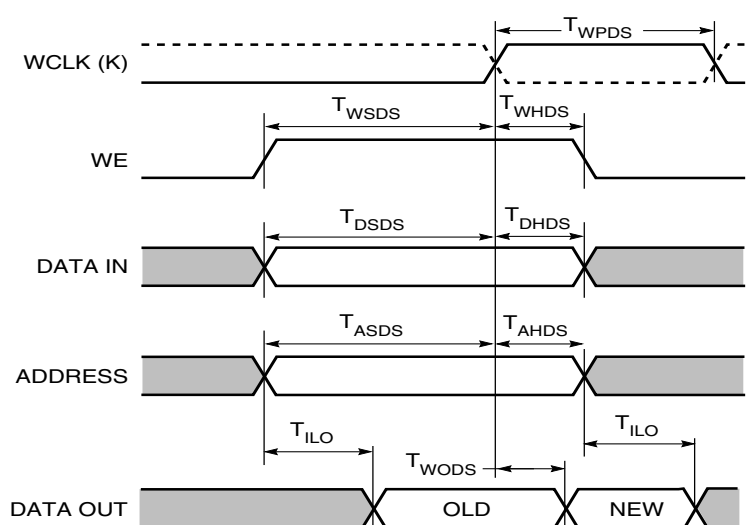

Dual Port RAM

X6474

XC4000XLA Pin-to-Pin Output Parameter Guidelines

Testing of switching parameters is modeled after testing methods specified by MIL-M-38510/605. All devices are 100% functionally tested. Pin-to-pin timing parameters are derived from measuring external and internal test patterns and are guaranteed over worst-case operating conditions (supply voltage and junction temperature). Listed below are representative values for typical pin locations and normal clock loading. For more specific, more precise, and worst-case guaranteed data, reflecting the actual routing structure, use the values provided by the static timing analyzer (TRCE in the Xilinx Development System) and back-annotated to the simulation net list. These path delays, provided as a guideline, have been extracted from the static timing analyzer report. Values are expressed in nanoseconds unless otherwise noted.

Global Clock Input to Output Delay

Description	Symbol	Device	Speed Grade				Units
			All	-09	-08	-07	
			Min	Max	Max	Max	
Global Low Skew (GLS) Clock Input to Output Delay using Output Flip-Flop	T _{ICKOF}	XC4013XLA	1.2	5.6	5.0	4.5	ns
		XC4020XLA	1.3	5.8	5.2	4.7	ns
		XC4028XLA	1.4	6.1	5.5	4.9	ns
		XC4036XLA	1.4	6.4	5.7	5.1	ns
		XC4044XLA	1.5	6.8	6.0	5.4	ns
		XC4052XLA	1.6	7.1	6.3	5.7	ns
		XC4062XLA	1.6	7.4	6.6	5.9	ns
		XC4085XLA	1.6	8.2	7.3	6.5	ns
For output SLOW option add	T _{SLOW}	All Devices	0.5	1.7	1.6	1.4	ns
Preliminary							

Notes: Listed above are representative values where one global clock input drives one vertical clock line in each accessible column, and where all accessible IOB and CLB flip-flops are clocked by the global clock net.

Output timing is measured at ~50% V_{CC} threshold with 50 pF external capacitive load. For different loads, see [Figure 1](#).

FastCLK Input to Output Delay for BUFNW, BUFSW, BUFNE, & BUFSE

Description	Symbol	Device	Speed Grade				Units
			All	-09	-08	-07	
			Min	Max	Max	Max	
FastCLK Input to Output Delay using Output Flip-Flop for FastCLK buffers BUFNW, BUFSW, BUFNE, and BUFSE.	T _{ICKFOF}	XC4013XLA	1.0	4.6	4.1	3.7	ns
		XC4020XLA	1.0	4.7	4.2	3.7	ns
		XC4028XLA	1.0	4.8	4.3	3.8	ns
		XC4036XLA	1.1	4.9	4.4	3.9	ns
		XC4044XLA	1.1	5.0	4.4	4.0	ns
		XC4052XLA	1.1	5.1	4.5	4.1	ns
		XC4062XLA	1.1	5.2	4.6	4.1	ns
		XC4085XLA	1.1	5.4	4.8	4.3	ns
Preliminary							

Notes: Listed above are representative values where one global clock input drives one vertical clock line in each accessible column, and where all accessible IOB and CLB flip-flops are clocked by the global clock net.

Output timing is measured at ~50% V_{CC} threshold with 50 pF external capacitive load. For different loads, see [Figure 1](#).

Global Early Clock Input to Output Delay for BUFGE #s 1, 2, 5, and 6

Description	Symbol	Device	Speed Grade				Units
			All	-09	-08	-07	
			Min	Max	Max	Max	
Global Clock Signal Input to Output Delay using Global Early (GE) clock buffer to clock Output Flip-Flop for BUFGE #s 1, 2, 5, & 6.	T _{ICKEOF}	XC4013XLA	0.8	4.9	4.4	3.9	ns
		XC4020XLA	0.8	5.1	4.6	4.1	ns
		XC4028XLA	0.8	5.3	4.8	4.3	ns
		XC4036XLA	0.8	5.6	5.1	4.5	ns
		XC4044XLA	0.9	5.9	5.3	4.8	ns
		XC4052XLA	0.9	6.2	5.6	5.0	ns
		XC4062XLA	0.9	6.5	5.9	5.3	ns
		XC4085XLA	0.9	6.9	6.2	5.6	ns
Preliminary							

Notes: Listed above are representative values where one global clock input drives one vertical clock line in each accessible column, and where all accessible IOB and CLB flip-flops are clocked by the global clock net. Output timing is measured at ~50% V_{CC} threshold with 50 pF external capacitive load. For different loads, see [Figure 1](#).

Global Early Clock Input to Output Delay for BUFGE #s 3, 4, 7, and 8

Description	Symbol	Device	Speed Grade				Units
			All	-09	-08	-07	
			Min	Max	Max	Max	
Global Clock Signal Input to Output Delay using Global Early (GE) clock buffer to clock Output Flip-Flop for BUFGE #s 3, 4, 7, & 8.	T _{ICKEOF}	XC4013XLA	1.1	5.7	5.1	4.5	ns
		XC4020XLA	1.1	5.9	5.3	4.7	ns
		XC4028XLA	1.2	6.1	5.4	4.9	ns
		XC4036XLA	1.3	6.3	5.6	5.0	ns
		XC4044XLA	1.3	6.5	5.8	5.2	ns
		XC4052XLA	1.4	6.8	6.0	5.4	ns
		XC4062XLA	1.5	7.0	6.3	5.6	ns
		XC4085XLA	1.6	7.5	6.7	6.0	ns
Preliminary							

Notes: Listed above are representative values where one global clock input drives one vertical clock line in each accessible column, and where all accessible IOB and CLB flip-flops are clocked by the global clock net. Output timing is measured at ~50% V_{CC} threshold with 50 pF external capacitive load. For different loads, see [Figure 1](#).

Capacitive Load Factor

[Figure 1](#) shows the relationship between I/O output delay and load capacitance. It allows a user to adjust the specified output delay if the load capacitance is different than 50 pF. For example, if the actual load capacitance is 120 pF, add 2.5 ns to the specified delay. If the load capacitance is 20 pF, subtract 0.8 ns from the specified output delay.

[Figure 1](#) is usable over the specified operating conditions of voltage and temperature and is independent of the output slew rate control.

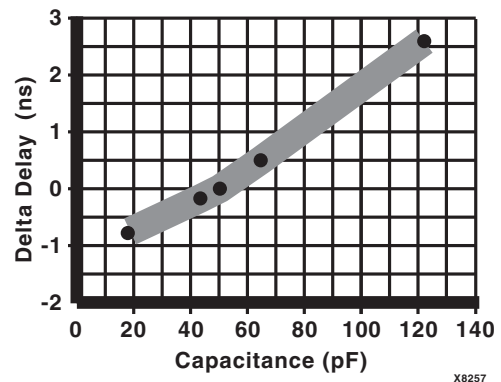

Figure 1: Delay Factor at Various Capacitive Loads

XC4000XLA Pin-to-Pin Input Parameter Guidelines

Testing of switching parameters is modeled after testing methods specified by MIL-M-38510/605. All devices are 100% functionally tested. Pin-to-pin timing parameters are derived from measuring external and internal test patterns and are guaranteed over worst-case operating conditions (supply voltage and junction temperature). Listed below are representative values for typical pin locations and normal clock loading. For more specific, more precise, and worst-case guaranteed data, reflecting the actual routing structure, use the values provided by the static timing analyzer (TRCE in the Xilinx Development System) and back-annotated to the simulation net list. These path delays, provided as a guideline, have been extracted from the static timing analyzer report. Values are expressed in nanoseconds unless otherwise noted.

Global Low Skew Clock, Set-Up and Hold

			Speed Grade			Units
Description	Symbol	Device	-09 Min	-08 Min	-07 Min	
Input Setup and Hold Time Relative to Global Clock Input Signal						
No Delay Global Low Skew Clock and IFF	T_{PSN}/T_{PHN}	XC4013XLA	1.0 / 3.0	0.8 / 2.6	0.2 / 2.5	ns
		XC4020XLA	0.9 / 3.2	0.7 / 2.9	0.1 / 2.7	ns
		XC4028XLA	0.8 / 3.8	0.6 / 3.3	0.0 / 3.0	ns
		XC4036XLA	0.6 / 4.0	0.4 / 3.5	0.0 / 3.3	ns
		XC4044XLA	0.4 / 4.4	0.2 / 3.9	0.0 / 3.6	ns
		XC4052XLA	0.3 / 4.6	0.2 / 4.1	0.0 / 3.9	ns
		XC4062XLA	0.2 / 5.0	0.1 / 4.5	0.0 / 4.2	ns
		XC4085XLA	0.0 / 5.4	0.0 / 4.8	0.0 / 4.5	ns
Partial Delay Global Low Skew Clock and IFF	T_{PSP}/T_{PHP}	XC4013XLA	4.4 / 0.5	4.1 / 0.3	3.7 / 0.0	ns
		XC4020XLA	4.5 / 0.6	4.1 / 0.3	3.7 / 0.0	ns
		XC4028XLA	4.6 / 0.7	4.2 / 0.4	3.7 / 0.0	ns
		XC4036XLA	4.6 / 0.8	4.2 / 0.4	3.7 / 0.0	ns
		XC4044XLA	4.7 / 0.9	4.3 / 0.5	3.8 / 0.0	ns
		XC4052XLA	4.8 / 1.0	4.3 / 0.6	3.8 / 0.2	ns
		XC4062XLA	5.0 / 1.0	4.4 / 0.7	3.8 / 0.4	ns
		XC4085XLA	5.5 / 1.2	4.7 / 0.9	3.8 / 0.5	ns
Full Delay Global Low Skew Clock and IFF	T_{PSD}/T_{PHD}	XC4013XLA	4.4 / 0.0	4.1 / 0.0	3.7 / 0.0	ns
		XC4020XLA	4.6 / 0.0	4.2 / 0.0	3.8 / 0.0	ns
		XC4028XLA	4.8 / 0.0	4.4 / 0.0	3.9 / 0.0	ns
		XC4036XLA	4.9 / 0.0	4.5 / 0.0	4.0 / 0.0	ns
		XC4044XLA	5.0 / 0.0	4.6 / 0.0	4.1 / 0.0	ns
		XC4052XLA	5.2 / 0.0	4.7 / 0.0	4.2 / 0.0	ns
		XC4062XLA	5.5 / 0.0	4.9 / 0.0	4.3 / 0.0	ns
		XC4085XLA	6.0 / 0.0	5.2 / 0.0	4.4 / 0.0	ns

IFF = Input Flip-Flop or Latch

Preliminary

Note: Setup time is measured relative to the Global Clock input signal with the fastest route and the lightest load. Hold time is measured relative to the Global Clock input signal using the furthest distance and a reference load of one clock pin per two IOBs. Use the static timing analyzer (TRCE) to determine the setup and hold times under given design conditions.

FastCLK Input Set-Up and Hold for BUFNW, BUFSW, BUFNE, & BUFSE

		Speed Grade	-09	-08	-07	Units
Description	Symbol	Device	Min	Min	Min	
Input Setup and Hold Time Relative to FastCLK Input Signal						
No Delay FastCLK and IFF	T_{PSFN}/T_{PHFN}	XC4013XLA	0.0 / 3.2	0.0 / 2.9	0.0 / 2.6	ns
		XC4020XLA	0.0 / 3.3	0.0 / 3.0	0.0 / 2.7	ns
		XC4028XLA	0.0 / 3.4	0.0 / 3.1	0.0 / 2.8	ns
		XC4036XLA	0.0 / 3.5	0.0 / 3.2	0.0 / 2.9	ns
		XC4044XLA	0.0 / 3.6	0.0 / 3.3	0.0 / 3.0	ns
		XC4052XLA	0.0 / 3.7	0.0 / 3.4	0.0 / 3.1	ns
		XC4062XLA	0.0 / 3.8	0.0 / 3.5	0.0 / 3.2	ns
		XC4085XLA	0.0 / 3.9	0.0 / 3.6	0.0 / 3.3	ns
Partial Delay FastCLK and IFF	T_{PSFP}/T_{PHFP}	XC4013XLA	3.5 / 0.6	3.2 / 0.3	2.9 / 0.0	ns
		XC4020XLA	3.7 / 0.4	3.4 / 0.2	3.1 / 0.0	ns
		XC4028XLA	3.9 / 0.2	3.6 / 0.1	3.3 / 0.0	ns
		XC4036XLA	4.1 / 0.0	3.8 / 0.0	3.5 / 0.0	ns
		XC4044XLA	4.3 / 0.0	4.0 / 0.0	3.7 / 0.0	ns
		XC4052XLA	4.5 / 0.0	4.2 / 0.0	3.9 / 0.0	ns
		XC4062XLA	4.7 / 0.0	4.4 / 0.0	4.1 / 0.0	ns
		XC4085XLA	5.1 / 0.0	4.8 / 0.0	4.5 / 0.0	ns
Full Delay FastCLK and IFF	T_{PSFD}/T_{PHFD}	XC4013XLA	3.5 / 0.6	3.2 / 0.3	2.9 / 0.0	ns
		XC4020XLA	3.8 / 0.4	3.5 / 0.2	3.2 / 0.0	ns
		XC4028XLA	4.0 / 0.2	3.7 / 0.1	3.4 / 0.0	ns
		XC4036XLA	4.3 / 0.0	4.0 / 0.0	3.7 / 0.0	ns
		XC4044XLA	4.6 / 0.0	4.3 / 0.0	4.0 / 0.0	ns
		XC4052XLA	4.9 / 0.0	4.6 / 0.0	4.3 / 0.0	ns
		XC4062XLA	5.3 / 0.0	5.0 / 0.0	4.7 / 0.0	ns
		XC4085XLA	6.1 / 0.0	5.8 / 0.0	5.5 / 0.0	ns
Preliminary						

IFF = Input Flip-Flop or Latch

Note: Setup time is measured with the fastest route and the lightest load. Hold time is measured using the furthest distance and a reference load of one clock pin per two IOBs. Use the static timing analyzer (TRCE) to determine the setup and hold times under given design conditions.

IBUFGE #s 1, 2, 5, and 6 Global Early Clock, Set-up and Hold for IFF and FCL

Testing of switching parameters is modeled after testing methods specified by MIL-M-38510/605. All devices are 100% functionally tested. Pin-to-pin timing parameters are derived from measuring external and internal test patterns and are guaranteed over worst-case operating conditions (supply voltage and junction temperature). Listed below are representative values for typical pin locations and normal clock loading. For more specific, more precise, and worst-case guaranteed data, reflecting the actual routing structure, use the values provided by the static timing analyzer (TRCE in the Xilinx Development System) and back-annotated to the simulation net list. These path delays, provided as a guideline, have been extracted from the static timing analyzer report. Values are expressed in nanoseconds unless otherwise noted.

			Speed Grade			Units
Description	Symbol	Device	-09 Min	-08 Min	-07 Min	
Input Setup and Hold Time Relative to Global Clock Input Signal						
No Delay Global Early Clock and IFF Global Early Clock and FCL	T_{PSEN}/T_{PHEN} T_{PFSEN}/T_{PFHEN}	XC4013XLA	1.0 / 3.2	0.8 / 2.6	0.5 / 1.8	ns
		XC4020XLA	1.0 / 3.4	0.8 / 2.8	0.5 / 2.0	ns
		XC4028XLA	1.0 / 3.5	0.8 / 3.0	0.5 / 2.2	ns
		XC4036XLA	1.0 / 3.6	0.8 / 3.1	0.5 / 2.4	ns
		XC4044XLA	1.0 / 3.8	0.8 / 3.3	0.5 / 2.6	ns
		XC4052XLA	1.0 / 4.0	0.8 / 3.5	0.5 / 2.8	ns
		XC4062XLA	1.0 / 4.2	0.8 / 3.7	0.5 / 3.0	ns
		XC4085XLA	1.0 / 4.6	0.8 / 4.0	0.5 / 3.2	ns
Partial Delay Global Early Clock and IFF Global Early Clock and FCL	T_{PSEP}/T_{PHEP} T_{PFSEP}/T_{PFHEP}	XC4013XLA	4.6 / 0.0	4.2 / 0.0	3.9 / 0.0	ns
		XC4020XLA	4.8 / 0.1	4.4 / 0.1	4.1 / 0.0	ns
		XC4028XLA	4.9 / 0.1	4.6 / 0.1	4.4 / 0.0	ns
		XC4036XLA	5.0 / 0.2	4.7 / 0.1	4.5 / 0.0	ns
		XC4044XLA	5.5 / 0.3	5.1 / 0.2	4.8 / 0.0	ns
		XC4052XLA	5.8 / 0.3	5.3 / 0.2	5.0 / 0.0	ns
		XC4062XLA	6.2 / 0.4	5.6 / 0.2	5.2 / 0.0	ns
		XC4085XLA	6.5 / 0.5	5.9 / 0.3	5.4 / 0.0	ns
Full Delay Global Early Clock and IFF	T_{PSED}/T_{PHED}	XC4013XLA	4.6 / 0.0	4.2 / 0.0	3.9 / 0.0	ns
		XC4020XLA	4.9 / 0.0	4.5 / 0.0	4.1 / 0.0	ns
		XC4028XLA	5.1 / 0.0	4.7 / 0.0	4.4 / 0.0	ns
		XC4036XLA	5.3 / 0.0	4.9 / 0.0	4.5 / 0.0	ns
		XC4044XLA	5.8 / 0.0	5.3 / 0.0	5.0 / 0.0	ns
		XC4052XLA	6.2 / 0.0	5.7 / 0.0	5.3 / 0.0	ns
		XC4062XLA	6.7 / 0.0	6.1 / 0.0	5.6 / 0.0	ns
		XC4085XLA	7.0 / 0.0	6.4 / 0.0	6.0 / 0.0	ns

IFF = Input Flip-Flop or Latch, FCL = Fast Capture Latch

Preliminary

Note: Setup time is measured relative to the Global Clock input signal with the fastest route and the lightest load. Hold time is measured relative to the Global Clock input signal using the furthest distance and a reference load of one clock pin per two IOBs. Use the static timing analyzer (TRCE) to determine the setup and hold times under given design conditions.

BUFGE #s 3, 4, 7, and 8 Global Early Clock, Set-up and Hold for IFF and FCL

		Speed Grade	-09	-08	-07	Units
Description	Symbol	Device	Min	Min	Min	
Input Setup and Hold Time Relative to Global Clock Input Signal						
No Delay Global Early Clock and IFF Global Early Clock and FCL	T_{PSEN}/T_{PHEN} T_{PFSEN}/T_{PFHEN}	XC4013XLA	0.8 / 3.2	0.6 / 2.6	0.4 / 2.0	ns
		XC4020XLA	0.8 / 3.4	0.6 / 2.8	0.4 / 2.2	ns
		XC4028XLA	0.8 / 3.5	0.6 / 3.0	0.4 / 2.4	ns
		XC4036XLA	0.8 / 3.6	0.6 / 3.1	0.4 / 2.6	ns
		XC4044XLA	0.8 / 3.8	0.6 / 3.3	0.4 / 2.8	ns
		XC4052XLA	0.8 / 4.0	0.6 / 3.5	0.4 / 3.0	ns
		XC4062XLA	0.8 / 4.2	0.6 / 3.7	0.4 / 3.2	ns
		XC4085XLA	0.8 / 4.6	0.6 / 4.0	0.4 / 3.4	ns
Partial Delay Global Early Clock and IFF Global Early Clock and FCL	T_{PSEP}/T_{PHEP} T_{PFSEP}/T_{PFHEP}	XC4013XLA	4.4 / 0.0	4.0 / 0.0	3.6 / 0.0	ns
		XC4020XLA	4.6 / 0.1	4.2 / 0.1	3.8 / 0.0	ns
		XC4028XLA	4.7 / 0.1	4.4 / 0.1	4.1 / 0.0	ns
		XC4036XLA	4.8 / 0.2	4.5 / 0.2	4.2 / 0.0	ns
		XC4044XLA	5.2 / 0.3	4.8 / 0.3	4.4 / 0.0	ns
		XC4052XLA	5.6 / 0.3	5.1 / 0.3	4.6 / 0.0	ns
		XC4062XLA	6.0 / 0.4	5.4 / 0.4	4.8 / 0.0	ns
		XC4085XLA	6.3 / 0.5	5.7 / 0.5	5.0 / 0.0	ns
Full Delay Global Early Clock and IFF	T_{PSED}/T_{PHED}	XC4013XLA	4.4 / 0.0	4.0 / 0.0	3.6 / 0.0	ns
		XC4020XLA	4.7 / 0.0	4.3 / 0.0	3.8 / 0.0	ns
		XC4028XLA	4.9 / 0.0	4.5 / 0.0	4.1 / 0.0	ns
		XC4036XLA	5.1 / 0.0	4.7 / 0.0	4.2 / 0.0	ns
		XC4044XLA	5.6 / 0.0	5.1 / 0.0	4.6 / 0.0	ns
		XC4052XLA	6.0 / 0.0	5.5 / 0.0	4.9 / 0.0	ns
		XC4062XLA	6.5 / 0.0	5.9 / 0.0	5.2 / 0.0	ns
		XC4085XLA	6.8 / 0.0	6.2 / 0.0	5.6 / 0.0	ns
			Preliminary			

IFF = Input Flip-Flop or Latch, FCL = Fast Capture Latch

Note: Setup time is measured relative to the Global Clock input signal with the fastest route and the lightest load. Hold time is measured relative to the Global Clock input signal using the furthest distance and a reference load of one clock pin per two IOBs. Use the static timing analyzer (TRCE) to determine the setup and hold times under given design conditions.

IOB Input Switching Characteristic Guidelines

Testing of switching parameters is modeled after testing methods specified by MIL-M-38510/605. All devices are 100% functionally tested. Internal timing parameters are derived from measuring internal test patterns. Listed below are representative values. For more specific, more precise, and worst-case guaranteed data, use the values reported by the static timing analyzer (TRCE in the Xilinx Development System) and back-annotated to the simulation net list. These path delays, provided as a guideline, have been extracted from the static timing analyzer report. All timing parameters assume worst-case operating conditions (supply voltage and junction temperature).

IOB Input Delay Guidelines

Description	Symbol	Speed Grade Device	-09		-08		-07		Units
			Min	Max	Min	Max	Min	Max	
Clocks									
Clock Enable (EC) to Clock (IK)	T _{ECIK}	All devices	0.0		0.0		0.0		ns
Delay from FCL enable (OK) active edge to IFF clock (IK) active edge	T _{OKIK}	All Devices	1.4		1.3		1.2		ns
Setup Times									
Pad to Clock (IK), no delay	T _{PICK}	All Devices	1.2		1.0		0.9		ns
Pad to Clock (IK), via transparent Fast Capture Latch, no delay	T _{PICKF}	All Devices	1.6		1.4		1.3		ns
Pad to Fast Capture Latch Enable (OK), no delay	T _{POCK}	All Devices	0.8		0.7		0.6		ns
Hold Times									
All Hold Times		All Devices	0.0		0.0		0.0		ns
Global Set/Reset									
Minimum GSR Pulse Width	T _{MRW}	All devices	12.8		11.4		10.2		ns
Global Set/Reset									
Delay from GSR input to any Q	T _{RR1*}	XC4013XLA		11.4		10.2		9.1	ns
		XC4020XLA		13.3		11.9		10.6	ns
		XC4028XLA		14.3		12.8		11.4	ns
		XC4036XLA		16.2		14.5		12.9	ns
		XC4044XLA		18.1		16.2		14.4	ns
		XC4052XLA		19.5		17.4		15.6	ns
		XC4062XLA		20.9		18.7		16.7	ns
		XC4085XLA		24.7		22.1		19.7	ns
Propagation Delays									
Pad to I1, I2	T _{PID}	All devices		1.0		0.9		0.8	ns
Pad to I1, I2 via transparent input latch, no delay	T _{PLI}	All devices		2.1		1.9		1.7	ns
Pad to I1, I2 via transparent FCL and input latch, no delay	T _{PFLI}	All devices		2.5		2.2		2.0	ns
Clock (IK) to I1, I2 (flip-flop)	T _{IKRI}	All devices		1.1		1.0		0.9	ns
Clock (IK) to I1, I2 (latch enable, active Low)	T _{IKLI}	All devices		1.2		1.1		1.0	ns
FCL Enable (OK) active edge to I1, I2 (via transparent standard input latch)	T _{OKLI}	All devices		2.4		2.1		1.9	ns
			Preliminary						

IFF = Input Flip-Flop or Latch, FCL = Fast Capture Latch

* Indicates Minimum Amount of Time to Assure Valid Data.

XLA IOB Output Switching Characteristic Guidelines

Testing of switching parameters is modeled after testing methods specified by MIL-M-38510/605. All devices are 100% functionally tested. Internal timing parameters are derived from measuring internal test patterns. Listed below are representative values. For more specific, more precise, and worst-case guaranteed data, use the values reported by the static timing analyzer (TRCE in the Xilinx Development System) and back-annotated to the simulation net list. These path delays, provided as a guideline, have been extracted from the static timing analyzer report. All timing parameters assume worst-case operating conditions (supply voltage and junction temperature). For Propagation Delays, slew-rate = fast unless otherwise noted. Values are expressed in nanoseconds unless otherwise noted.

			Speed Grade						Units
Description	Symbol	Device	-09		-08		-07		
			Min	Max	Min	Max	Min	Max	
Clocks									
Clock High	T_{CH}	All devices	2.2		1.9		1.7		ns
Clock Low	T_{CL}	All devices	2.2		1.9		1.7		ns
Propagation Delays									
Clock (OK) to Pad	T_{OKPOF}	All devices		3.2		2.9		2.6	ns
Output (O) to Pad	T_{OPF}	All devices		2.6		2.4		2.1	ns
3-state to Pad hi-Z (slew-rate independent)	T_{TSHZ}	All devices		2.7		2.4		2.2	ns
3-state to Pad active and valid	T_{TSONF}	All devices		2.8		2.5		2.3	ns
Clock to Pad hi-Z	T_{OKSHZ}	All devices		3.5		3.1		2.8	ns
Clock to Pad active and valid	T_{OKSONF}	All devices		3.6		3.2		2.9	ns
Output (O) to Pad via Fast Output MUX	T_{OFFPF}	All devices		3.6		3.2		2.9	ns
Select (OK) to Pad via Fast MUX	T_{OKFPF}	All devices		3.3		3.0		2.6	ns
Setup and Hold Times									
Output (O) to clock (OK) setup time	T_{OOK}	All devices	0.3		0.3		0.3		ns
Output (O) to clock (OK) hold time	T_{OKO}	All devices	0.0		0.0		0.0		ns
Clock Enable (EC) to clock (OK) setup time	T_{ECOK}	All devices	0.0		0.0		0.0		ns
Clock Enable (EC) to clock (OK) hold time	T_{OKEC}	All devices	0.0		0.0		0.0		ns
Global Set/Reset									
Minimum GSR pulse width	T_{MRW}		12.8		11.4		10.2		ns
Delay from GSR input to any Pad	T_{RPO}^*	XC4013XLA		14.4		12.8		11.5	ns
		XC4020XLA		16.3		14.5		13.0	ns
		XC4028XLA		17.3		15.4		13.8	ns
		XC4036XLA		19.1		17.1		15.3	ns
		XC4044XLA		21.0		18.8		16.8	ns
		XC4052XLA		22.5		20.1		17.9	ns
		XC4062XLA		23.9		21.3		19.0	ns
		XC4085XLA		27.7		24.7		22.1	ns
Slew Rate Adjustment									
For output SLOW option add	T_{SLOW}			1.7		1.6		1.4	ns
			Preliminary						

* Indicates Minimum Amount of Time to Assure Valid Data

Revision Control

Version	Description
01/28/1999 (1.0)	Release included in 1999 data book, section 6
02/19/1999 (1.1)	Updated Switching Characteristics Tables
05/14/1999 (1.2)	Replaced Electrical Specification pages for XLA and XV families with separate updates and added URL link on placeholder page for electrical specifications/pinouts for WebLINX users.
10/04/1999 (1.3)	Added Power-on specification.
03/01/2013 (2.0)	The products listed in this data sheet are obsolete. See XCN09002 for further information.